



Chipsmall Limited consists of a professional team with an average of over 10 year of expertise in the distribution of electronic components. Based in Hongkong, we have already established firm and mutual-benefit business relationships with customers from,Europe,America and south Asia,supplying obsolete and hard-to-find components to meet their specific needs.

With the principle of “Quality Parts,Customers Priority,Honest Operation,and Considerate Service”,our business mainly focus on the distribution of electronic components. Line cards we deal with include Microchip,ALPS,ROHM,Xilinx,Pulse,ON,Everlight and Freescale. Main products comprise IC,Modules,Potentiometer,IC Socket,Relay,Connector.Our parts cover such applications as commercial,industrial, and automotives areas.

We are looking forward to setting up business relationship with you and hope to provide you with the best service and solution. Let us make a better world for our industry!



Contact us

Tel: +86-755-8981 8866 Fax: +86-755-8427 6832

Email & Skype: info@chipsmall.com Web: www.chipsmall.com

Address: A1208, Overseas Decoration Building, #122 Zhenhua RD., Futian, Shenzhen, China



E1103 EVALUATION ASSEMBLY USER GUIDE

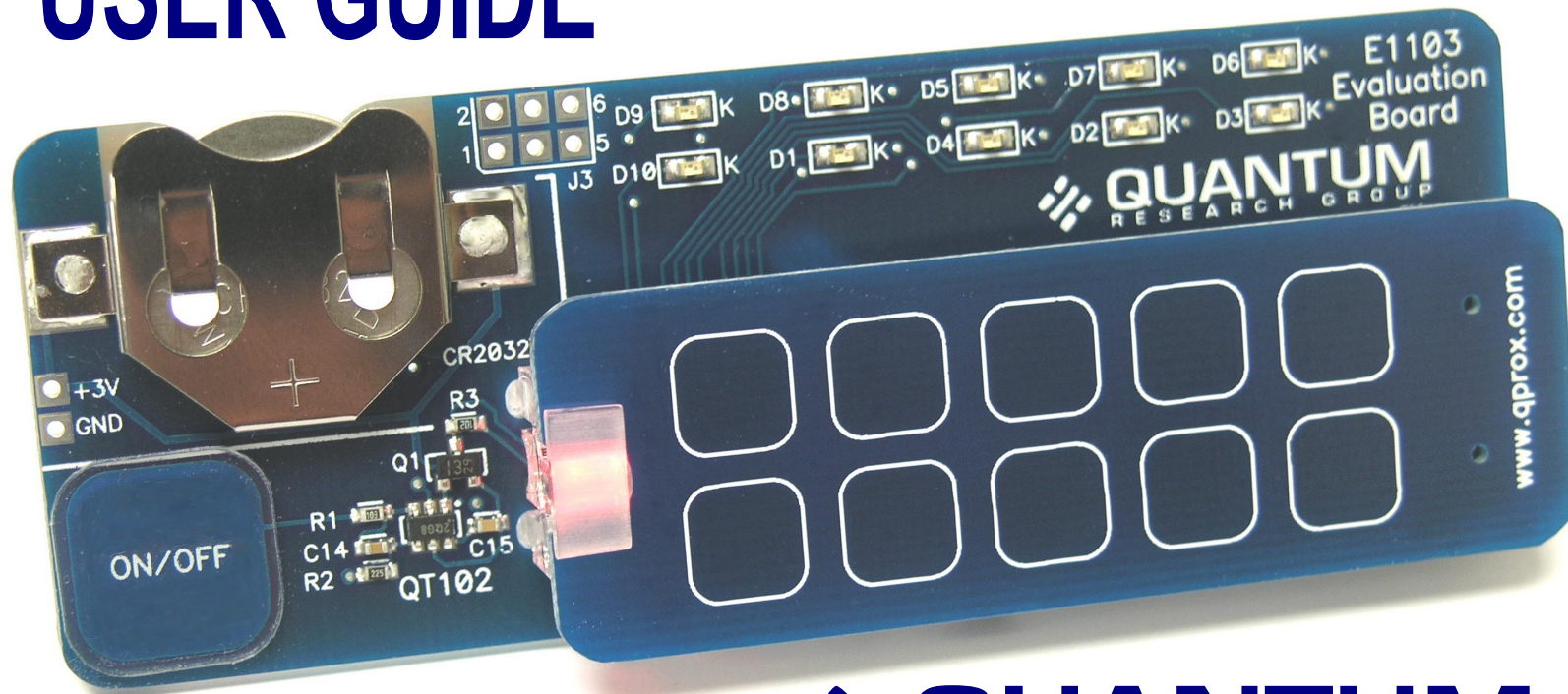

www.qprox.com

 **QUANTUM**
RESEARCH GROUP

Using the E1103:

This kit is designed for the evaluation and development of applications using the QT1103-ISG Integrated Circuit (IC). In this example the QT1103-ISG is run in Simplified mode.

Refer to the QT1103-ISG datasheet for details (see www.qprox.com/downloads).

- Ensure the E1103 Keyboard PCB is connected to J2 on the E1103 Main PCB.
- Select desired Adjacent Key Suppression (AKS) mode by moving the 2-way Jumper at J1.
- Insert the battery provided into the battery holder on the E1103 Main board.
Ensure that the battery has the correct orientation (negative (-) side to board) or the E1103 will not work.
- Touch ON/OFF - The LED (D11) under the standoff will illuminate to indicate power to QT1103-ISG.
- Touch any of the 10 key(s) on the E1103 keyboard and the corresponding LED(s) will illuminate.

Auto Power-Off: The E1103 will power off after approximately 15 minutes. (Using the auto shut-off features of the QT102-ISG fitted)

An external power supply can be used instead of a battery.

WARNING: if an external power supply is used then the battery **MUST** be removed.

Schematic:

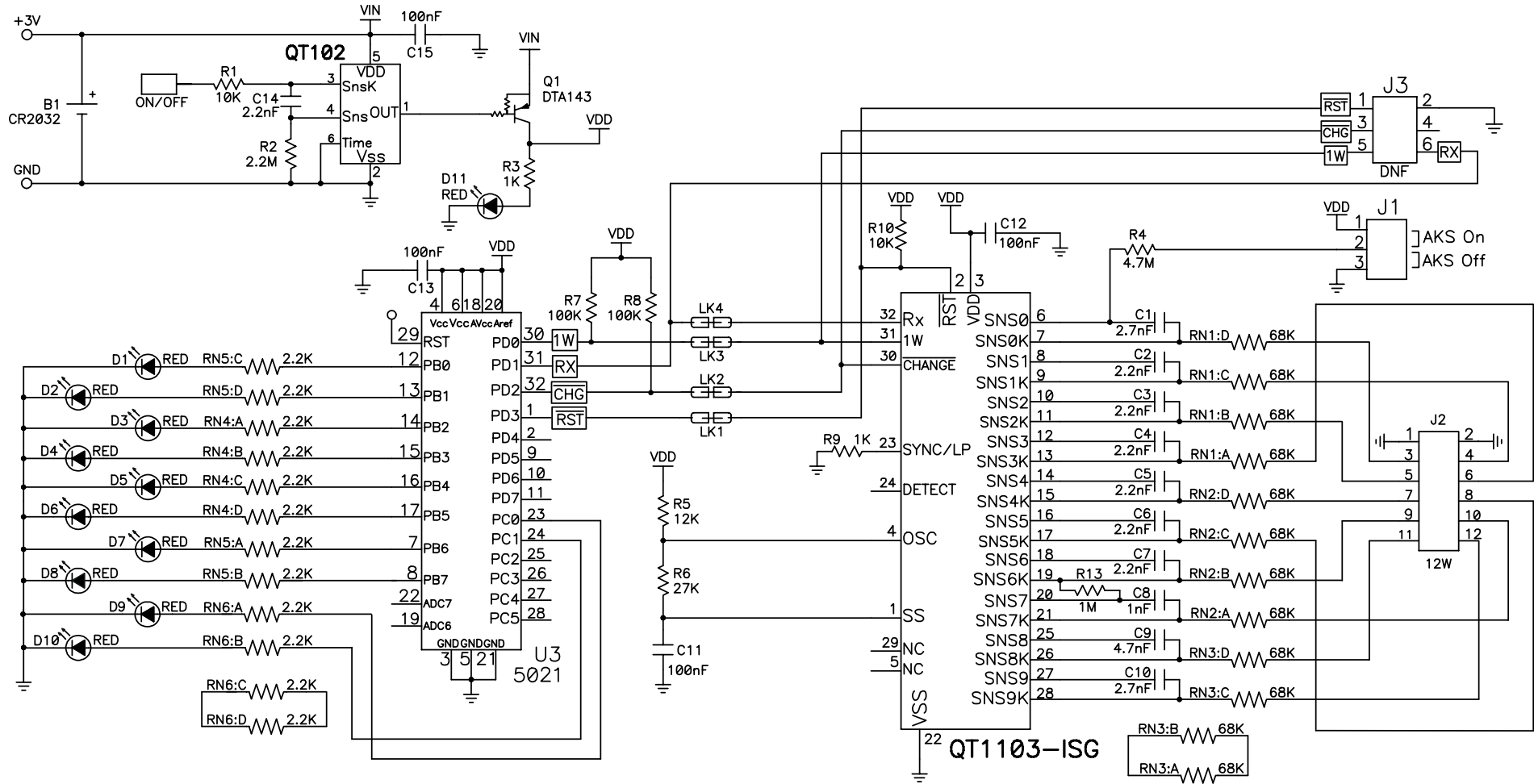

AKS Mode:

On the E1103, AKS is a global setting. Refer to the QT1103-ISG datasheet for details. The AKS mode is changed by moving the 2-way Jumper fitted to J1 as indicated.

- If set to 'On': When touching multiple keys, only the LED associated with the key with the strongest signal is lit.
- If set to 'Off': When touching multiple keys, all associated LEDs will be lit.

External Input:

The E1103 can be connected to User electrodes, using connector J2. The values of C1-C10 (sample capacitors) may require changing.

External Output:

The output of the QT1103-ISG can be accessed using J3. The tracks at LK1-4 can be cut to disconnect the QT1103-ISG from U3, which is the IC used to drive the LEDs on the E1103 Main Board.

Troubleshooting:

Problem	Potential Solution
E1103 does not work	<p>If the Power LED is off, the 15 minute timeout may have been exceeded. Touch ON/OFF to restore power.</p> <p>If using a battery, check that the negative (-) side is facing the board.</p> <p>Check/replace battery.</p> <p>If using an external power supply, check that the correct connections have been made. <i>(Ensure the battery has been removed)</i></p>
LED(s) stuck on	<p>After changing AKS Jumper position, turn power off, then on again.</p> <p>After replacing the E1103 Keyboard, turn the power off, then on again.</p>
AKS Mode unchanged after changing Jumper position	<p>Turn power off, then on again.</p>
Incorrect LED(s) light when keys touched	<p>Check J2 connector pins on E1103 Main PCB and E1103 Keyboard are correctly aligned.</p>

E1103 Kit Contents:

1x E1103 Evaluation Assembly (E1103 Main PCB and E1103 Keyboard PCB)			
1x CR2032 Battery, 3V, 235mAh			
2x sample QT1103-ISG ICs			
1x E1103 User Guide			
<i>Packed by:</i>		<i>Dated:</i>	

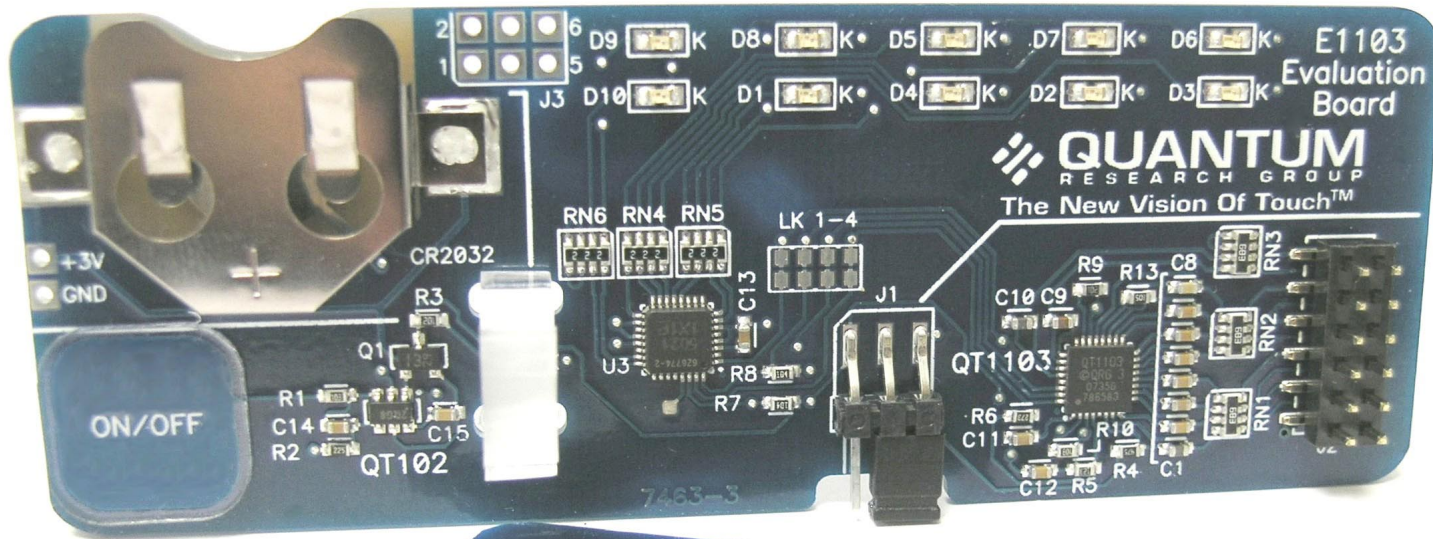

Corporate Headquarters:

1 Mitchell Point
 Ensign Way, Hamble
 Southampton SO31 4RF
 United Kingdom
 Tel:+44 (0)23 8056 5600
 Fax:+44 (0)23 8045 3939

North America:

651 Holiday Drive Bldg 5/300
 Pittsburgh, PA 15220
 USA
 Tel:412-391-7367
 Fax:412-291-1015

Developers:

John Dubery, Kevin Snoad

Copyright © 2007-2008 QRG Ltd.

All rights reserved

Patented and patents pending

www.qprox.com

REV 201.0108

