



Chipsmall Limited consists of a professional team with an average of over 10 year of expertise in the distribution of electronic components. Based in Hongkong, we have already established firm and mutual-benefit business relationships with customers from,Europe,America and south Asia,supplying obsolete and hard-to-find components to meet their specific needs.

With the principle of “Quality Parts,Customers Priority,Honest Operation,and Considerate Service”,our business mainly focus on the distribution of electronic components. Line cards we deal with include Microchip,ALPS,ROHM,Xilinx,Pulse,ON,Everlight and Freescale. Main products comprise IC,Modules,Potentiometer,IC Socket,Relay,Connector.Our parts cover such applications as commercial,industrial, and automotives areas.

We are looking forward to setting up business relationship with you and hope to provide you with the best service and solution. Let us make a better world for our industry!



Contact us

Tel: +86-755-8981 8866 Fax: +86-755-8427 6832

Email & Skype: info@chipsmall.com Web: www.chipsmall.com

Address: A1208, Overseas Decoration Building, #122 Zhenhua RD., Futian, Shenzhen, China



Product Specifications

Customer	Standard
Description	1.9" TFT EPD Panel
Model Name	E1190CS021
Date	2016/ 04/ 08
Doc. No.	1P091-00
Revision	04

Customer Approval	
Date	
The above signature represents that the product specifications, testing regulation, and warranty in the specifications are accepted	

	Design Engineering		
	Approval	Check	Design
			

4F, No. 28, Chuangye Rd., Tainan Science Park, Tainan City 74144, Taiwan (R.O.C.)

Tel: + 886-6-279-5399

Fax: + 886-6-505-5300

Copyright

Pervasive Displays Incorporated All rights reserved.

This document is the exclusive property of Pervasive Displays Inc. (PDI) and shall not be reproduced or copied or transformed to any other format without prior permission of PDI. (PDI Confidential)

本資料為龍亭新技股份有限公司專有之財產，非經許可，不得複製、翻印或轉變成其他形式使用。

龍亭新技股份有限公司 Pervasive Displays Inc.

4F, No. 28, Chuangye Rd., Tainan Science Park, Tainan City 74144, Taiwan (R.O.C.)

Tel: + 886-6-279-5399

<http://www.pervasivedisplays.com>

Table of Contents

Revision History	6
Glossary of Acronyms	7
1 General Description	8
1.1 Overview	8
1.2 Features	8
1.3 Applications	8
1.4 General Specifications	9
1.5 Mechanical Specifications	10
2 Absolute Maximum Ratings	12
2.1 Absolute Ratings of Environment	12
2.2 Reliability Test Item	13
3 Electrical Characteristics	14
3.1 Absolute Maximum Ratings of Panel	14
3.2 Recommended Operation Conditions of Panel	14
4 Application Circuit Block Diagram	16
5 Terminal Pin Assignment & Reference Circuit	17
5.1 Terminal Pin Assignment	17
5.2 Reference Circuit	19
6 Optical Characteristics	20
6.1 Test Conditions	20
6.2 Optical Specifications	20
6.3 Optical	20
6.4 Ghosting	23
7 Packing	24
8 Precautions	26
9 Definition of Labels	28

List of Figures

Figure 1-1 EPD Drawing..... 11

Figure 3-1 Test Pattern of Panel 15

Figure 3-2 Image Update Current Profile..... 15

Figure 3-3 Current Measurement 15

Figure 4-1 Application Circuit Block Diagram 16

Figure 5-1 EPD Reference Circuit 19

Figure 6-1 Optical measurement..... 21

Figure 6-2 Definition of Viewing Angle to Measure Contrast Ratio..... 22

Figure 7-1 Packing Diagram 24

Figure 9-1 Model Labels..... 28

Figure 9-2 Definition of Model Labels..... 28

Figure 9-3 Carton Label 29

Figure 9-4 Pallet Label..... 29

List of Tables

Table 1-1 General Specification 9

Table 1-2 Mechanical Specification 10

Table 1-3 FPC Specification 10

Table 2-1 Absolute Ratings of Environment 12

Table 2-2 Reliability Test Items 13

Table 3-1 Absolute Maximum Ratings of Panel 14

Table 3-2 Recommended Operation Conditions of Panel 14

Table 5-1 Terminal Pin Assignment 17

Table 6-1 Optical Measurement Conditions 20

Table 6-2 Optical Measurement with D65 light source 20

Table 6-3 Measurement of Ghosting 23

Revision History

Version	Date	Page (New)	Section	Description
Ver.01	2014/11/07	All	All	Product specification first issued.
Ver.02	2015/02/02	9	1.4	Table 1-1, Add driver IC.
		28	9	Figure 9-1, Add model labels dimension.
Ver.03	2015/06/11	1,2	Cover page	Modified company address.
		12	2.1	1.Note (1), add (d) item 2.Delete Figure 2-1
		17	5.1	Modify “ Terminal Pin Assignment” Pin 8
		19	5.2	Modify “Figure 5-1 EPD Reference Circuit”
		21	6.2.1	Modify ”Figure 6-1 Optical measurement with “Face up” note
Ver.04	2016/04/08	11	1.5	Modify “Figure 1- 1 EPD Drawing”, add silicon
		24,25	7	1. Modify carton label size & position 2. Modify “Figure 7-1” Pallet packing way
		27	8	Precautions: add item (23)
		29	9	Modify Figure 9-3 carton label to 100* 100mm

Glossary of Acronyms

EPD	Electrophoretic Display (e-Paper Display)
EPD Panel	EPD
EPD Module	EPD with TCon board
TCon	Timing Controller
TFT	Thin Film Transistor
MCU	Microcontroller Unit
FPC	Flexible Printed Circuit
FPL	Front Plane Laminate
SPI	Serial Peripheral Interface
COG	Chip on Glass
PDI	Pervasive Displays Incorporated

1 General Description

1.1 Overview

This is a 1.9" a-Si, active matrix TFT, Electronic Paper Display (EPD) panel. The panel has such high resolution (101.6dpi) that it is able to easily display fine patterns. Due to its bi-stable nature, the EPD panel requires very little power to update and needs no power to maintain an image.

1.2 Features

- a-Si TFT active matrix Electronic Paper Display(EPD)
- Resolution: 144 x 128
- Ultra low power consumption
- Super Wide Viewing Angle - near 180°
- Extra thin & light
- SPI interface
- RoHS compliant

1.3 Applications

- Electronic shelf label (ESL)
- Reusable container
- Badge

1.4 General Specifications

Table 1-1 General Specification

Item	Specification	Unit	Note
Outline Dimension	42.0(H) x 42.9(V) x 1.1(T)	mm	(1)
Active Area	36.0(H) x 32.0(V)	mm	
Driver Element	a-Si TFT active matrix	-	
FPL	Aurora Mb	-	
Pixel Number	144 x 128	pixel	
Pixel Pitch	0.250 x 0.250 (101.6dpi)	mm	
Pixel Arrangement	Vertical stripe	-	
Display Colors	Black/White	-	
Surface Treatment	Anti-Glare	-	
Driver IC	G2	-	-

Note (1): Not including the FPC.

1.5 Mechanical Specifications

Table 1-2 Mechanical Specification

Item		Min.	Typ.	Max.	Unit	Note
Glass Size	Horizontal(H)	41.7	42.0	42.3	mm	
	Vertical(V)	42.6	42.9	43.2	mm	
	Thickness(T)	1.3	1.5	1.7	mm	(1)
Weight		-	3.8	4.6	g	

Note (1): Not including the Masking Film.

Table 1-3 FPC Specification

Item	Pin numbers	Pitch (mm)	Connector	Note
Golden Finger	40	0.5	STARCONN 089H40 or HRS TF31-40S or Compatible	

Figure 1-1 EPD Drawing

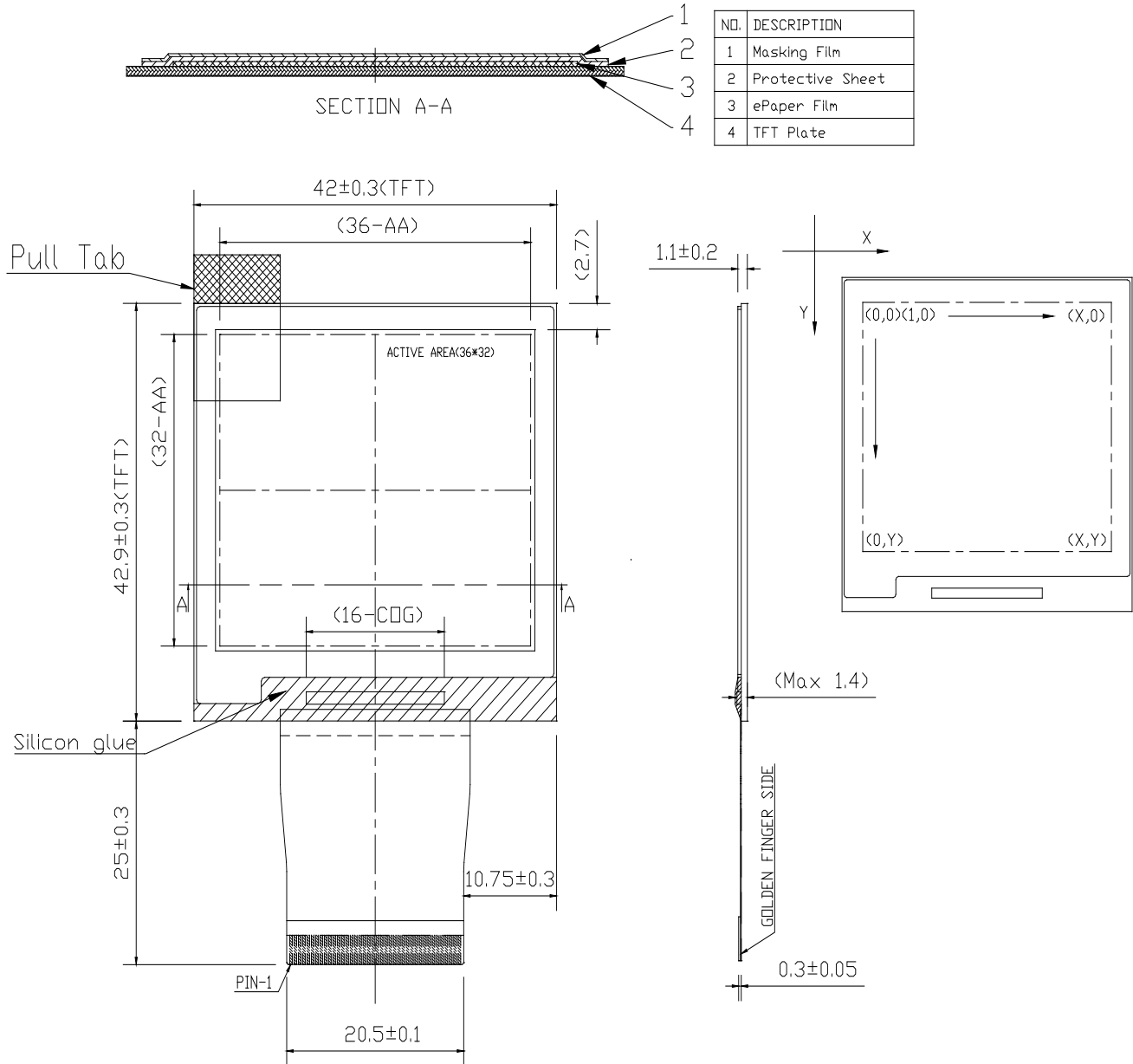

General tolerance: $\pm 0.3\text{mm}$

2 Absolute Maximum Ratings

2.1 Absolute Ratings of Environment

Table 2-1 Absolute Ratings of Environment

Item	Symbol	Value		Unit	Note
		Min.	Max.		
Storage Temperature	T _{ST}	-20	+ 60	°C	(1), (3)
Operating Ambient Temperature	T _{OP}	0	+ 50	°C	(1), (2), (3)

Note (1):

- (a) 90 %RH Max. ($T_a \leq 40 \text{ }^\circ\text{C}$), where T_a is ambient temperature.
- (b) Wet-bulb temperature should be 39 °C Max. ($T_a > 40 \text{ }^\circ\text{C}$).
- (c) No condensation and no frost.
- (d) If users like to put the EPD under some extreme condition (e.g. +60C, < 40% RH), the lifetime of EPD may be shorter than warranty lifetime. Please contact PDI sales respective for details.

Note (2): The temperature of panel display surface area should be 0 °C Min. and 50 °C Max. Refresh time depends on operating temperature.

Note (3): In order to keep good performance of EPD, please refer to precaution for storage condition.

2.2 Reliability Test Item

Table 2-2 Reliability Test Items

Item	Test Condition	Remark
High Temperature Operation	50 °C / 30 %RH for 240h	(1) (2)
Low Temperature Operation	0 °C for 240h	(1) (2)
High Temperature/Humidity Operation	40 °C / 90 %RH for 168h	(1) (2)
High Temperature Storage	60 °C / 26 %RH for 240h	(1)(2)(3)
Low Temperature Storage	-20 °C for 240h	(1)(2)(3)
High Temperature/Humidity Storage	50 °C / 80 %RH for 168h	(1)(2)(3)
Thermal Cycles (Non-operation)	1 Cycle:-20°C/30min → 60°C/30min, for 100 Cycles	(1)(2)(3)
Package Drop Test	Drop from 97cm. (ISTA) 1 corner, 3 edges, 6 sides. One drop for each.	(1)(2)(3)
Package Random Vibration Test	1.15Grms, 1Hz ~ 200Hz. (ISTA)	(1)(2)(3)

Note (1): No condensation and no frost during test. End of test, function, mechanical, and optical shall be satisfied.

Note (2): The test result and judgment are based on PDI's 1bit driving waveform, driving fixture and driving system.

Note (3): Stay white pattern for storage and non-operation test.

3 Electrical Characteristics

3.1 Absolute Maximum Ratings of Panel

Table 3-1 Absolute Maximum Ratings of Panel

Parameter	Symbol	Value		Unit	Note
		Min	Max		
Digital Power	V _{DD}	-0.3	6.0	V	
Analog Power	V _{CC}	-0.3	6.0	V	
Ground	V _{SS}	-		-	Connect V _{SS} to Ground

T_a = 25 ± 2 °C

3.2 Recommended Operation Conditions of Panel

Table 3-2 Recommended Operation Conditions of Panel

Parameter	Symbol	Value			Unit	Note
		Min	Typ	Max		
Digital Power	V _{DD}	2.3	3.0	3.6	V	
Analog Power	V _{CC}	2.3	3.0	3.6	V	
Input Voltage	High	V _{IH}	0.8V _{DD}	-	V _{DD}	/CS, ID, SCLK, SI, /RESET
	Low	V _{IL}	V _{SS}	-	0.2V _{DD}	
Output Voltage	High	V _{OH}	0.8V _{DD}	-	V _{DD}	I _{OH} = 0.5mA, SO, BUSY
	Low	V _{OL}	V _{SS}	-	0.2V _{DD}	I _{OL} = -0.5mA, SO, BUSY
Input Leakage Current	High	I _{IH}	-	-	2.0	uA
	Low	I _{IL}	-	-	-2.0	uA
Input Current	I _{DD} + I _{CC}	-	4	8	mA	(1),(2),(3)
DC/DC Inrush Current	I _{PEAK}	-	30	90	mA	(1),(2),(3)

T_a = 25 ± 2 °C

Note (1):

Figure 3-1 Test Pattern of Panel



These currents are tested with PDI test jig.

Note (2):

$$V_{DD} = V_{CC} = 3.0V$$

Figure 3-2 Image Update Current Profile

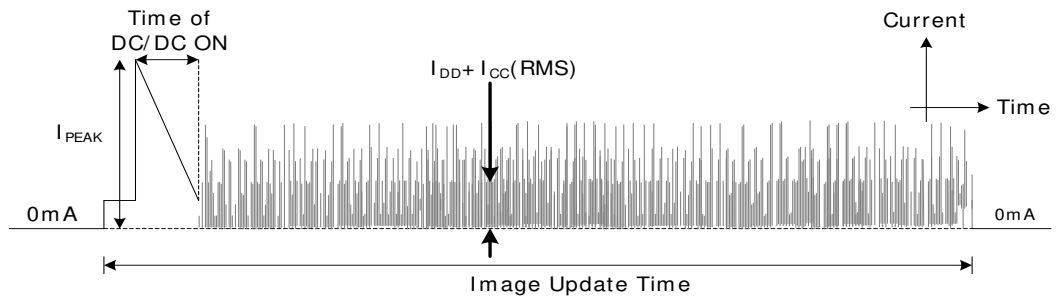

The “Time of DC/DC ON” which contains the some current peak of $V_{GH}/V_{DH}/V_{GL}/V_{DL}/V_{COM}$.

Note (3):

Figure 3-3 Current Measurement

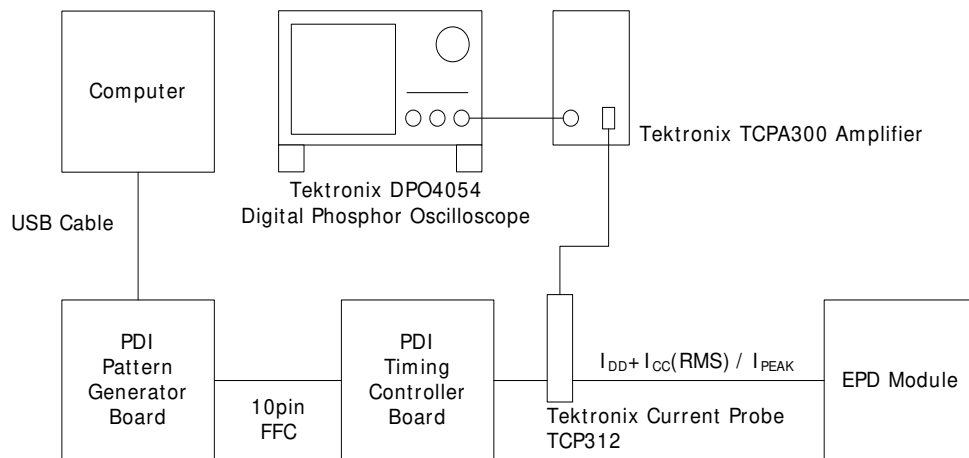

4 Application Circuit Block Diagram

Figure 4-1 Application Circuit Block Diagram

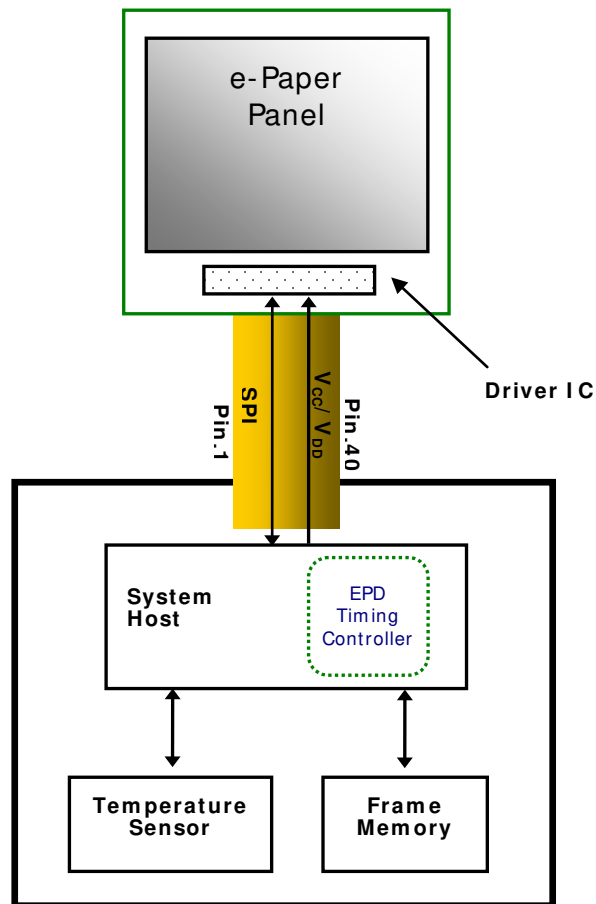

5 Terminal Pin Assignment & Reference Circuit

5.1 Terminal Pin Assignment

Table 5-1 Terminal Pin Assignment

No.	Signal	Type	Connected to	Function
1	/CS	I	Tcon	Chip Select. Low enable
2	BUSY	O	Tcon	When BUSY = HIGH, EPD stays in busy state that EPD ignores any input data from SPI
3	ID	I	Ground	Connect ID to ground
4	SCLK	I	Tcon	Clock for SPI
5	SI	I	Tcon	Serial input from Timing Controller to EPD
6	SO	O	Tcon	Serial output from EPD to Timing Controller
7	/RESET	I	Tcon	Reset signal. Low enable
8	PWRON	-	NC	Keep open
9	VCL	C	Capacitor	
10	C42P	-	NC	Not Connected
11	C42M	-		
12	C41P	C	Charge-Pump Capacitor	
13	C41M	C		
14	C31M	C	Charge-Pump Capacitor	
15	C31P	C		
16	C21M	C	Charge-Pump Capacitor	
17	C21P	C		
18	C16M	C	Charge-Pump Capacitor	
19	C16P	C		
20	C15M	C	Charge-Pump Capacitor	
21	C15P	C		

22	C14M	C	Charge-Pump Capacitor	
23	C14P	C		
24	C13M	C	Charge-Pump Capacitor	
25	C13P	C		
26	C12M	C	Charge-Pump Capacitor	
27	C12P	C		
28	C11M	C	Charge-Pump Capacitor	
29	C11P	C		
30	V _{COM_DRIVER}	RC	Resistor & Capacitor	The signal duty cycle can drive V _{COM} voltage from source driver IC
31	V _{CC}	P	V _{CC}	Power supply for analog part of source driver
32	V _{DD}	P	V _{DD}	Power supply for digital part of source driver
33	V _{SS}	P	Ground	
34	V _{GH}	C	Capacitor	
35	V _{GL}	C	Capacitor	
36	V _{DH}	C	Capacitor	
37	V _{DL}	C	Capacitor	
38	BORDER	-	-	Not connected
39	V _{ST}	P	V _{COM_PANEL}	
40	V _{COM_PANEL}	C	Capacitor	V _{COM} to panel

Note:

Type: I: Input
 O: Output
 C: Capacitor
 RC: Resistor and Capacitor
 P: Power

5.2 Reference Circuit

Figure 5-1 EPD Reference Circuit

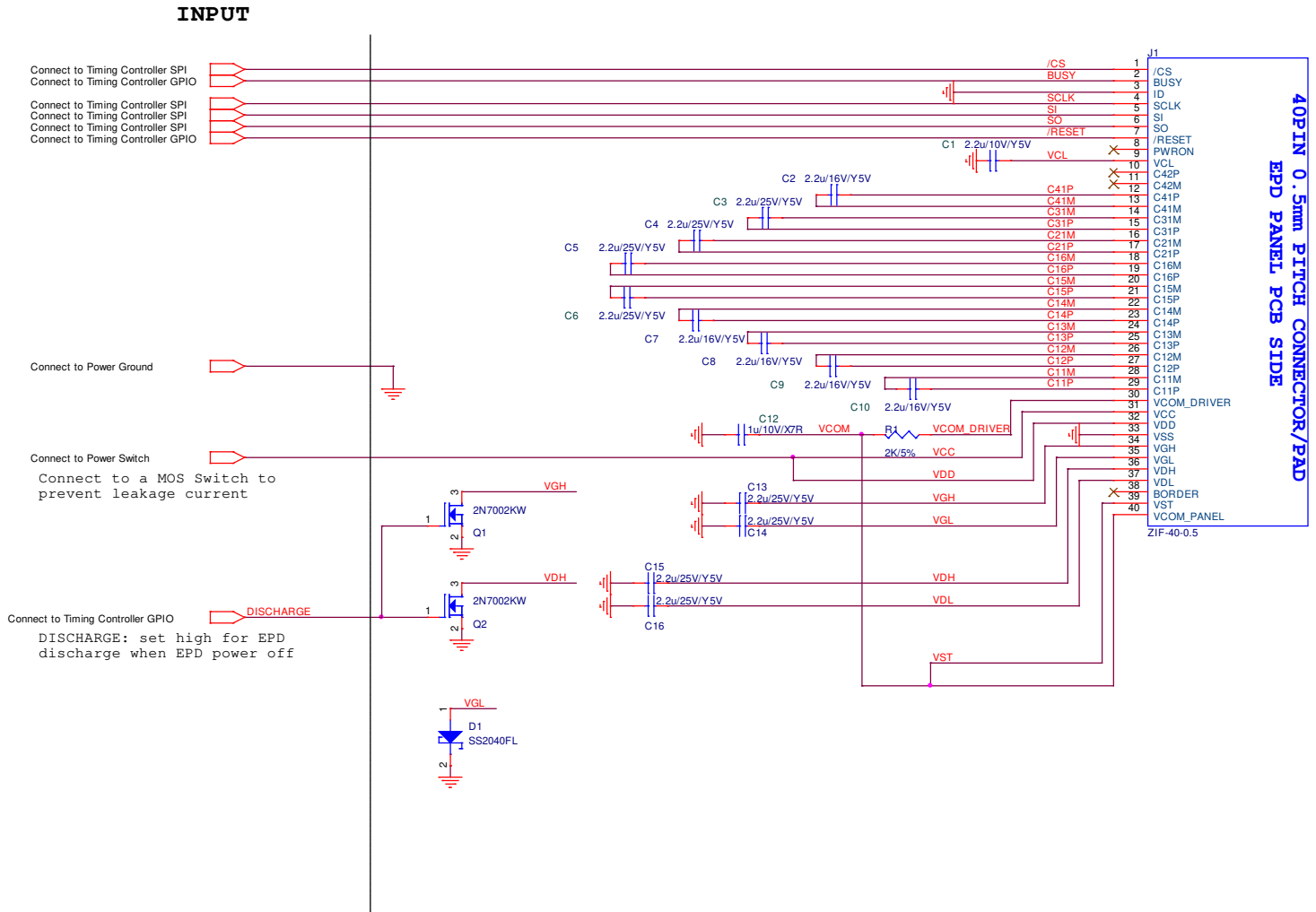

Note: (1) V_{DD} and V_{CC} must be discharged promptly after power off.

6 Optical Characteristics

6.1 Test Conditions

Table 6-1 Optical Measurement Conditions

Item	Symbol	Value	Unit
Ambient Temperature	Ta	25±2	°C
Ambient Humidity	Ha	50±10	%RH
Supply Voltage	V _{CC} & V _{DD}	3.0	V

Note: Measure optical at RT (Room Temperature) after pattern update at 25 °C.

6.2 Optical Specifications

6.3 Optical

Table 6-2 Optical Measurement with D65 light source

Item	Symbol	Rating			Unit	Note
		Min.	Typ.	Max.		
Contrast ratio	CR	-	7:1	-	-	$\theta_x = \theta_y = 0$ (1),(2),(3),(4)
Refresh time	Tr	-	2	-	sec	(3)
White Chromaticity	Wx	-	0.308	-	-	$\theta_x = \theta_y = 0$ (1),(4)
	Wy	-	0.331	-		
Reflectance	R%	-	32	-	%	(1),(4)

Note (1): Panel is driven by PDI waveform without masking film and optical measurement by CM-700D with D65 light source and SCE mode.

Figure 6-1 Optical measurement

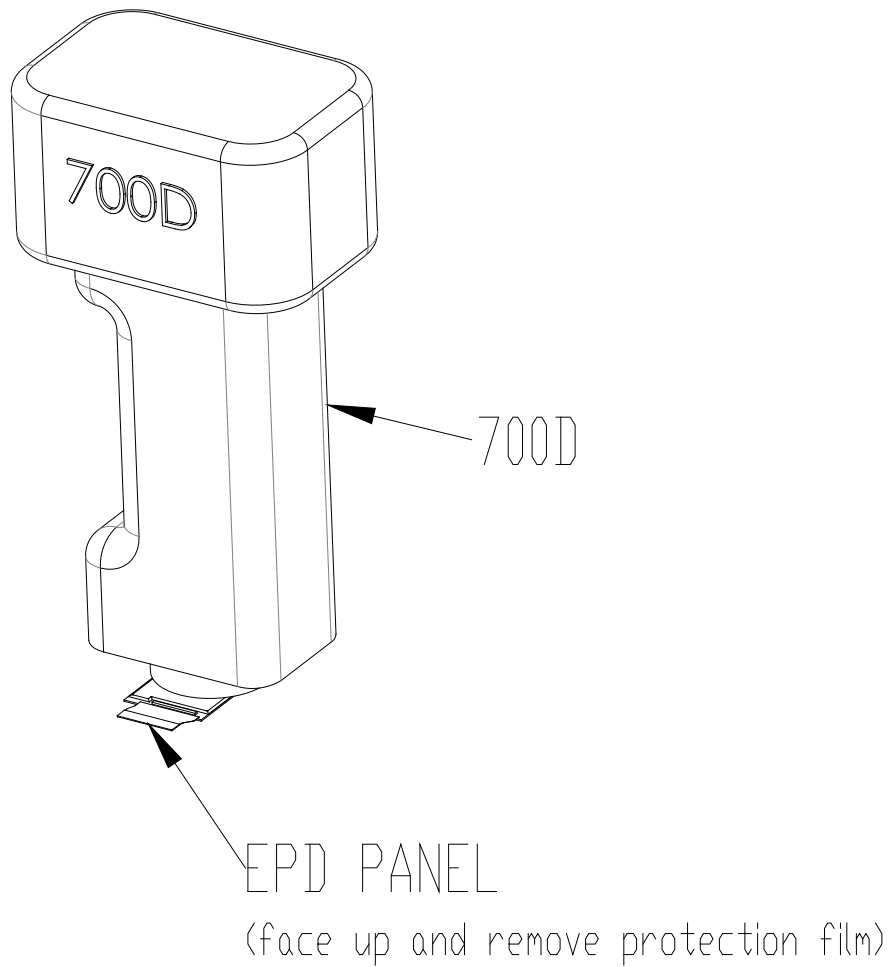

SCE mode

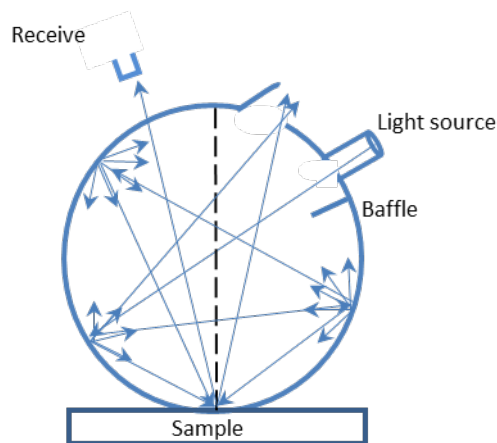

Note (2): Definition of Viewing Angle (θ_x , θ_y):

Figure 6-2 Definition of Viewing Angle to Measure Contrast Ratio

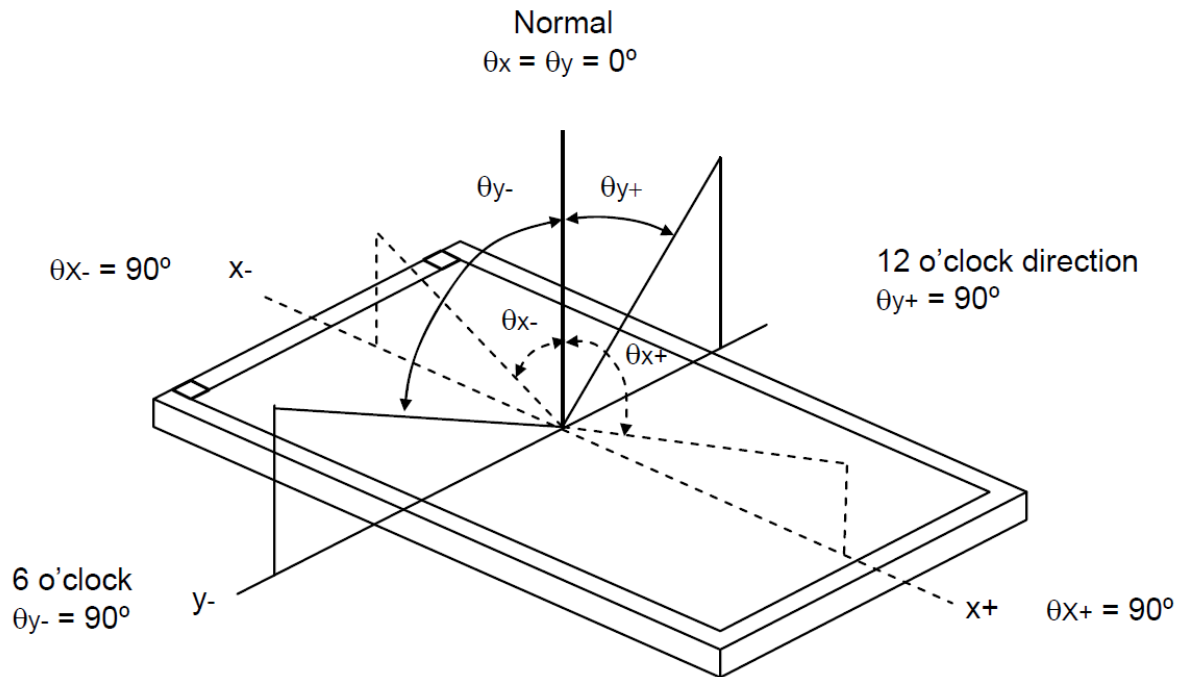

Note (3): Refresh time is the time that e-paper particles move not including the power on and off time. The refresh time is measured at 25°C. The refresh time and contrast ratio varies due to different films, display performance requirements, and ambient temperatures.

Note (4): Contrast ratio (C.R.): The Contrast ratio is calculated by the following expression. $C.R. = (R\% \text{ White}) / (R\% \text{ Black})$. Reflectance is measured at 120 seconds after refresh.

6.4 Ghosting

Below are two test methods to verify that ghosting within an acceptable range. Test 1 and Test 2 use measured data to calculate Delta E which is a single number representing the distance between two colors in a 3 dimensional color space. Test 1 and 2 are performed at 25° C.

- Test 1: White to Black Ghosting

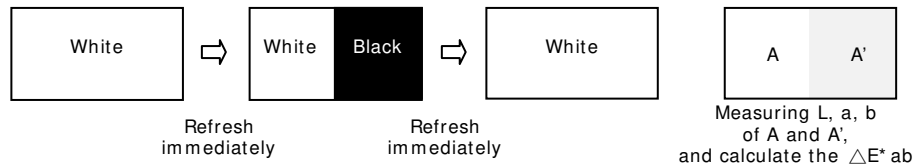

- Test 2: Black to White Ghosting

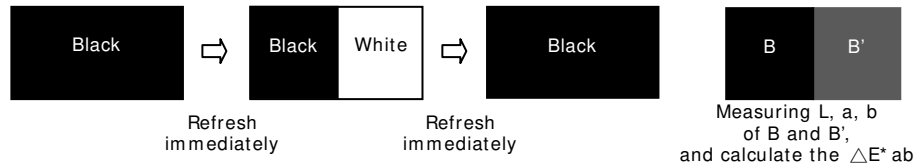

The formula is used to calculate Test1 and Test2. For example of Test 2:

$$\Delta E^* ab = [(L_B - L_{B'})^2 + (a_B - a_{B'})^2 + (b_B - b_{B'})^2]^{1/2}$$

Table 6-3 Measurement of Ghosting

Item	Rating		
	Min.	Typ.	Max.
Test 1 ΔE*ab	-	-	2
Test 2 ΔE*ab	-	-	2

Note: Panel is driven by PDI waveform without masking film and optical measurement by CM-700D with D65 light source and SCE mode.

7 Packing

Figure 7-1 Packing Diagram

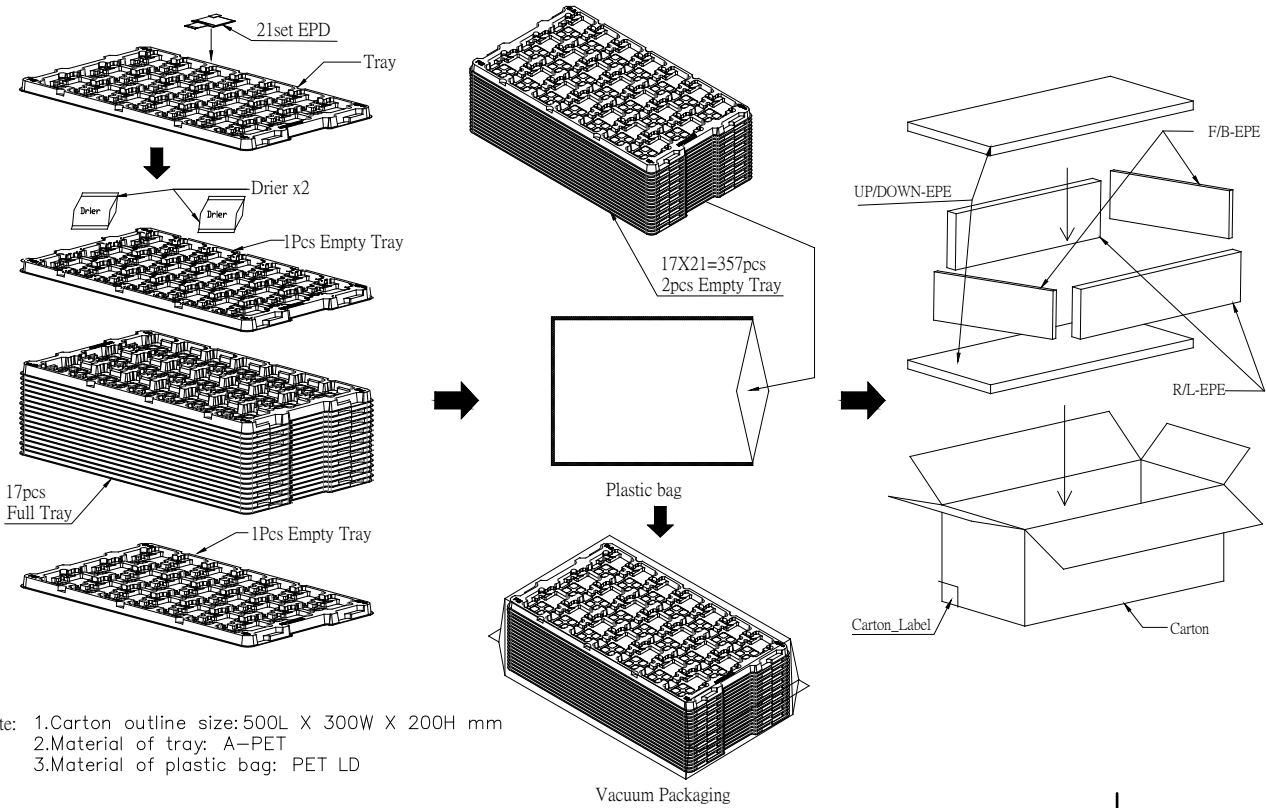

- Note: 1. Carton outline size: 500L X 300W X 200H mm
 2. Material of tray: A-PET
 3. Material of plastic bag: PET LD

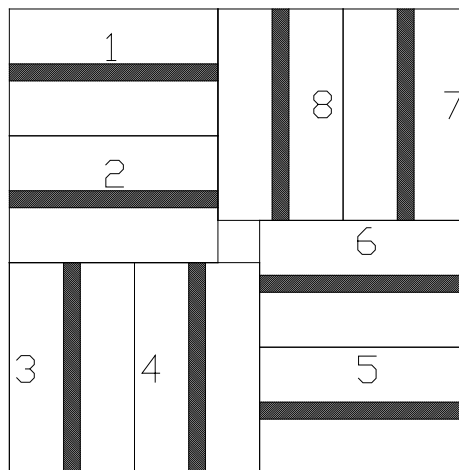

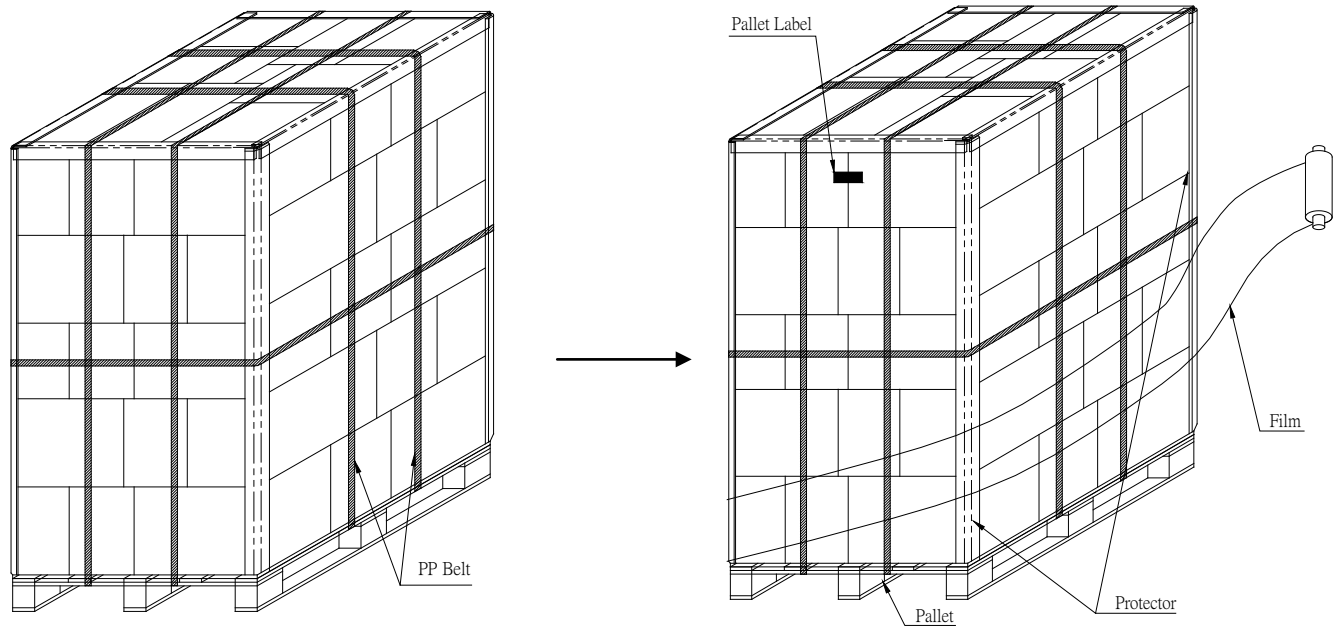

357(pcs) x 40(BOX) = 14,280pcs

	1.9" EPD BOX
N.W. :	1.36 Kg
G.W. :	4.72 Kg

Sea / Land / Air Transportation

