



Chipsmall Limited consists of a professional team with an average of over 10 year of expertise in the distribution of electronic components. Based in Hongkong, we have already established firm and mutual-benefit business relationships with customers from,Europe,America and south Asia,supplying obsolete and hard-to-find components to meet their specific needs.

With the principle of "Quality Parts,Customers Priority,Honest Operation,and Considerate Service",our business mainly focus on the distribution of electronic components. Line cards we deal with include Microchip,ALPS,ROHM,Xilinx,Pulse,ON,Everlight and Freescale. Main products comprise IC,Modules,Potentiometer,IC Socket,Relay,Connector.Our parts cover such applications as commercial,industrial, and automotives areas.

We are looking forward to setting up business relationship with you and hope to provide you with the best service and solution. Let us make a better world for our industry!



Contact us

Tel: +86-755-8981 8866 Fax: +86-755-8427 6832

Email & Skype: info@chipsmall.com Web: www.chipsmall.com

Address: A1208, Overseas Decoration Building, #122 Zhenhua RD., Futian, Shenzhen, China



Easy mounting photoelectric sensor in short M18 housing

E3FZ/E3FR

- Secure-click snap mounting for fast installation
- High power LED for enhanced sensing distance
- Short housing with less than 40 mm length
- Minimal optical axis deviation for easy alignment



Features

Easy and fast installation

The **SecureClick** snap mounting mechanism provides easy installation in 2 steps and enhanced protection against vibration.

Installation time can be reduced by up to 10 times compared to conventional sensors.

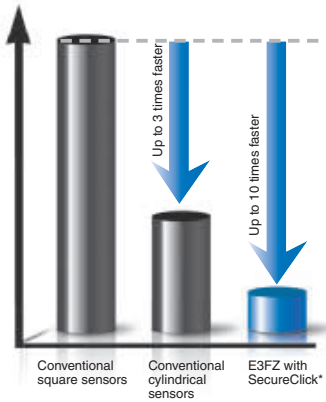



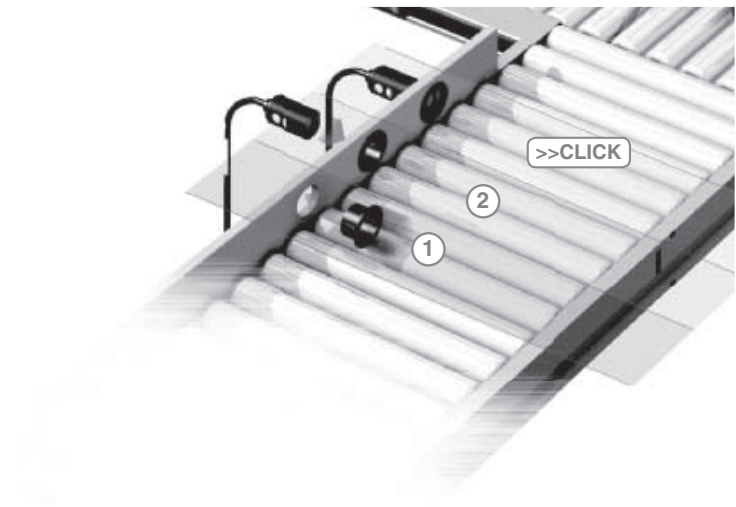





*SecureClick has been tested to withstand severe vibrations.









Ordering Information

Snap mounting – E3FZ^{*2}

Sensor type	Sensing distance	Connection method				Order code	
						NPN output	PNP output
Through-beam 	15 m	-	-	2 m	_*3	E3FZ-T61H 2M	E3FZ-T81H 2M
		-	■	-	_*3	E3FZ-T66H	E3FZ-T86H
Retroreflective with M.S.R. 	0.1 to 4 m ^{*1}	-	-	2 m	_*3	E3FZ-R61H 2M	E3FZ-R81H 2M
		-	■	-	_*3	E3FZ-R66H	E3FZ-R86H
Diffuse reflective 	1 m (adjustable)	-	-	2 m	_*3	E3FZ-D62 2M	E3FZ-D82 2M
		-	■	-	_*3	E3FZ-D67	E3FZ-D87
Diffuse reflective (background suppression) 	100 mm (fixed)	-	-	2 m	_*3	E3FZ-LS61H 2M	E3FZ-LS81H 2M
		-	■	-	_*3	E3FZ-LS66H	E3FZ-LS86H
	200 mm (fixed)	-	-	2 m	_*3	E3FZ-LS64H 2M	E3FZ-LS84H 2M
		-	■	-	_*3	E3FZ-LS69H	E3FZ-LS89H

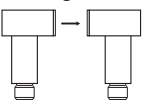
Radial mounting – E3FR

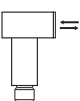
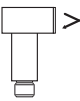
Sensor type	Sensing distance	Connection method				Order code	
						NPN output	PNP output
Through-beam 	15 m	-	-	2 m	_*3	E3FR-T61H 2M	E3FR-T81H 2M
		-	■	-	_*3	E3FR-T66H	E3FR-T86H
Retroreflective with M.S.R. 	0.1 to 4 m ^{*1}	-	-	2 m	_*3	E3FR-R61H 2M	E3FR-R81H 2M
		-	■	-	_*3	E3FR-R66H	E3FR-R86H
Diffuse reflective 	1 m (adjustable)	-	-	2 m	_*3	E3FR-D62 2M	E3FR-D82 2M
		-	■	-	_*3	E3FR-D67	E3FR-D87
Diffuse reflective (background suppression) 	100 mm (fixed)	-	-	2 m	_*3	E3FR-LS61H 2M	E3FR-LS81H 2M
		-	■	-	_*3	E3FR-LS66H	E3FR-LS86H
	200 mm (fixed)	-	-	2 m	_*3	E3FR-LS64H 2M	E3FR-LS84H 2M
		-	■	-	_*3	E3FR-LS69H	E3FR-LS89H



*1. Measured with reflector E39-R1S
The reflector is sold separately.

*2. Mounting with Snap-Holder (provided with product) or M18 Nuts (provided with product) possible.



*3. Pre-wired connectors are available on request (item description see "Model Number Legend" on page 4)

Accessories



Reflectors

Shape	Type	Material	Features	Size in mm	Applicable Sensor	Order code
	General purpose reflectors	- ABS base - Acrylic surface	Surface screw mounting (diagonal holes)	59.9x40.3x7.5	- Retroreflective photo electric sensors – non polarizing - Retroreflective photo electric sensors – polarizing (MSR)	E39-R1S
			Snap mounting	dia 30 mm (reflector) dia 6.5 mm (snap mount)		E39-R49

Mounting brackets

Shape	Type	Material	Features	Applicable Sensor	Order code
	General purpose mounting	stainless steel	Horizontal angle adjustment	E3FZ (dia 20mm snap holder)	E39-EL8
	Telescope mounting		3D rotation (fits to 12 mm mounting rod)		E39-EL9

Sensor I/O connectors

Straight		2 m	4-wire	PVC	XS2F-D421-D80-A
				PUR	Y92E-M12PUR4S2M-L
		5 m		PVC	XS2F-D421-G80-A
		PUR		Y92E-M12PUR4S5M-L	
L-shaped		2 m	4-wire	PVC	XS2F-D422-D80-A
				PUR	Y92E-M12PUR4A2M-L
		5 m		PVC	XS2F-D422-G80-A
		PUR		Y92E-M12PUR4A5M-L	

Note: For the complete list of sensor I/O connectors refer to E26E Accessories datasheet.

Model Number Legend

E3F□-□□□□-□-□□
 1 2 3 4 5 6 7 8 9

e.g., E3FZ-T81H; short housing/ through-beam/PNP output/2 m cable/without an adjustor/L-on/D-on by wire/

E3FZ-T86H-D; short housing/through-beam/PNP output/M12 connector/without an adjustor/L-on/D-on by wire/receiver

E3FR-LS86; radial housing/background-suppression/PNP output/M12 connector/sensing distance of 100 mm/without an adjustor/
 L-on/D-on by wire/

1. Cylindrical family name: E3F
2. Series name
 - 2: standard housing (seperate naming rule)
 - Z: short housing
 - R: radial housing
3. Sensing method
 - T: through-beam
 - R: retroreflective
 - D: diffuse reflective
 - LS: background suppression
4. Output
 - 6: NPN output
 - 8: PNP output
5. Connection
 - Through-beam, retroreflective types
 - 1: 2 m cable
 - 6: M12 connector
 - Diffuse reflective types
 - 2: 2 m cable
 - 7: M12 connector
 - Background suppression types
 - 1: 2 m cable/sensing distance of 100 mm
 - 4: 2 m cable/sensing distance of 200 mm
 - 6: M12 connector/sensing distance of 100 mm
 - 9: M12 connector/sensing distance of 200 mm
6. Adjuster
 - Blank: with volume adjuster/L-on/D-on by wire
 - H: without volume adjuster/L-on/D-on by wire
7. Emitter/ Receiver
 - L: emitter
 - D: receiver
8. Kind of connection
 - Blank: standard 2 m cable or M12 connector
 - M1J: pre-wired with 30 cm cable and M12 plug connector (4 pin)
 - M3J: pre-wired with 30 cm cable and M8 plug connector (4 pin)
 - M5J: pre-wired with 30 cm cable and M8 plug connector (3 pin)
 - M1TJ: pre-wired with 30cm cable and Twist&Click M12 plug connector (4 pin)
9. Cable length
 - Blank: M12 connector
 - Number: cable length

Mounting and dismounting

Mounting

Step 1

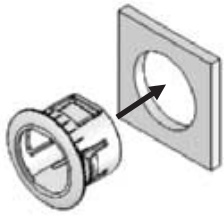

Insert the snap holder into the mounting hole from the front



Verify the correct position (a clicking sound can be heard)

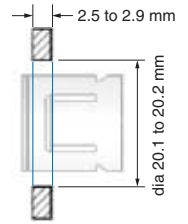

Step 2

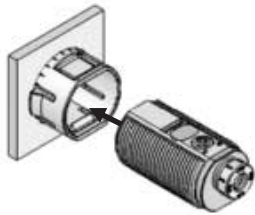

Insert the sensor into the snap holder from the back

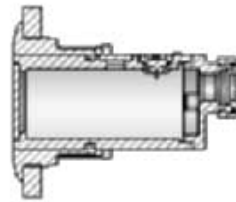

Verify the correct position (a clicking sound can be heard)

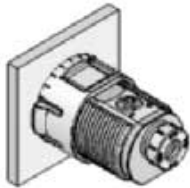

Dismounting

Step 1

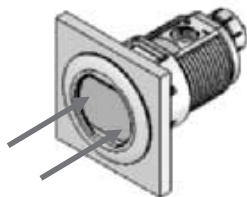

Apply soft pressure to the sensor lens in the indicated areas (e.g. with two thumbs)

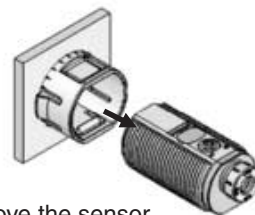

Remove the sensor

Step 2

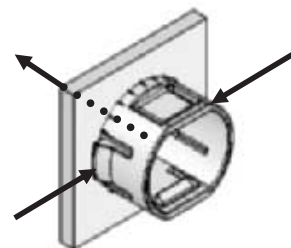

Press down both snap-fits and push the snap holder forward.

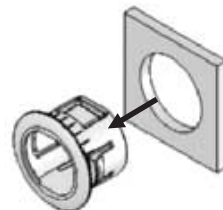

Remove the snap holder

Specifications

Item	Through-beam		Retroreflective	Diffuse reflective
	E3FZ-T / E3FR-T		E3FZ-R / E3FR-R	E3FZ-D / E3FR-D
Sensing distance	15 m		4 m [100 mm]	1 m (white paper 300x300 mm)
Spot diameter	-			
Standard sensing object	Opaque: 12 mm dia. min		Opaque: 75 mm dia. min	-
Differential travel	-			20% max. of sensing distance max.
Black/white error	-			
Directional angle	Emitter and Receiver: 3° to 15°		Sensor: 3° to 10°, Reflector: 30°	-
Light source (wave length)	Infrared LED (870 nm)		Red LED (660 nm)	Infrared LED (860 nm)
Power supply voltage	10 to 30 VDC, including 10% ripple(p-p)			
Current consumption	45mA max. (Emitter: 25mA max., Receiver; 20 mA max.)		25 mA max.	
Control output	Load power supply voltage; 30 VDC max., Load current; 100 mA max.(Residual voltage; 2 V max.), Light-on/Dark-on selectable by wire, E3F□-6□: NPN open-collector output E3F□-8□: PNP open-collector output			
Protective circuits	Power supply reverse polarity protection, output short-circuit protection, and reversed output polarity protection		Power supply reverse polarity protection, output short-circuit protection, mutual interference prevention and reversed output polarity protection	
Response time	Operate and reset; 1 ms max.			
Sensitivity adjustment	-			One-turn adjuster
Ambient illumination (receiver side)	Incandescent lamp; 3000 lx max., Sunlight 10000 lx max.			
Ambient temperature	Operating; -25 to +55°C, Storage; -40 to +70°C (with no icing or condensation)			
Ambient humidity	Operating; 35 to 85% RH, Storage; 35 to 95% RH (with no condensation)			
Insulation resistance	20MΩ min. at 500 VDC			
Dielectric resistance	1000 VAC at 50/60 Hz for 1 min			
Vibration resistance	Destruction; 10 to 55 Hz, 1.5 mm double amplitude for 2 hours, each in X, Y and Z directions			
Shock resistance	Destruction; 500 m/s ² , 3 times, each in X, Y and Z directions			
Degree of protection *1	IEC 60529 IP67, IP69K after DIN 40050-9			
Connection method	Pre-wired cable (standard length 2 m), Standard M12 connector			
Indicator	Operation indicator: yellow, stability indicator: green (Emitter has only power supply indicator; green)			
Weight (packed state)	Pre-wired	approx. 120 g	approx. 60 g	
	Standard connector	approx. 40 g	approx. 20 g	
Material	Case	ABS		
	Cover lens Plate window	PMMA		
Accessories	Instruction sheet, 2x M18 nuts, snap mounting tool (E3FZ only).			

*1. The IP69k test according to DIN 40 050 part 9 is intended to simulate high pressure/steam cleaning. During the test 14-16 l/min water at 80°C is sprayed onto the sensor from different angles with 8000-10000 kPa. The sensor may not suffer any damaging effects from high pressure water in appearance and functionality.

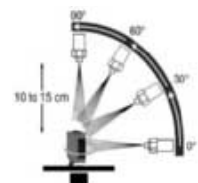

Specification

Item	Background suppression (BGS)	
	E3FZ-LS□1H / E3FR-LS□1H E3FZ-LS□6H / E3FR-LS□6H	E3FZ-LS□4H / E3FR-LS□4H E3FZ-LS□9H / E3FR-LS□9H
Sensing distance	10 to 100 mm (White paper 100x100 mm)	10 to 200 mm (White paper 100x100 mm)
Spot diameter	4 mm dia. at sensing distance of 100 mm	18 mm dia. at sensing distance of 200 mm
Standard sensing object	-	
Differential travel	3% of sensing distance max.	20% of sensing distance max.
Black/white error	5% of sensing distance max.	20% of sensing distance max.
Directional angle	-	
Light source (wave length)	Red LED (650 nm)	Red LED (660 nm)
Power supply voltage	10 to 30 VDC, including 10% ripple(p-p)	
Current consumption	25 mA max.	
Control output	Load power supply voltage; 30 VDC max., Load current; 100 mA max. (Residual voltage; 2 V max.), Light-on/Dark-on selectable by wire, E3F□-LS6: NPN open-collector output E3F□-LS8: PNP open-collector output	
Protective circuits	Power supply reverse polarity protection, output short-circuit protection, mutual interference prevention and reversed output polarity protection	
Response time	Operate and reset; 1 ms max.	
Sensitivity adjustment	-	
Ambient illumination (receiver side)	Incandescent lamp; 3000 lx max., Sunlight 10000 lx max.	
Ambient temperature	Operating; -25 to +55°C, Storage; -40 to +70°C (with no icing or condensation)	
Ambient humidity	Operating; 35 to 85%RH, Storage; 35 to 95%RH (with no condensation)	
Insulation resistance	20MΩ min. at 500 VDC	
Dielectric resistance	1000 VAC at 50/60 Hz for 1 min	
Vibration resistance	Destruction; 10 to 55 Hz, 1.5 mm double amplitude for 2 hours, each in X, Y and Z directions	
Shock resistance	Destruction; 500m/s ² , 3 times, each in X, Y and Z directions	
Degree of protection ^{*1}	IEC 60529 IP67, IP69K after DIN 40050-9	
Connection method	Pre-wired cable (standard length 2m), Standard M12 connector	
Indicator	Operation indicator: yellow, stability indicator: green	
Weight (packed state)	Pre-wired	approx.60g
	Standard connector	approx.20g
Material	Case	ABS
	Cover-lens	PMMA
	Plate-window	
Accessories	Instruction sheet, 2x M18 nuts, snap mounting tool (E3FZ only).	

^{*1}. The IP69k test according to DIN 40 050 part 9 is intended to simulate high pressure/steam cleaning. During the test 14-16 l/min water at 80°C is sprayed onto the sensor from different angles with 8000-10000 kPa. The sensor may not suffer any damaging effects from high pressure water in appearance and functionality.

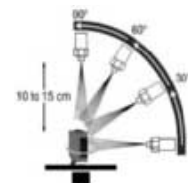

Engineering Data (typical)

Parallel Operating Range

Through-beam Models

E3F□-T□1H(T□6H)

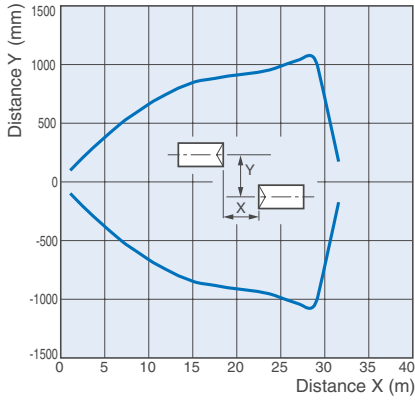

Retroreflective Models

E3F□-R□1H(R□6H)

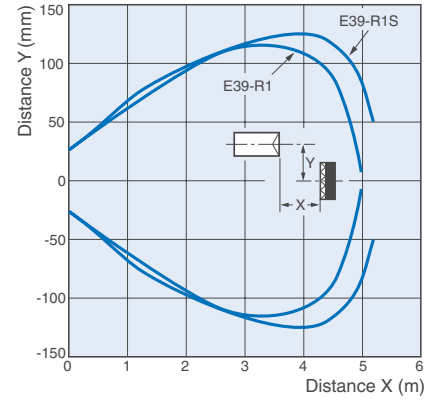

Operating Range

Diffuse reflective Models

E3F□-D□2(D□7)

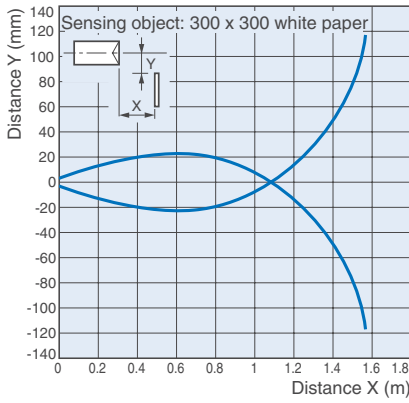

BGS Models

E3F□-LS□1H(LS□6H), left to right

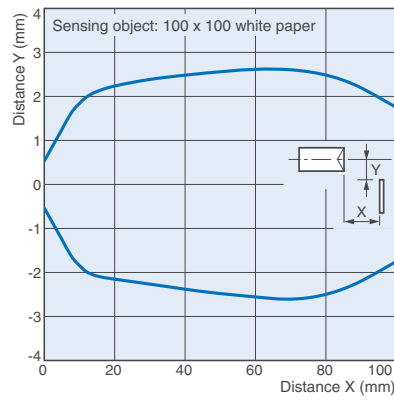

E3F□-LS□4H(LS□9H), left to right

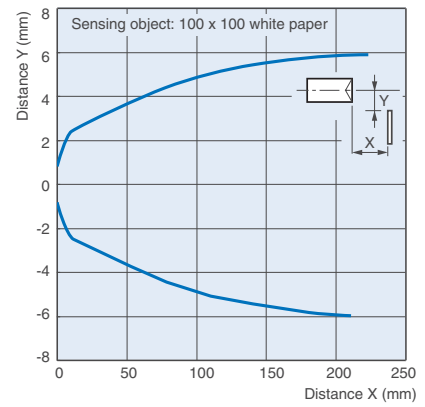

Excess Gain vs. Distance

Through-beam Models

E3F□-T□1H(T□6H)

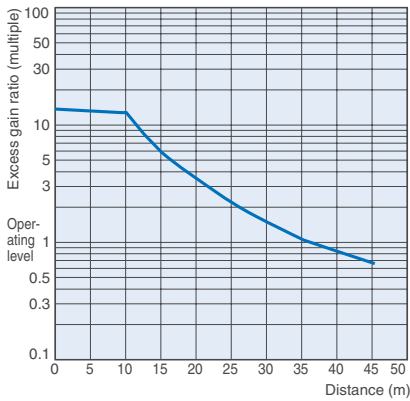

Retroreflective Models

E3F□-R□1H(R□6H)

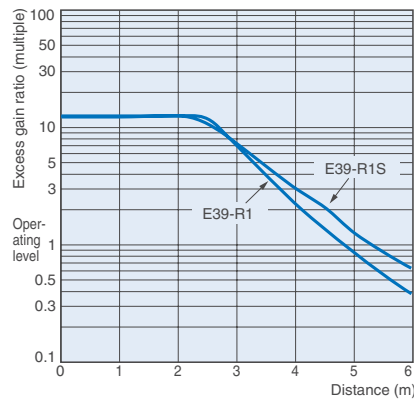

Diffuse reflective Models

E3F□-D□2(D□7)

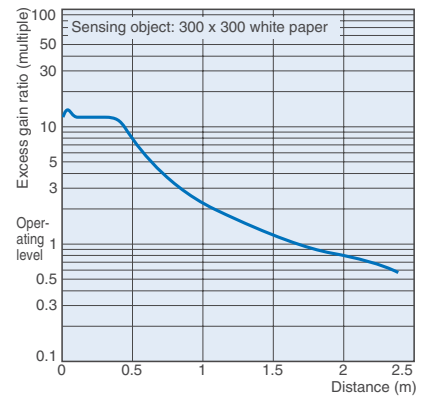

Sensing Object Size vs. Distance

Diffuse reflective Models

E3F□-D□2(D□7)

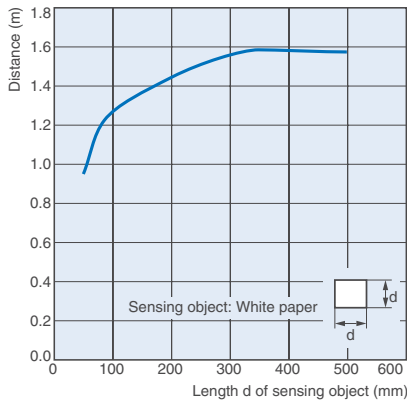

Spot Diameter vs. Distance

BGS Models

E3F□-LS□1H(LS□6H)

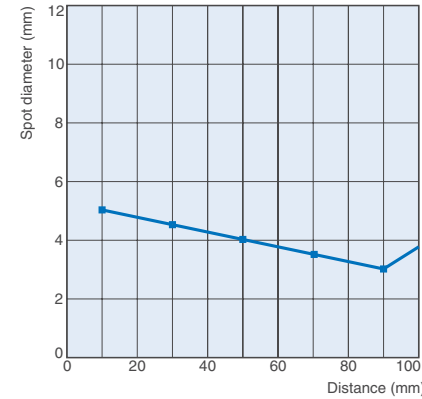

E3F□-LS□4H(LS□9H)

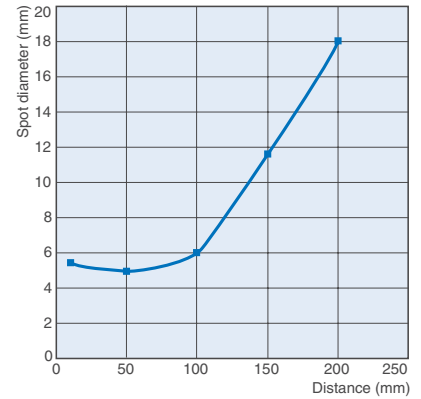

Sensing Distance vs. Sensing Object Material

BGS Models

E3F□-LS□1H(LS□6H)

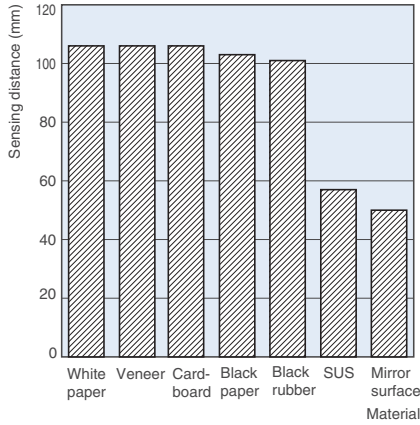

E3F□-LS□4H(LS□9H)

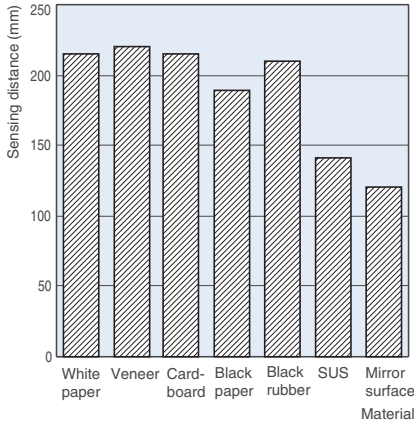

Inclination Characteristics (Vertical)

BGS Models

E3F□-LS□1H(LS□6H)

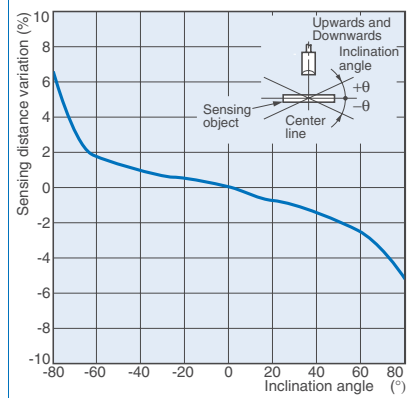

Inclination Characteristics (Horizontal)

BGS Models

E3F□-LS□1H(LS□6H)

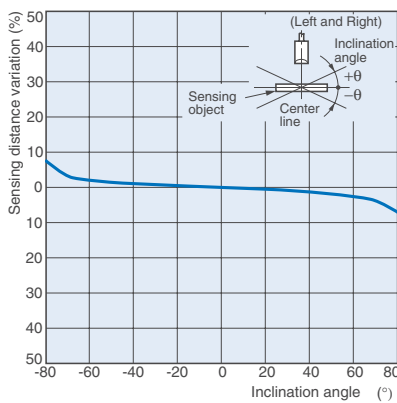

E3F□-LS□4H(LS□9H)

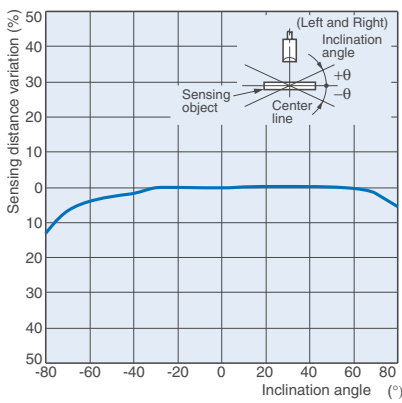

E3F□-LS□4H(LS□9H)

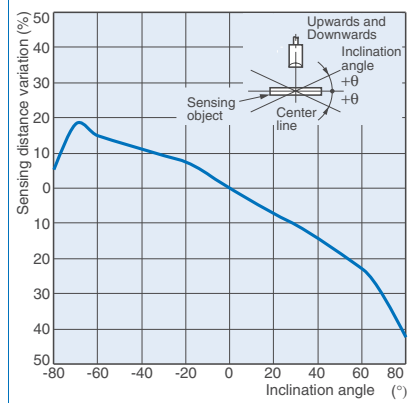

Output Circuit Diagram

PNP Output

Model	Operation mode	Timing charts	Mode selector switch	Output circuit
E3F□-T8 E3F□-R8 E3F□-D8	Light ON		Connect the pink wire (Pin(2)) to the brown wire (Pin(1)) or open the pink wire (Pin(2)).	<p>Through-beam Receivers, retroreflective models, diffuse reflective models</p>
	Dark ON		Connect the pink wire (Pin(2)) to the blue wire (Pin(3)).	
<p>Through-beam Emitter</p>				
E3F□-LS8	Light ON		Connect the pink wire (Pin(2)) to the brown wire (Pin(1)) or open the pink wire (Pin(2)).	
	Dark ON		Connect the pink wire (Pin(2)) to the blue wire (Pin(3)).	

NPN Output

Model	Operation mode	Timing charts	Mode selector switch	Output circuit
E3F□-T6 E3F□-R6 E3F□-D6	Light ON		Connect the pink wire (2) to the blue wire (3) or leave open.	<p>Through-beam receivers, retroreflective models, diffuse reflective models</p>
	Dark ON		Connect the pink wire (2) to the brown wire (1).	
<p>Through-beam Emitter</p>				
E3F□-LS6	Light ON		Connect the pink wire (2) to the blue wire (3) or leave open.	
	Dark ON		Connect the pink wire (2) to the brown wire (1).	

Connector Pin Arrangement

- M12 Pre-wired Connector (-M1J)
- M12 Connector Pin Arrangement



Connectors (Sensor I/O connectors)

M12 4-wire Connectors

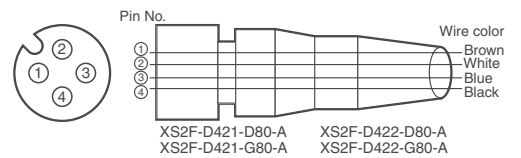

Classification	Wire color	Connector pin No.	Application
DC	Brown	①	Power supply (+V)
	White	②	Operation selection
	Blue	③	Power supply (0 V)
	Black	④	Output

Dimensions

Note: All units are in millimeters unless otherwise stated.

E3FZ-Series

E3FZ-T□
Emitter

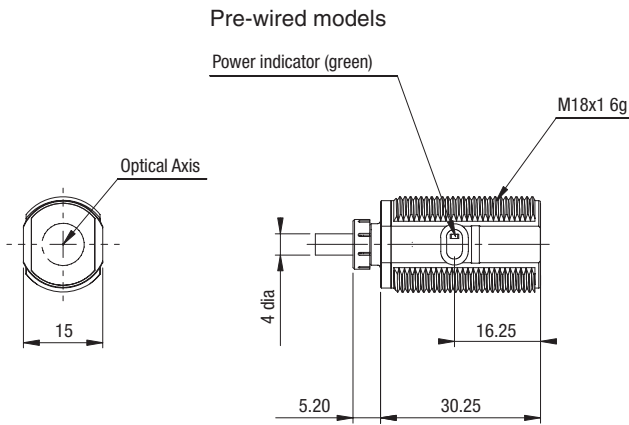

Connector models

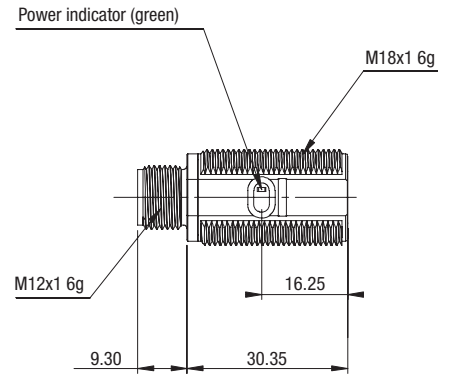

E3FZ-T□
Receiver

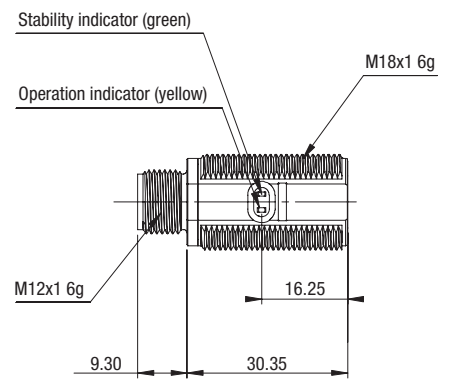
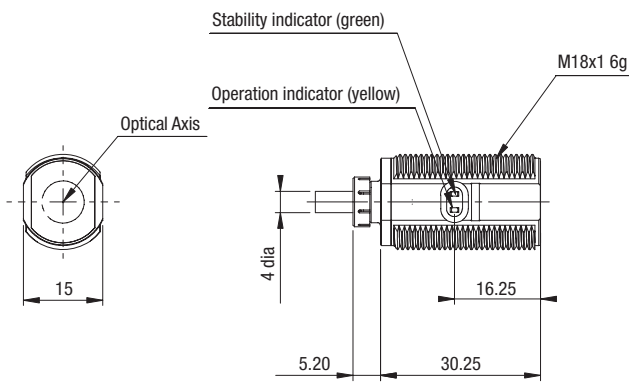

E3FZ-R□
E3FZ-LS□

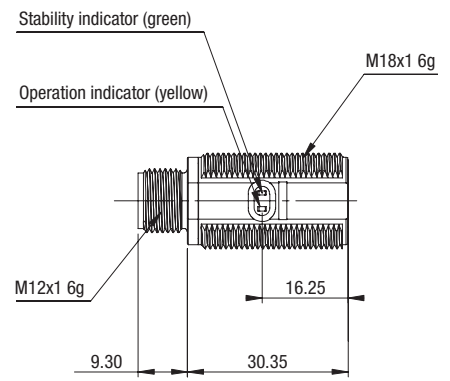
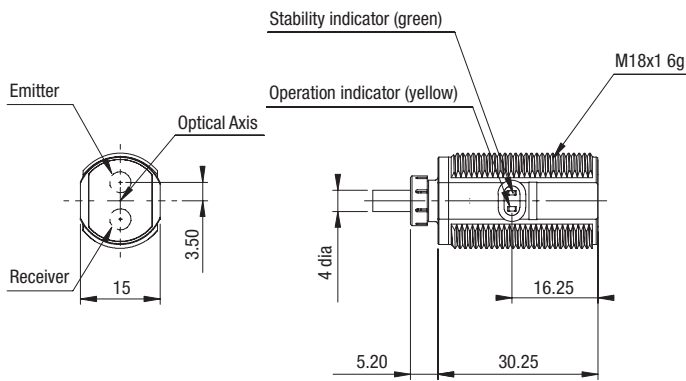

E3FZ-D□

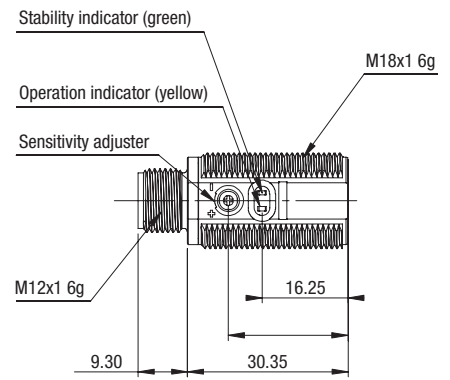
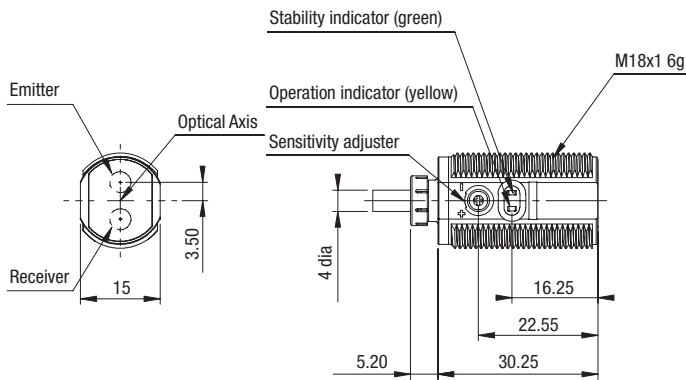

E3FR Series

E3FR-T□1H 2M

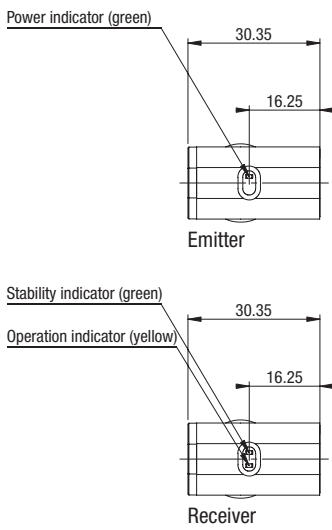

Pre-wired models

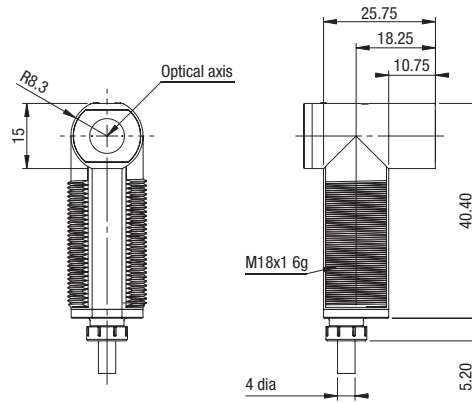

Connector models

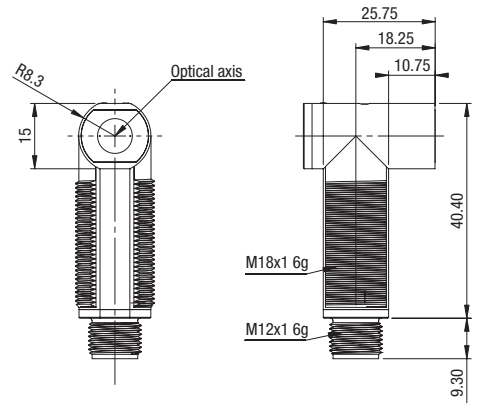

E3FR-R□1H 2M

E3FR-LS□1H 2M

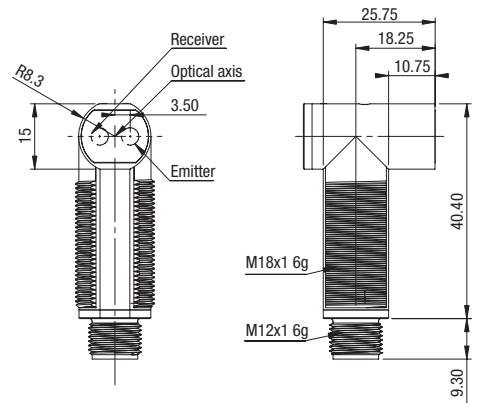
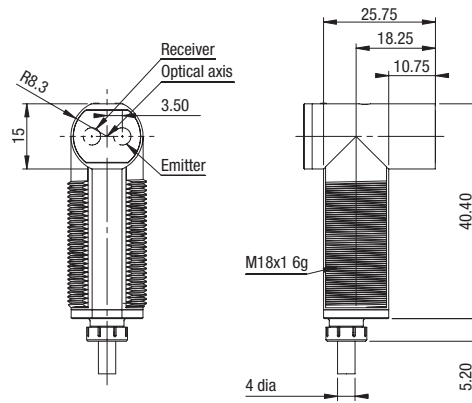
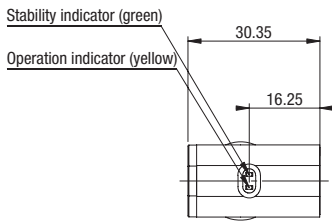

E3FR-D□2 2M

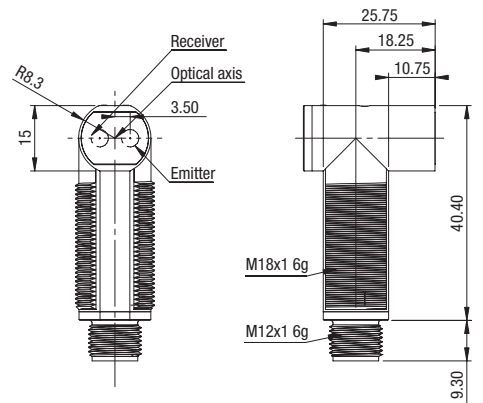
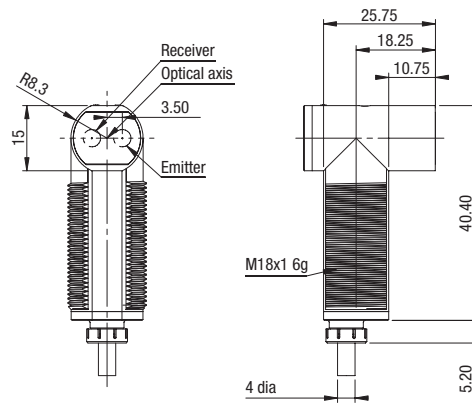
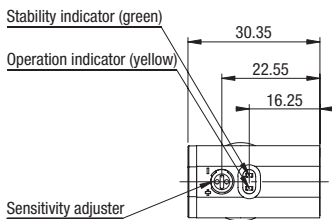

Accessories

E39-R1S



Material:
ABS base,
acrylic surface

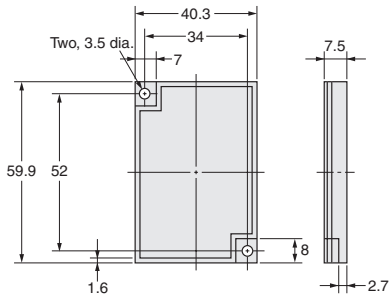

E38-R49



Material:
ABS base,
acrylic surface

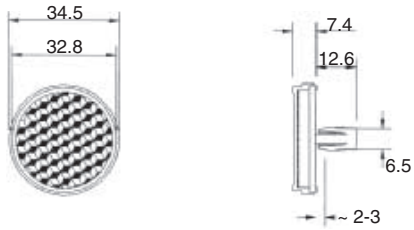

E39-EL8



Material:
stainless steel

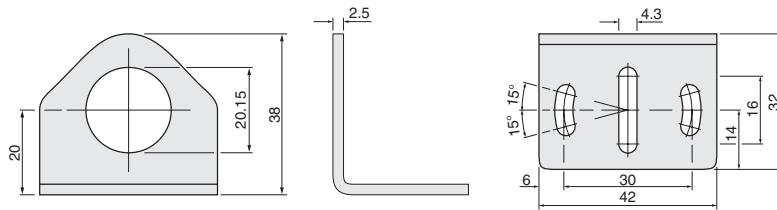

E39-EL9
(can be attached
to dia 12 mm
mounting rod)



Material:
stainless steel

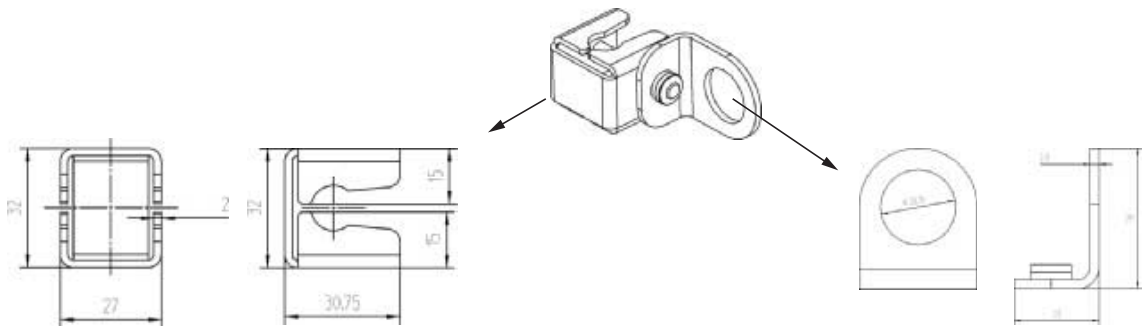

Snap mount tool



Material:
ABS

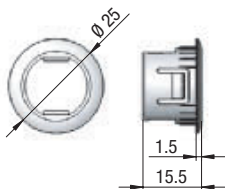

Safety precautions

 Warning

This product is not designed or rated for directly or indirectly ensuring safety of persons. Do not use it for such a purpose.



 Caution

Do not use the product with voltage in excess of the rated voltage. Excess voltage may result in malfunction or fire.



Never use the product with an AC power supply. Otherwise, explosion may result.



When cleaning the product, do not apply a high-pressure spray of water to one part of the product. Otherwise, parts may become damaged and the degree of protection may be degraded.



High-temperature environments may result in burn injury.



Precautions for Safe Use

The following precautions must be observed to ensure safe operation of the Sensor.

Operating Environment

Do not use the Sensor in an environment where explosive or flammable gas is present.

Connecting Connectors

Be sure to hold the connector cover when inserting or removing the connector. Be sure to tighten the connector lock by hand; do not use pliers or other tools. If the tightening is insufficient, the degree of protection will not be maintained and the Sensor may become loose due to vibration. The appropriate tightening torque is 0.39 to 0.49 N·m for M12 connectors.

Load

Do not use a load that exceeds the rated load.

Rotation Torque for Sensitivity Adjustment

Adjust with a torque of 0.05 N·m or less.

Environments with Cleaners and Disinfectants (e.g., Food Processing Lines)

Do not use the Sensor in environments subject to cleaners and disinfectants. They may reduce the degree of protection.

Modifications

Do not attempt to disassemble, repair, or modify the Sensor.

Outdoor Use

Do not use the Sensor in locations subject to direct sunlight.

Cleaning

Do not use thinner, alcohol, or other organic solvents. Otherwise, the optical properties and degree of protection may be degraded.

Surface Temperature

Burn injury may occur. The Sensor surface temperature rises depending on application conditions, such as the surrounding temperature and the power supply voltage. Use caution when operating or washing the Sensor.

Precautions for Correct Use

Do not use the Sensor in any atmosphere or environment that exceeds the ratings.

Do not install the Sensor in the following locations.

- (1) Locations subject to direct sunlight
- (2) Locations subject to condensation due to high humidity
- (3) Locations subject to corrosive gas
- (4) Locations where the Sensor may receive direct vibration or shock

Connecting and Mounting

- (1) The maximum power supply voltage is 30 VDC. Before turning the power ON, make sure that the power supply voltage does not exceed the maximum voltage.
- (2) Laying Sensor wiring in the same conduit or duct as high-voltage wires or power lines may result in malfunction or damage due to induction. As a general rule, wire the Sensor in a separate conduit or use shielded cable.
- (3) Use an extension cable with a minimum thickness of 0.3 mm² and less than 100 m long.
- (4) Do not pull on the cable with excessive force.
- (5) Pounding the Photoelectric Sensor with a hammer or other tool during mounting will impair water resistance.
- (6) Mount the Sensor either using the bracket (sold separately) or on a flat surface.
- (7) Be sure to turn OFF the power supply before inserting or removing the connector.

Cleaning

Never use thinner or other solvents. Otherwise, the Sensor surface may be dissolved.

Power Supply

If a commercial switching regulator is used, ground the FG (frame ground) terminal.

Power Supply Reset Time

The Sensor will be able to detect objects 100 ms after the power supply is tuned ON. Start using the Sensor 100 ms or more after turning ON the power supply. If the load and the Sensor are connected to separate power supplies, be sure to turn ON the Sensor first.

Turning OFF the Power Supply

Output pulses may be generated even when the power supply is OFF. Therefore, it is recommended to first turn OFF the power supply for the load or the load line.

Load Short-circuit Protection

This Sensor is equipped with load short-circuit protection, but be sure to not short circuit the load. Be sure to not use an output current flow that exceeds the rated current. If a load short circuit occurs, the output will turn OFF, so check the wiring before turning ON the power supply again. The short-circuit protection circuit will be reset. The load short-circuit protection will operate when the current flow reaches 1.8 times the rated load current. When using a capacitive load, use an inrush current of 1.8 times the rated load current or higher.

Water Resistance

Do not use the Sensor in water, rainfall, or outdoors.

WARRANTY

OMRON's exclusive warranty is that the products are free from defects in materials and workmanship for a period of one year (or other period if specified) from date of sale by OMRON.

OMRON MAKES NO WARRANTY OR REPRESENTATION, EXPRESS OR IMPLIED, REGARDING NON-INFRINGEMENT, MERCHANTABILITY, OR FITNESS FOR PARTICULAR PURPOSE OF THE PRODUCTS. ANY BUYER OR USER ACKNOWLEDGES THAT THE BUYER OR USER ALONE HAS DETERMINED THAT THE PRODUCTS WILL SUITABLY MEET THE REQUIREMENTS OF THEIR INTENDED USE. OMRON DISCLAIMS ALL OTHER WARRANTIES, EXPRESS OR IMPLIED.

LIMITATIONS OF LIABILITY

OMRON SHALL NOT BE RESPONSIBLE FOR SPECIAL, INDIRECT, OR CONSEQUENTIAL DAMAGES, LOSS OF PROFITS OR COMMERCIAL LOSS IN ANY WAY CONNECTED WITH THE PRODUCTS, WHETHER SUCH CLAIM IS BASED ON CONTRACT, WARRANTY, NEGLIGENCE, OR STRICT LIABILITY.

In no event shall responsibility of OMRON for any act exceed the individual price of the product on which liability is asserted.

IN NO EVENT SHALL OMRON BE RESPONSIBLE FOR WARRANTY, REPAIR, OR OTHER CLAIMS REGARDING THE PRODUCTS UNLESS OMRON'S ANALYSIS CONFIRMS THAT THE PRODUCTS WERE PROPERLY HANDLED, STORED, INSTALLED, AND MAINTAINED AND NOT SUBJECT TO CONTAMINATION, ABUSE, MISUSE, OR INAPPROPRIATE MODIFICATION OR REPAIR.

SUITABILITY FOR USE

THE PRODUCTS CONTAINED IN THIS DOCUMENT ARE NOT SAFETY RATED. THEY ARE NOT DESIGNED OR RATED FOR ENSURING SAFETY OF PERSONS, AND SHOULD NOT BE RELIED UPON AS A SAFETY COMPONENT OR PROTECTIVE DEVICE FOR SUCH PURPOSES. Please refer to separate catalogs for OMRON's safety rated products.

OMRON shall not be responsible for conformity with any standards, codes, or regulations that apply to the combination of products in the customer's application or use of the product.

At the customer's request, OMRON will provide applicable third party certification documents identifying ratings and limitations of use that apply to the products. This information by itself is not sufficient for a complete determination of the suitability of the products in combination with the end product, machine, system, or other application or use.

The following are some examples of applications for which particular attention must be given. This is not intended to be an exhaustive list of all possible uses of the products, nor is it intended to imply that the uses listed may be suitable for the products:

- Outdoor use, uses involving potential chemical contamination or electrical interference, or conditions or uses not described in this document.
- Nuclear energy control systems, combustion systems, railroad systems, aviation systems, medical equipment, amusement machines, vehicles, safety equipment, and installations subject to separate industry or government regulations.
- Systems, machines, and equipment that could present a risk to life or property.

Please know and observe all prohibitions of use applicable to the products.

NEVER USE THE PRODUCTS FOR AN APPLICATION INVOLVING SERIOUS RISK TO LIFE OR PROPERTY WITHOUT ENSURING THAT THE SYSTEM AS A WHOLE HAS BEEN DESIGNED TO ADDRESS THE RISKS, AND THAT THE OMRON PRODUCT IS PROPERLY RATED AND INSTALLED FOR THE INTENDED USE WITHIN THE OVERALL EQUIPMENT OR SYSTEM.

PERFORMANCE DATA

Performance data given in this document is provided as a guide for the user in determining suitability and does not constitute a warranty. It may represent the result of OMRON's test conditions, and the users must correlate it to actual application requirements. Actual performance is subject to the OMRON Warranty and Limitations of Liability.

CHANGE IN SPECIFICATIONS

Product specifications and accessories may be changed at any time based on improvements and other reasons.

It is our practice to change model numbers when published ratings or features are changed, or when significant construction changes are made. However, some specifications of the product may be changed without any notice. When in doubt, special model numbers may be assigned to fix or establish key specifications for your application on your request. Please consult with your OMRON representative at any time to confirm actual specifications of purchased products.

DIMENSIONS AND WEIGHTS

Dimensions and weights are nominal and are not to be used for manufacturing purposes, even when tolerances are shown.

ERRORS AND OMISSIONS

The information in this document has been carefully checked and is believed to be accurate; however, no responsibility is assumed for clerical, typographical, or proofreading errors, or omissions.

PROGRAMMABLE PRODUCTS

OMRON shall not be responsible for the user's programming of a programmable product, or any consequence thereof.

Cat. No. E55E-EN-01

In the interest of product improvement, specifications are subject to change without notice.

OMRON EUROPE B.V.

Wegalaan 67-69,
 NL-2132 JD, Hoofddorp,
 The Netherlands
 Phone: +31 23 568 13 00
 Fax: +31 23 568 13 88
 www.industrial.omron.eu