



Chipsmall Limited consists of a professional team with an average of over 10 year of expertise in the distribution of electronic components. Based in Hongkong, we have already established firm and mutual-benefit business relationships with customers from,Europe,America and south Asia,supplying obsolete and hard-to-find components to meet their specific needs.

With the principle of "Quality Parts,Customers Priority,Honest Operation,and Considerate Service",our business mainly focus on the distribution of electronic components. Line cards we deal with include Microchip,ALPS,ROHM,Xilinx,Pulse,ON,Everlight and Freescale. Main products comprise IC,Modules,Potentiometer,IC Socket,Relay,Connector.Our parts cover such applications as commercial,industrial, and automotives areas.

We are looking forward to setting up business relationship with you and hope to provide you with the best service and solution. Let us make a better world for our industry!



## Contact us

Tel: +86-755-8981 8866 Fax: +86-755-8427 6832

Email & Skype: info@chipsmall.com Web: www.chipsmall.com

Address: A1208, Overseas Decoration Building, #122 Zhenhua RD., Futian, Shenzhen, China



# E3Z-G

## Photoelectric Sensor with Grooved Design and Easy Settings



- Groove-type Sensor with groove width of 25 mm.
- Models are available with one or two light axes.
- Models are available with M8 pre-wired connectors.



Be sure to read *Safety Precautions* on page 4.

For the most recent information on models that have been certified for safety standards, refer to your OMRON website.

## Ordering Information

**Sensors** (Refer to *Dimensions* on page 4.)

Infrared light

Sensing method	Appearance	Connection method	Sensing distance	No. of optical axes	Model	
					NPN output	PNP output
Through-beam		Pre-wired (2 m)		1	E3Z-G61 2M *1 *2	E3Z-G81 2M *1 *2
		Pre-wired Connector (M8, 4 pins)			E3Z-G61-M3J 0.3M	E3Z-G81-M3J 0.3M
		Pre-wired (2 m)		2	E3Z-G62 2M *1	E3Z-G82 2M *1
		Pre-wired Connector (M8, 4 pins)			E3Z-G62-M3J 0.3M	E3Z-G82-M3J 0.3M

\*1. M12 Standard Pre-wired Connector Models are also available. When ordering, add "-M1J 0.3M" to the end of the model number (e.g., E3Z-G61-M1J 0.3M). The cable is 0.3 m long.

\*2. M12 Pre-wired Smartclick Connector Models are also available. When ordering, add "-M1TJ 0.3M" to the end of the model number (e.g., E3Z-G61-M1TJ 0.3M). The cable is 0.3 m long.

## Accessories (Order Separately)

### Sensor I/O Connectors (Sockets on One Cable End)

(Models with Pre-wired Connectors: A Connector is not provided with the Sensor. Be sure to order a Connector separately.) (Refer to *Dimensions* on XS3.)

Cable specification	Appearance	Type of cable	Model
Standard cable		2 m	XS3F-M421-402-A
		5 m	XS3F-M421-405-A
		2 m	XS3F-M422-402-A
		5 m	XS3F-M422-405-A
Vibration-proof robot cable		2 m	XS3F-M421-402-R
		5 m	XS3F-M421-405-R
		2 m	XS3F-M422-402-R
		5 m	XS3F-M422-405-R

Note: Refer to *Introduction to Sensor I/O Connectors/Sensor Controllers* for details.

### Protective Bracket

A Protective Bracket is not provided with the Sensor. Order a Protective Bracket separately if required. (Refer to *Dimensions* on E39-L/E39-S/E39-R)

Appearance	Model	Applicable model
	E39-L149	E3Z-G

## Ratings and Specifications

Number of optical axes		1	2
Item	Model	E3Z-G61/E3Z-G61-M3J	E3Z-G62/E3Z-G62-M3J
		E3Z-G81/E3Z-G81-M3J	E3Z-G82/E3Z-G82-M3J
Sensing distance (distance between arms of groove)		25 mm	
Standard sensing object		Opaque, 1.5-mm dia. min.	
Light source (wavelength)		Infrared LED (940 nm)	
Power supply voltage		12 to 24 VDC±10%, ripple (p-p): 10% max.	
Current consumption		25 mA max.	40 mA max.
Control output		Load power supply voltage: 26.4 VDC max. Load current: 100 mA max. (Residual voltage: 1 V max.) Open collector output (NPN or PNP depending on model) Light-ON/Dark-ON selectable	
Protection circuits		Reversed power supply polarity protection, Output short-circuit protection, and Mutual interference prevention	
Response time		Operate or reset: 1 ms max.	
Ambient illumination (Receiver side)		Incandescent lamp: 3,000 lx max. Sunlight: 10,000 lx max.	
Ambient temperature range		Operating: -25 to 55°C, Storage: -40 to 70°C (with no icing or condensation)	
Ambient humidity range		Operating: 35% to 85%, Storage: 35% to 95% (with no condensation)	
Insulation resistance		20 MΩ min. at 500 VDC between lead wires and case	
Dielectric strength		1,000 VAC, 50/60 Hz for 1 min between lead wires and case	
Vibration resistance		Destruction: 10 to 55 Hz, 1.5-mm double amplitude for 2 hours each in X, Y, and Z directions	
Shock resistance		Destruction: 500 m/s <sup>2</sup> 3 times each in X, Y, and Z directions	
Degree of protection		IP64 (IEC 60529)	
Connection method		Pre-wired cable (standard length: 2 m and 0.5 m)/Pre-wired Connector (standard length: 300 mm)	
Indicator		Operation indicator (orange)	
Weight (packed state)	Pre-wired (with 2-m cable)	Approx. 65 g	
	Pre-wired Connectors	Approx. 30 g	
Material	Case	ABS (Acrylonitril Butadiene Styrene)	
Accessories		Instruction manual	

I/O Circuit Diagrams

NPN Output

No. of optical axes/model	Operation mode	Timing charts	Operation selector	Output circuit
1 axis E3Z-G61 E3Z-G61-M3J	Light-ON	<p>Incident light ON, No incident light OFF, Operation indicator (orange) ON, Control output ON, Output transistor OFF, Load Operate (e.g., relay) Reset. (Between brown ① and black ④ leads)</p>	L side (LIGHT ON)	<p>Connector Pin Arrangement</p> <p>Pin 2 is not used.</p>
	Dark-ON	<p>Incident light OFF, No incident light ON, Operation indicator (orange) OFF, Control output ON, Output transistor OFF, Load Operate (e.g., relay) Reset. (Between brown ① and black ④ leads)</p>	D side (DARK ON)	<p>Connector Pin Arrangement</p> <p>Pin 2 is not used.</p>
2 axes E3Z-G62 E3Z-G62-M3J	Light-ON	<p>Incident light ON, No incident light OFF, Operation indicator (orange) ON, Control output ON, Output transistor OFF, Load Operate (e.g., relay) Reset. (Between brown ① and black ④ (white ②) leads)</p>	L side (LIGHT ON)	<p>Connector Pin Arrangement</p> <p>Pin 2 is not used.</p>
	Dark-ON	<p>Incident light OFF, No incident light ON, Operation indicator (orange) OFF, Control output ON, Output transistor OFF, Load Operate (e.g., relay) Reset. (Between brown ① and black ④ (white ②) leads)</p>	D side (DARK ON)	<p>Connector Pin Arrangement</p> <p>Pin 2 is not used.</p>

PNP Output

No. of optical axes/model	Operation mode	Timing charts	Operation selector	Output circuit
1 axis E3Z-G81 E3Z-G81-M3J	Light-ON	<p>Incident light ON, No incident light OFF, Operation indicator (orange) OFF, Control output ON, Output transistor OFF, Load Operate (e.g., relay) Reset. (Between blue ③ and black ④ leads)</p>	L side (LIGHT ON)	<p>Connector Pin Arrangement</p> <p>Pin 2 is not used.</p>
	Dark-ON	<p>Incident light OFF, No incident light ON, Operation indicator (orange) ON, Control output ON, Output transistor OFF, Load Operate (e.g., relay) Reset. (Between blue ③ and black ④ leads)</p>	D side (DARK ON)	<p>Connector Pin Arrangement</p> <p>Pin 2 is not used.</p>
2 axes E3Z-G82 E3Z-G82-M3J	Light-ON	<p>Incident light ON, No incident light OFF, Operation indicator (orange) OFF, Control output ON, Output transistor OFF, Load Operate (e.g., relay) Reset. (Between blue ③ and black ④ (white ②) leads)</p>	L side (LIGHT ON)	<p>Connector Pin Arrangement</p> <p>Pin 2 is not used.</p>
	Dark-ON	<p>Incident light OFF, No incident light ON, Operation indicator (orange) ON, Control output ON, Output transistor OFF, Load Operate (e.g., relay) Reset. (Between blue ③ and black ④ (white ②) leads)</p>	D side (DARK ON)	<p>Connector Pin Arrangement</p> <p>Pin 2 is not used.</p>

## Plugs (Sensor I/O Connectors)

### M8 connector

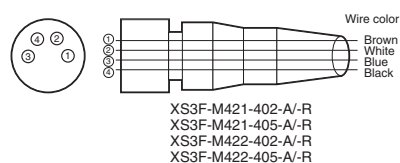

### Pin arrangement

Classification	Wire color	Connector pin No.	Application	
			1-axis models	2-axis models
DC	Brown	1	Power supply (+V)	
	White	2	---	Output 2 (S2)
	Blue	3	Power supply (0 V)	
	Black	4	Output	Output 1 (S1)

Note: Pin 2 of 1-axis models is not used.

## Safety Precautions

### Refer to *Warranty and Limitations of Liability*.

#### ⚠ WARNING

This product is not designed or rated for ensuring safety of persons either directly or indirectly. Do not use it for such purposes.



#### Precautions for Correct Use

- Do not use the product in atmospheres or environments that exceed product ratings.
- The degree of protection for this Product is IP64 (IEC). The degree of protection for other models in the E3Z Series is IP67.

## Dimensions

(Unit: mm)

Tolerance class IT16 applies to dimensions in this datasheet unless otherwise specified.

## Sensors

### E3Z-G61

### E3Z-G62

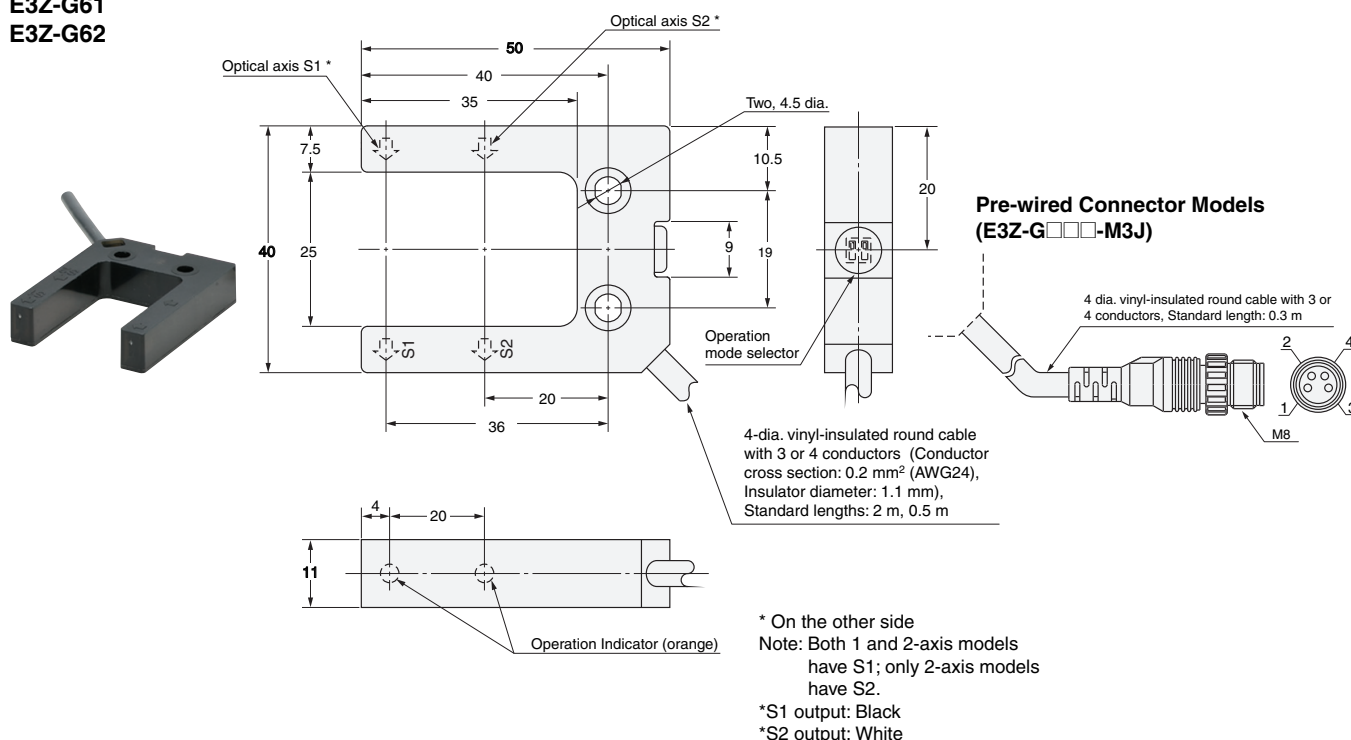

## Accessories (Order Separately)

### Mounting Brackets

Refer to E39-L for details.

### Sensor I/O Connectors

Refer to XS3F for details.

## Terms and Conditions Agreement

### Read and understand this catalog.

Please read and understand this catalog before purchasing the products. Please consult your OMRON representative if you have any questions or comments.

### Warranties.

(a) Exclusive Warranty. Omron's exclusive warranty is that the Products will be free from defects in materials and workmanship for a period of twelve months from the date of sale by Omron (or such other period expressed in writing by Omron). Omron disclaims all other warranties, express or implied.

(b) Limitations. OMRON MAKES NO WARRANTY OR REPRESENTATION, EXPRESS OR IMPLIED, ABOUT NON-INFRINGEMENT, MERCHANTABILITY OR FITNESS FOR A PARTICULAR PURPOSE OF THE PRODUCTS. BUYER ACKNOWLEDGES THAT IT ALONE HAS DETERMINED THAT THE PRODUCTS WILL SUITABLY MEET THE REQUIREMENTS OF THEIR INTENDED USE.

Omron further disclaims all warranties and responsibility of any type for claims or expenses based on infringement by the Products or otherwise of any intellectual property right. (c) Buyer Remedy. Omron's sole obligation hereunder shall be, at Omron's election, to (i) replace (in the form originally shipped with Buyer responsible for labor charges for removal or replacement thereof) the non-complying Product, (ii) repair the non-complying Product, or (iii) repay or credit Buyer an amount equal to the purchase price of the non-complying Product; provided that in no event shall Omron be responsible for warranty, repair, indemnity or any other claims or expenses regarding the Products unless Omron's analysis confirms that the Products were properly handled, stored, installed and maintained and not subject to contamination, abuse, misuse or inappropriate modification. Return of any Products by Buyer must be approved in writing by Omron before shipment. Omron Companies shall not be liable for the suitability or unsuitability or the results from the use of Products in combination with any electrical or electronic components, circuits, system assemblies or any other materials or substances or environments. Any advice, recommendations or information given orally or in writing, are not to be construed as an amendment or addition to the above warranty.

See <http://www.omron.com/global/> or contact your Omron representative for published information.

### Limitation on Liability: Etc.

OMRON COMPANIES SHALL NOT BE LIABLE FOR SPECIAL, INDIRECT, INCIDENTAL, OR CONSEQUENTIAL DAMAGES, LOSS OF PROFITS OR PRODUCTION OR COMMERCIAL LOSS IN ANY WAY CONNECTED WITH THE PRODUCTS, WHETHER SUCH CLAIM IS BASED IN CONTRACT, WARRANTY, NEGLIGENCE OR STRICT LIABILITY.

Further, in no event shall liability of Omron Companies exceed the individual price of the Product on which liability is asserted.

### Suitability of Use.

Omron Companies shall not be responsible for conformity with any standards, codes or regulations which apply to the combination of the Product in the Buyer's application or use of the Product. At Buyer's request, Omron will provide applicable third party certification documents identifying ratings and limitations of use which apply to the Product. This information by itself is not sufficient for a complete determination of the suitability of the Product in combination with the end product, machine, system, or other application or use. Buyer shall be solely responsible for determining appropriateness of the particular Product with respect to Buyer's application, product or system. Buyer shall take application responsibility in all cases.

NEVER USE THE PRODUCT FOR AN APPLICATION INVOLVING SERIOUS RISK TO LIFE OR PROPERTY OR IN LARGE QUANTITIES WITHOUT ENSURING THAT THE SYSTEM AS A WHOLE HAS BEEN DESIGNED TO ADDRESS THE RISKS, AND THAT THE OMRON PRODUCT(S) IS PROPERLY RATED AND INSTALLED FOR THE INTENDED USE WITHIN THE OVERALL EQUIPMENT OR SYSTEM.

### Programmable Products.

Omron Companies shall not be responsible for the user's programming of a programmable Product, or any consequence thereof.

### Performance Data.

Data presented in Omron Company websites, catalogs and other materials is provided as a guide for the user in determining suitability and does not constitute a warranty. It may represent the result of Omron's test conditions, and the user must correlate it to actual application requirements. Actual performance is subject to the Omron's Warranty and Limitations of Liability.

### Change in Specifications.

Product specifications and accessories may be changed at any time based on improvements and other reasons. It is our practice to change part numbers when published ratings or features are changed, or when significant construction changes are made. However, some specifications of the Product may be changed without any notice. When in doubt, special part numbers may be assigned to fix or establish key specifications for your application. Please consult with your Omron's representative at any time to confirm actual specifications of purchased Product.

### Errors and Omissions.

Information presented by Omron Companies has been checked and is believed to be accurate; however, no responsibility is assumed for clerical, typographical or proofreading errors or omissions.