



Chipsmall Limited consists of a professional team with an average of over 10 year of expertise in the distribution of electronic components. Based in Hongkong, we have already established firm and mutual-benefit business relationships with customers from,Europe,America and south Asia,supplying obsolete and hard-to-find components to meet their specific needs.

With the principle of “Quality Parts,Customers Priority,Honest Operation,and Considerate Service”,our business mainly focus on the distribution of electronic components. Line cards we deal with include Microchip,ALPS,ROHM,Xilinx,Pulse,ON,Everlight and Freescale. Main products comprise IC,Modules,Potentiometer,IC Socket,Relay,Connector.Our parts cover such applications as commercial,industrial, and automotives areas.

We are looking forward to setting up business relationship with you and hope to provide you with the best service and solution. Let us make a better world for our industry!



Contact us

Tel: +86-755-8981 8866 Fax: +86-755-8427 6832

Email & Skype: info@chipsmall.com Web: www.chipsmall.com

Address: A1208, Overseas Decoration Building, #122 Zhenhua RD., Futian, Shenzhen, China



REVISION RECORD				
REV	ECO	DESCRIPTION	DRFT	CHKD

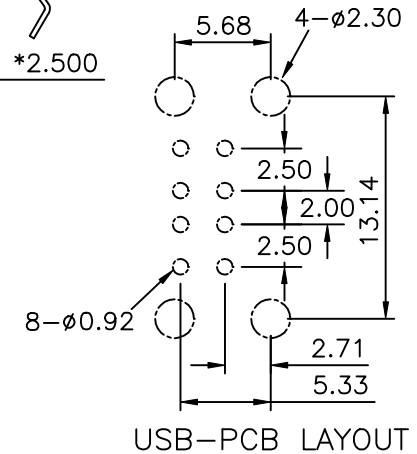
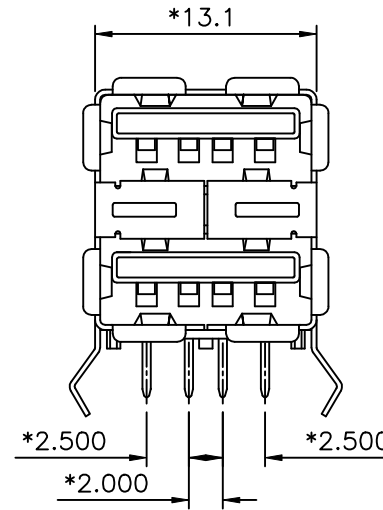
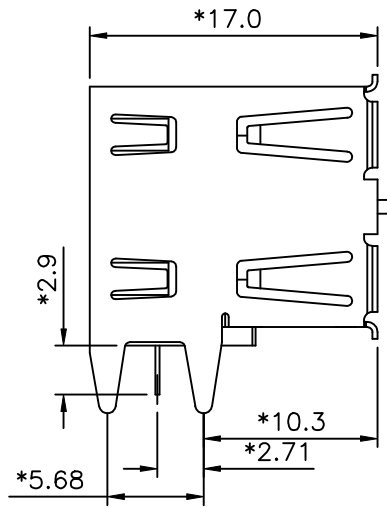
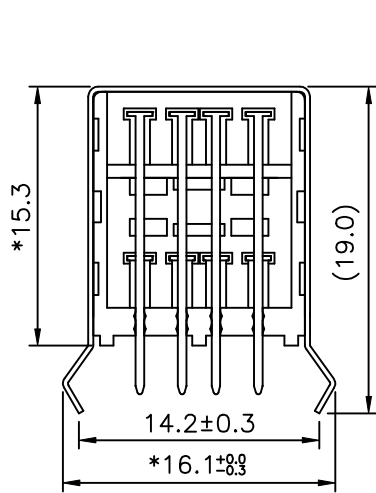

NOTES:

- MATERIAL:
 TERMINAL-C5191 PHOSPHOR BRONZE HARD. (t=0.25mm)
 SHIELD-(t=0.30mm)COPPER ALLOY OR PHOSPHOR BRONZE.
 HOUSING-PBT+ 30% G.F. UL94V-0/COLOR:WHITE & BLACK.
- PLATING:
 CONTACT-AREA-SELECTIVE PLATING. ON THE MATING END.
 TAILS-150u" TIN-LEAD MIN OVER 50u" NICKEL.
 SHIELD-120u" TIN-LEAD MIN OVER 50u" NICKEL.
 OR 100u"~120u" NI OVER 40u" Cu.
- TOLERANCE: ±0.3mm,±3'.
- GAP. 0.25mm (Max.)
- ELECTRICAL:
 VOLTAGE RATING: 30 VAC RMS.
 CURRENT RATING: 1.0 AMP
 CONTACT RESISTANCE: 30 MILLIOHMS MAX
 INSULATION RESISTANCE: 1000 MEGOHMS MIN @500 VDC
 DIELECTRIC STRENGTH: 750 VAC RMS 60 HZ, 1 MIN
 OPERATING LIFE: 1500 CYCLES MIN
 MATING FORCE: 3.5 KGS MAX
 UNMATING FORE: 1 KGS MIN
 STORAGE: -40° C TO +85° C
 OPERATION: 0° C TO 70° C
 CAPACITANCE: 2 PF MAX 1KHZ
 WAVE SOLDERING TEMPERATURE 230-250(3~5 SECONDS)
- Lead_FreeP/N: E8144-1XXX2X-L

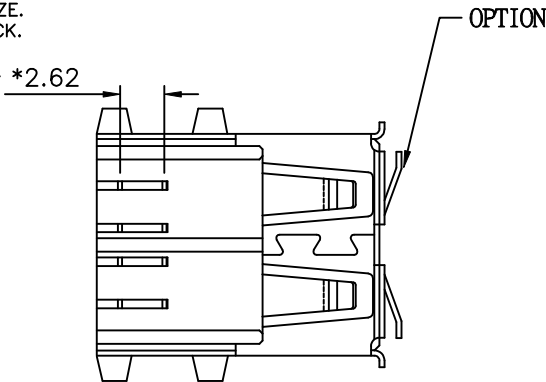

Shield FS0803(Made in MaxTop)

- 0-COPPER ALLOY
 - 1-PHOSPHOR BRONZE
 - 1-Au3u"
 - 3-Au15u"
 - 5-Au50u"
 - 2-Au6u"
 - 4-Au30u"
 - 7-Pd30u"
 - 0-A06-0080-L(BLACK)
 - 3-A06-0010-L(WHITE)
 - 7-A06-2230-L(YELLOW)
- SHIELD TYPE:
- 1-NICKEL
 - 2-TIN LEAD
 - A-NICKEL (NO FRONT TAP)
 - B-TIN LEAD (NO FRONT TAP)

SHIELD TOOL:FS0803
 HS'G TOOL:FR2711

DETAILED LISTS	MM (INCH)	DFTO Linger	DATE 3/28/05'
	TOLERANCES EXCEPT AS NOTED	CHKDSIX	DATE2005/3/30
		MFO	DATE
		APPVLPETER	DATE2005/3/30
	MM		
	.0 ±0.20	±	
	.00 ±0.15	±	
	.000 ±0.075	±	
	ANGLES ±	QT'Y :	
	THIRD ANGLE PROJECTION	FINISH :	
		SCALE : 1:1	

FULL RISE ELECTRONIC CO., LTD	
TITLE USB A TYPE STACK	
DRAWING NO. GE813013_LC	SIZE A3
/PART NO. SEE NOTE	REV 0 3/28/05'
DO NOT SCALE DRAWING	SHEET 1 OF 1