



Chipsmall Limited consists of a professional team with an average of over 10 year of expertise in the distribution of electronic components. Based in Hongkong, we have already established firm and mutual-benefit business relationships with customers from,Europe,America and south Asia,supplying obsolete and hard-to-find components to meet their specific needs.

With the principle of “Quality Parts,Customers Priority,Honest Operation,and Considerate Service”,our business mainly focus on the distribution of electronic components. Line cards we deal with include Microchip,ALPS,ROHM,Xilinx,Pulse,ON,Everlight and Freescale. Main products comprise IC,Modules,Potentiometer,IC Socket,Relay,Connector.Our parts cover such applications as commercial,industrial, and automotives areas.

We are looking forward to setting up business relationship with you and hope to provide you with the best service and solution. Let us make a better world for our industry!



Contact us

Tel: +86-755-8981 8866 Fax: +86-755-8427 6832

Email & Skype: info@chipsmall.com Web: www.chipsmall.com

Address: A1208, Overseas Decoration Building, #122 Zhenhua RD., Futian, Shenzhen, China



E97S USER'S GUIDE

Overview

The E97S board is designed for rapid evaluation and prototyping of the QT9701B2 IC in capacitance-based detection systems. It includes all the circuitry required to make a fully functioning sensor system. Using the QT9701B2 QProx IC, this board has a full-duplex serial interface that allows connection to a PC for function control and data viewing or logging. This board is fully compatible with QTWinview software.

For more detailed information about this product refer to the QT9701B2 datasheet.

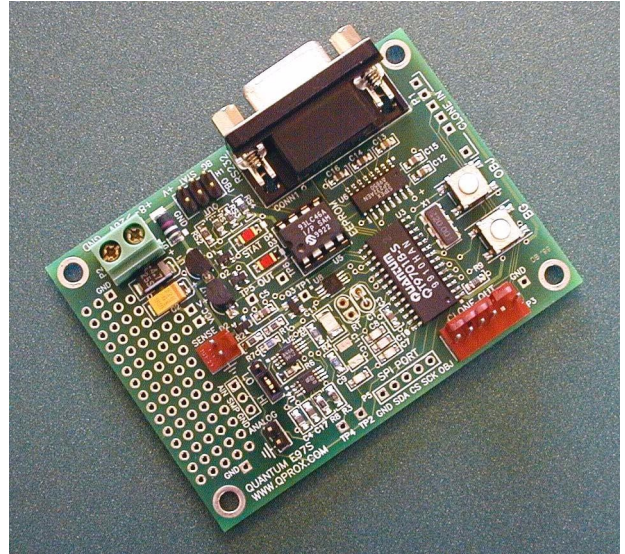

Fast Start

To begin using the board right away:

1. Connect a switchable source of +8 to +20VDC to the screw terminal block. This may be a 9V alkaline battery or a bench supply. Don't turn on the power just yet.
2. Connect the RS232 serial connector to a PC using a 'straight-through' extender type DB9 serial cable.
3. Plug in the thin coax cable to the connector labeled 'SIGNAL' on the board; connect the center conductor of the other end of this cable to a piece of metal foil or other floating metal object.
4. Run QTWinview on the PC. Click on FILE | LOAD GRID and open the file 'QT9701B2.qdf'.
5. Click on COMM | SETUP and make sure the PC serial port matches the one you are using. Make sure the Baud Rate is set at 9600.
6. Apply power to the board. One or both LEDs will illuminate or flash.
7. Click on 'GO ONLINE' at the bottom of the QTWinView window.
8. Click on 'GRAB CURRENT' at the bottom of the QTWinView window. Cells in the Setup table will highlight to reflect the settings loaded in the E97S.
9. Click on 'POLL QPROX' at the bottom of the QTWinView window to view the actual signals coming from the board.

If the board will not communicate with the PC, check the Baud rate and Comm port settings, your cable connections, and the power to the E97S. If the board will still not communicate, see the **Trouble Shooting** section of this document.

As your hand approaches the electrode, the Signal level will rise to reflect the increase in capacitance.

Schematic

A schematic of the E97S is found at the end of this Operation Guide. Files in DXF, PCAD or Orcad are available from Quantum free on request to techsupport@qprox.com.

Layouts

PCB Layout printouts are found at the end of this Operation Guide. Files in Gerber, GCPrevue, PCAD, or DXF formats are available from Quantum free on request to techsupport@qprox.com and you are encouraged to make use of them.

Board Details

Power Connector

This screw terminal strip can be used to power the board. The voltage should be between +8 and +20 volts DC. Power should be free from switching noise and short-term fluctuations for best performance.

Main Connector

(Located between RS232 and Power strip) This connector contains the BG and OBJ signal lines to permit external hardware calibration control, plus the Out and Stat lines. It also has a connector for V+ to allow for external power over the same header.

RS232 Connector

This connector provides bi-directional communications between the E97S and an external host, like a PC or a microcontroller. It allows full control over the device including calibration and Setups. It also allows for real-time downloading of signal and reference information at up to 115K Baud.

A substantial section on QT9701B2 serial operation and protocol is included in Section 3 of the QT9701B2 datasheet that is not repeated in this operation guide.

Sense Connector

This 2-pin header provides the interface to the sensing electrode. One pin is board ground and should be connected to the shield of the cable (if shielded). The other is the signal line which should be directly connected to the sense electrode.

Sampled Analog Header

These 3 pads labeled 'AIN SMP GND' can be used in conjunction with a sample and hold circuit to create a 'raw' analog signal that is unprocessed and has a very wide dynamic range. The SMP line contains a pulse that can be used to sample the output of the E97S' opamp circuit output; the resulting signal can be used in analog systems directly or fed into a high performance ADC for further processing.

Gain Switch

This 2-position switch controls the gain of the opamp circuit. The 'Hi' position has 16x higher gain than the 'Lo' position. Refer to the schematic diagram for further details.

Analog Port

This connector provides an analog output signal which reflects the capacitance level. The analog signal is 'synthetic', that is, it is output by the QT9701B2 after it has been processed; the output type is determined by Setup U. Please refer to the QT9701B2 datasheet for further details on signal processing options. The signal on this connector differs from that available on the 'Sampled Analog Connector' by having been routed through the QT9701B2 first, at 8 bits of resolution. It can be filtered, re-zeroed, inverted, or made 'absolute value' by selecting the appropriate Setups options.

SPI Port

This output-only port allows transfers of data, such as signal levels and board status, to off-board peripherals which can take clocked data. Possible targets include shift registers and SPI peripherals like DACs. The signals available are the same as those available on the Analog port connector, but in clocked-digital form. Refer to the QT9701B2 datasheet for data format and clocking details.

Eeprom

The 93LC46A eeprom (socketed) contains the Setups and calibration data for the E97S. Data is nonvolatile and can be changed via the serial port or via the cloning process. If the eeprom is removed, the E97S board will not function correctly. Setups data in the eeprom can be reset to 'factory defaults' - See 'Factory Defaults' section.

BG Button

This button controls the recalibration of the Background level of the sensor. It is the primary control for setting the reference point and recalibrating the device. Pushing this button will normally act to recenter the signal and its reference level at the desired reference offset according to Setup 2, Reference Offset, in the table.

The control line for this button also appears on the Main Connector (see schematic and Main Connector notes above).

A great deal is written about the BG and OBJ functions in Section 3 of the QT9701B2 datasheet that is not repeated here.

Board Details

OBJ Button

This button controls the 'Object Learn' point of the sensor. It sets the trip point at which an object will be detected when the device is in the BG/OBJ or OBJ modes (see QT9701B2 datasheet for details). If this button is not pushed, the detection point is set to a level determined by Setups 0, Threshold.

The control line for this button also appears on the Main Connector (see schematic and Main Connector notes above).

Clone In Port

This is a connection port for a 'cloning adaptor' used to clone the feature setups from one E97S board to another, or from an external eeprom, or from an E2SR board. The QT9701B2 can read Setups information and program the data into the onboard eeprom via this port. For further details please refer to the QT9701B2 datasheet.

Clone Out Port

This connection port can be used to replicate Setups data in the E97S to other E97S boards or to a QTM1001AS module. The cloning adapter's cable plugs into this port.

Cs (C11) Capacitor

The primary sample capacitor, Cs, resides at C11 on the component side of the board. Additional land areas wired in parallel have been included both topside (C11C) and underneath (C11A, C11B) for additional types and sizes of capacitors should they be required for an application.

RT/CT Transfer Timing Parts

RT and CT (located below the eeprom) are sockets that can be used to narrow the QT sampling time for systems where water films are a problem. RT and CT allow enhanced water suppression by restricting the amount of time stored charge in the water film has to return to the sampling capacitor, C11. The 'normal' transfer time mirrors the charge time, and can extend down to 200ns (See Setups Table in QTWinView or the QT9701B2 datasheet). These 'normal' times are accessed by removing RT and placing a jumper in the socket pins for CT (factory default). By inserting a 470 to 4.7K resistor at RT and inserting a 20pF to 100pF capacitor for CT, a variety of transfer times can be obtained. These transfer times must be adjusted with the aid of an oscilloscope on TP1 (located near pin 1 of the eeprom). Transfer times well below 50ns are possible with this circuit.

STAT LED

This LED acts as a multipurpose indicator that shows output state, error conditions, and input feedback. STAT will output as follows depending on sensor state:

Running and not detecting: LED flickers at a 10% duty cycle.

Running and detecting: LED flickers at a 90% duty cycle (brighter flicker).

When either BG or OBJ are pushed: LED is forced off for the duration of the push.

If BG or OBJ are pushed for >2secs: (Change of cal mode requested) After button release, the LED will go 'solid on' (no flicker) for ¼ second before it enters the new calibration mode.

While calibrating: LED will be off; this usually takes under a second.

If a Sense line short-circuit is detected while running: LED will go 'solid on' for the duration of the short.

On a calibration error: LED will output a repeating error code, provided that Output Error Code function [E.a] is set 'on':

Single repeating pulse: CHG shorted to ground

Double repeating pulse: Excess capacitive load

Triple repeating pulse: Unstable signal, cannot calibrate

The device will repeatedly try to calibrate between each set of 'Morse code' signals. If [E.a] is off, the recalibration attempts will be much quicker, since the STAT codes are not output to the LED.

OUT LED

This LED reflects the state of the OUT line. If 'On', the OUT line is high. Note that the OUT line can be inverted in polarity using Setup 'J'. If set to 'Active Low', the LED will be off if a detection is sensed. The OUT signal can be stretched by configuring Setup 'L'.

Fresh Defaults

The E97S' factory defaults are shown in the accompanying Setups Table. These defaults are for a forgiving operation mode that requires only the press of the BG button for recalibration, and for a simple, low Baud rate connection to a PC.

Factory defaults can be restored to those shown by the following procedure:

1. Unpower the board
2. Hold down both the BG and OBJ buttons
3. While holding the buttons, reapply power and continue to hold the buttons for 3 more seconds.
4. Release the two buttons.

The board will now be in the factory default state, and will communicate at 9600 Baud with a host PC.

General Hints

Use QTWinView to observe signals and set up the sensor -

- ▶ Click on items in the 'grid' to quickly alter the Setups on the board.
- ▶ Be sure to load in the Grid for the 'QT9701B2' device before double-clicking on matrix cells.
- ▶ Change Setups by simply double-clicking on cells. Use the 'Save Grid' feature to save your own settings to a setup file on disk, and to even create a new button on the top button bar.
- ▶ Observe the relationship between the signal, the reference level, and the threshold points. This is the key to understanding the behavior of the sensor during detection, drift compensation, and calibration.
- ▶ Don't be afraid to change Setups to wild combinations. You can't break it.
- ▶ If you make a mistake that causes the board to stop communicating with the PC, use the 'Fresh Defaults' method above to restore the board to 'factory defaults'.

Use rubber feet under the board, or mount it on something -

- ▶ Mechanical stability is important even on the board itself. A loose board can cause small signal variations that you might find hard to explain.
- ▶ Keep the electrode stable for the same reasons.

Refer to the QT9701B2 datasheet -

- ▶ The datasheet has loads of information that will help you understand the product, including circuit operation details. Only an extract of that information appears here.

Trouble-Shooting

Will not communicate with the PC

- ▶ Bad serial connections
 - ⇒ Check/replace serial cable
- ▶ Bad or conflicting Comm port on PC
 - ⇒ Shut down other tasks that may also be using the same comm port, IRQ or I/O Address on the PC.
 - ⇒ Use a different PC.
- ▶ E97S Baud rate setting changed inadvertently
 - ⇒ Restore factory defaults into E97S (see 'Fresh Defaults' section)
- ▶ Dead battery or power supply out of usable range
 - ⇒ Restore power to within correct range

LEDs not working as expected

- ▶ Wrong Setups mode
 - ⇒ Check or restore Setups, and / or,
 - ⇒ Hold down BG for 3 seconds
- ▶ Eeprom wrong type or eeprom not inserted
- ▶ Shorted sense line
 - ⇒ Restore power to within correct range

Board will not calibrate

- ▶ Excess capacitive load
 - ⇒ Reduce burst length, or,
 - ⇒ Reduce Cx loading
- ▶ Shorted sense line
- ▶ Low power supply voltage
- ▶ Unstable capacitance load due to electrode or wiring

Noisy signal

- ▶ Noise on power supply
 - ⇒ Add supply filtering capacitors
 - ⇒ Use a local supply regulator
- ▶ Electrode too close to power wiring
- ▶ Noisy load connected OUT line
- ▶ Ground loop interference
- ▶ RFI from a transmitter or adjacent digital product
 - ⇒ Add some series-R to the electrode lead
 - ⇒ Shield the board in a metal box
- ▶ Insufficient signal filtering
 - ⇒ Increase amount of median and/or boxcar filtering

QT9701B2 Setups *Bold Boxes Denote Factory Default settings*

SELECT	DESCRIPTION	SETTING									
		0	1	2	3	4	5	6	7	8	9
0	Detect Threshold, counts	62	40	32	25	19	14	11	8	6	4
1	Hysteresis, % of Threshold	50	25	12.5	0						
2	Reference Offset (hex / decimal)	0x10 / 16	0x20 / 32	0x40 / 64	0x60 / 96	0x70 / 112	0x80 / 128	0xA0 / 160	0xC0 / 192	0xE0 / 224	0xF0 / 240
3	unused										
4	Pulse Width - ns	200	400	600	800	1,000	1,200	1,400			
5	Burst Length, pulses	4	8	16	24	32	40	48	56	64	‡
6	Burst Spacing	200µs	500µs	1ms	2ms	5ms	10ms	20ms	50ms	100ms	‡
7	Randomize Bursts, %	off	12.5%	25%	50%	‡					
8	Drift Rate, seconds/bit	off	100	50	20	10	5	2	1	0.5	0.2
9	Median Filter, length	off	5	9							
A	Boxcar Average, length	off	2	4	8	16	32	64	‡		
B	Detect Integrator, counts	off	1	2	5	10	20	50	100	200	‡
C	Max On-Duration, seconds	infinite	100	50	20	10	5	2	1	0.5	0.2
D	Detection Mode										
D.a	Output on positive signals	X	X	X	X	X	X				
D.b	Output on negative signals					X	X	X	X	X	X
D.c	Max On-Duration engages on +/- crossing	+	+	+/-	+/-	+/-	+/-	+/-	+/-	-	-
D.d	Drift compensation during detect		X		X		X		X		X
E	Calibration control										
E.a	output error code if cal error	off	on	off	on						
E.b	recal if ref drifts into boundary	on	on	off	off						
F	Drift Store / Data Locking / Motion										
F.a	Drift store interval, minutes between saves	off*	off	1	2	5	10	15	30	60	motion
F.b	Data locking	off*	on	on	on	on	on	on	on	on	off
G	Serial Modes / UART Rate	Off	9.6P	19.2P	57.6P	115P	9.6V	9.6VS	19.2V	57.6V	115V
H	Verbose Data	synth	synth-ref	ref	offset	canceltn	DI	from U	status	err code	
J	Polarities										
	OUT pin: Active =	High	Low	High	Low						
	XFR pin: Drive =	High	High	Low	Low						
L	Output Stretch, seconds	0	0.1	0.2	0.5	1	2	3	5	7	10
N	unused										
P	SPI Format	8 bits	16 bits								
U	Mode / SPI Data Output	Mode_1	Raw	Synth	+Synth	-Synth	Synth	Ref	DI	Status	

E97S Board Schematic

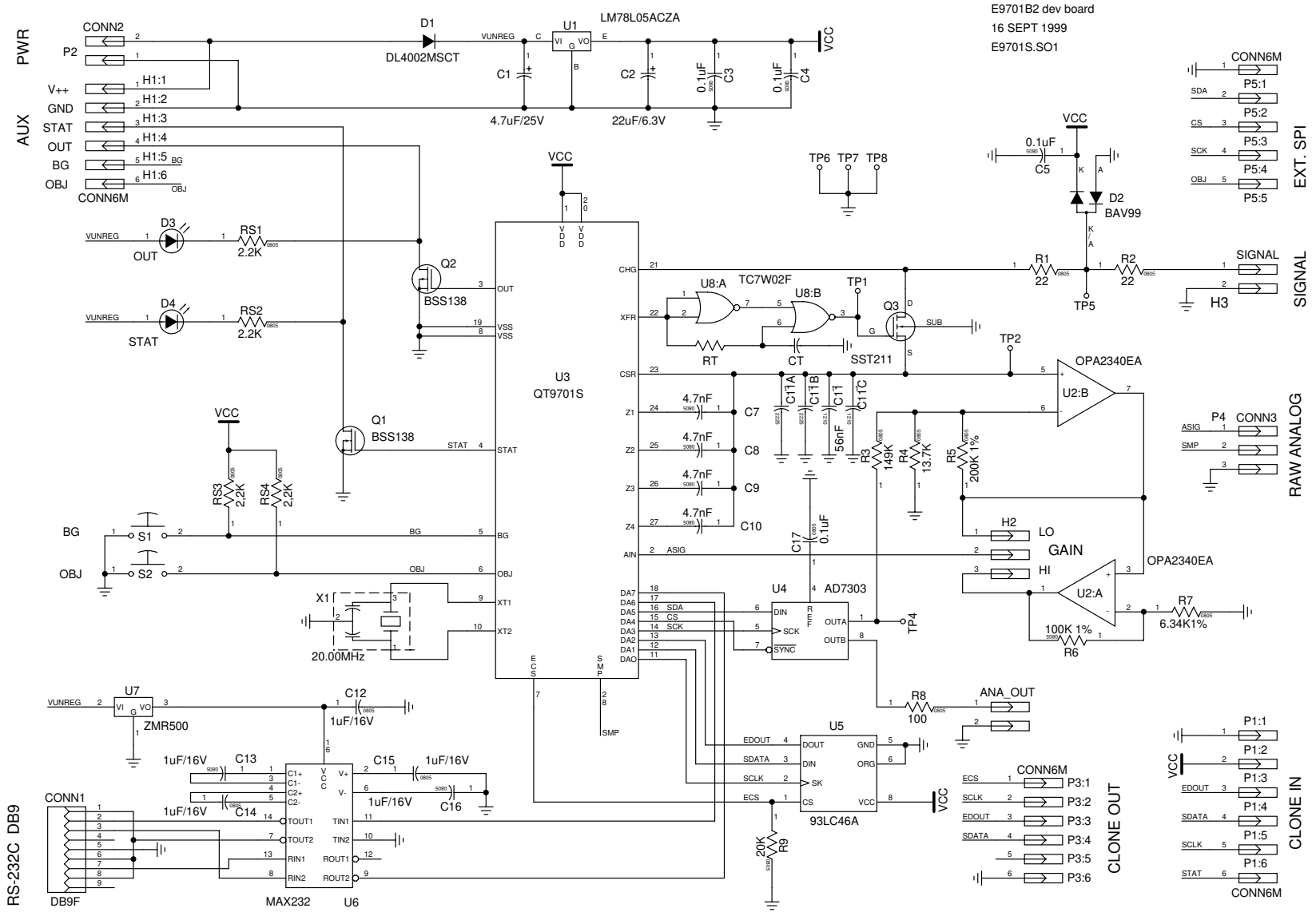

E97S PCB LAYERS

**Silk
Layer**

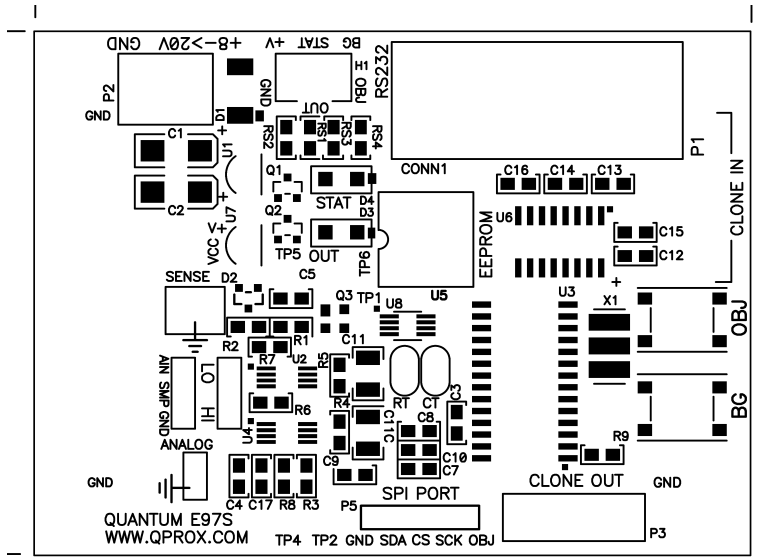

**Component
Layer**

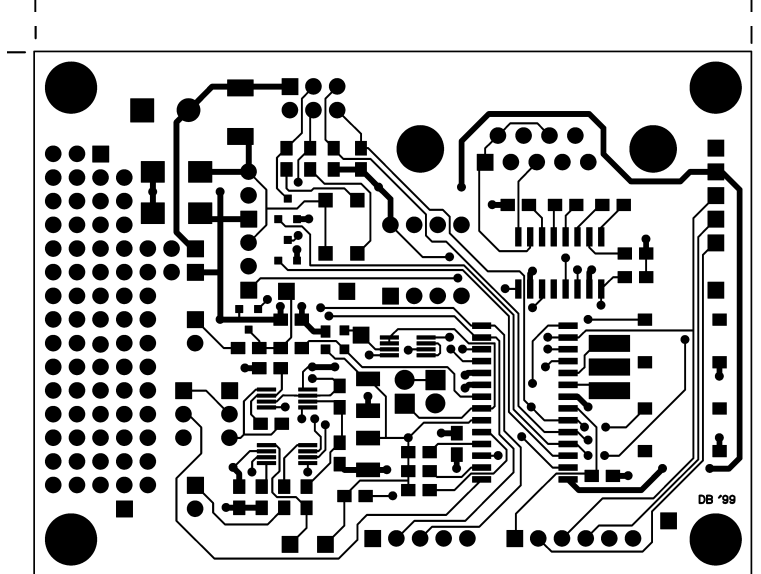

**Solder
Layer**

