



Chipsmall Limited consists of a professional team with an average of over 10 year of expertise in the distribution of electronic components. Based in Hongkong, we have already established firm and mutual-benefit business relationships with customers from,Europe,America and south Asia,supplying obsolete and hard-to-find components to meet their specific needs.

With the principle of “Quality Parts,Customers Priority,Honest Operation,and Considerate Service”,our business mainly focus on the distribution of electronic components. Line cards we deal with include Microchip,ALPS,ROHM,Xilinx,Pulse,ON,Everlight and Freescale. Main products comprise IC,Modules,Potentiometer,IC Socket,Relay,Connector.Our parts cover such applications as commercial,industrial, and automotives areas.

We are looking forward to setting up business relationship with you and hope to provide you with the best service and solution. Let us make a better world for our industry!



Contact us

Tel: +86-755-8981 8866 Fax: +86-755-8427 6832

Email & Skype: info@chipsmall.com Web: www.chipsmall.com

Address: A1208, Overseas Decoration Building, #122 Zhenhua RD., Futian, Shenzhen, China



I²C Digital Ambient Light Sensor – Surface Mount EAALSDIC2020A0



Features

- Close to the human eye's response
- 15 bit effective resolution
- 50Hz/60Hz rejection
- Low sensitivity variation across various light sources
- Operating temperature performance, -40oC to 85oC
- Wide supply voltage range, 2.7V to 5.5V
- Low power consumption, less than 2mW while operating
- Shut-down mode, current consumption less than 0.1uA
- I2C serial port communication: (1) Standard 100kHz, (2).Fast 400kHz
- High dynamic sensing range and from 0 to 88,400 Lux
- Size: 2.0mm(L)*2.0mm(W)*0.6mm(H)
- RoHS compliant and Pb Free
- Compliance with EU REACH.

Description

The EAALSDIC2020A0 is a digital-output light sensor with a two-wire, I²C serial interface that is compatible with SMBus when working at 100kHz serial clock frequency. It combines a photodiode and an analog-to-digital converter (ADC) on a single CMOS integrated circuit to provide light measurements over an effective 15-bit dynamic range. Two operation modes are provided with one for constantly refreshing ADC and the other for one time integration. When working in “one time integration” mode, no external resistor is required. The integrating conversion technique used by EAALSDIC2020A0 effectively eliminates the effect of flicker from AC-powered lamps, increasing the stability of the measurement. EAALSDIC2020A0 wavelength is close to human-eye, and low response to non-visible light, such as infrared and ultra-violet light.

Applications

- Detection of ambient light for controlling the backlighting of TFT LCD display
- Automatic residential and commercial lighting management
- Automatic contrast enhancement for electronic signboard
- Ambient light monitoring device for daylight and artificial light

Package Dimensions

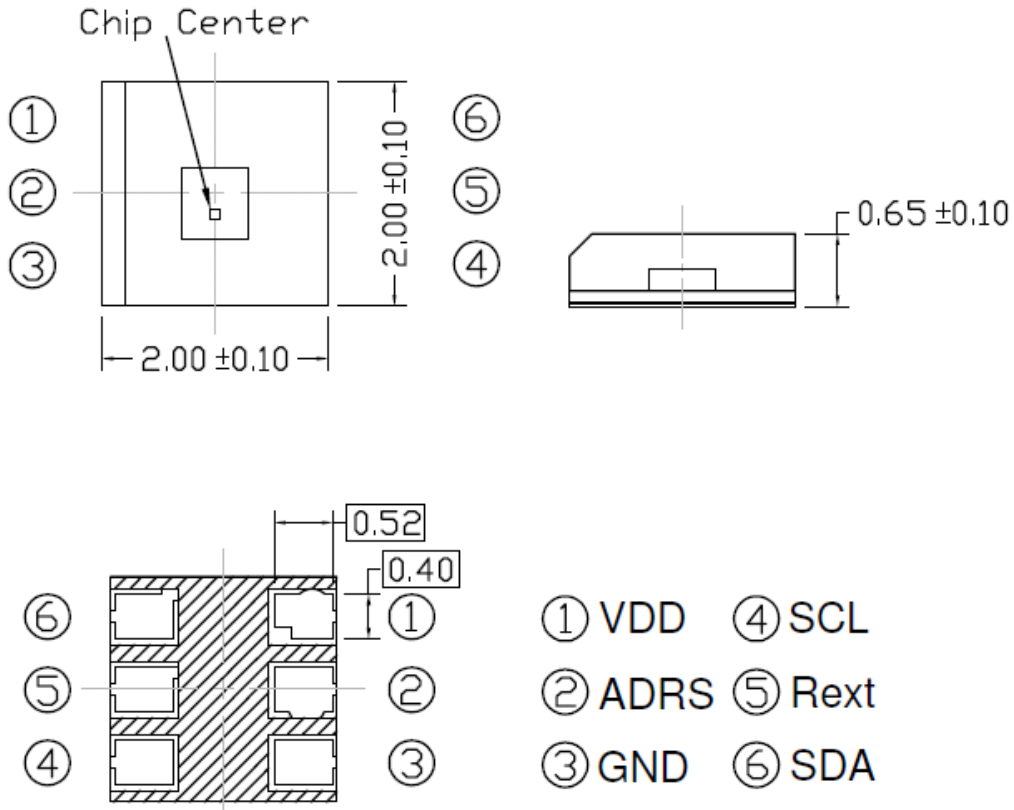

Note: Tolerances unless mentioned ±0.1mm. Unit = mm

Absolute Maximum Ratings (Ta=25°C)

Parameter	Symbol	Rating	Unit
Storage Temperature	T _{STG}	-40 ~ 100	°C
Operating Temperature	T _{OPR}	-40 ~ 85	°C
Supply Voltage	V _{DD}	-0.3 ~ 6	V
Digital Output Voltage	V _O	-0.3 ~ 6	V
Digital Output Current	I _O	-10 ~ 10	mA
ESD Tolerance (Human Body Model)	ESD _{HBM}	3500	V
ESD Tolerance (Machine Model)	ESD _{MM}	150	V

Block Diagram & Pad Descriptions

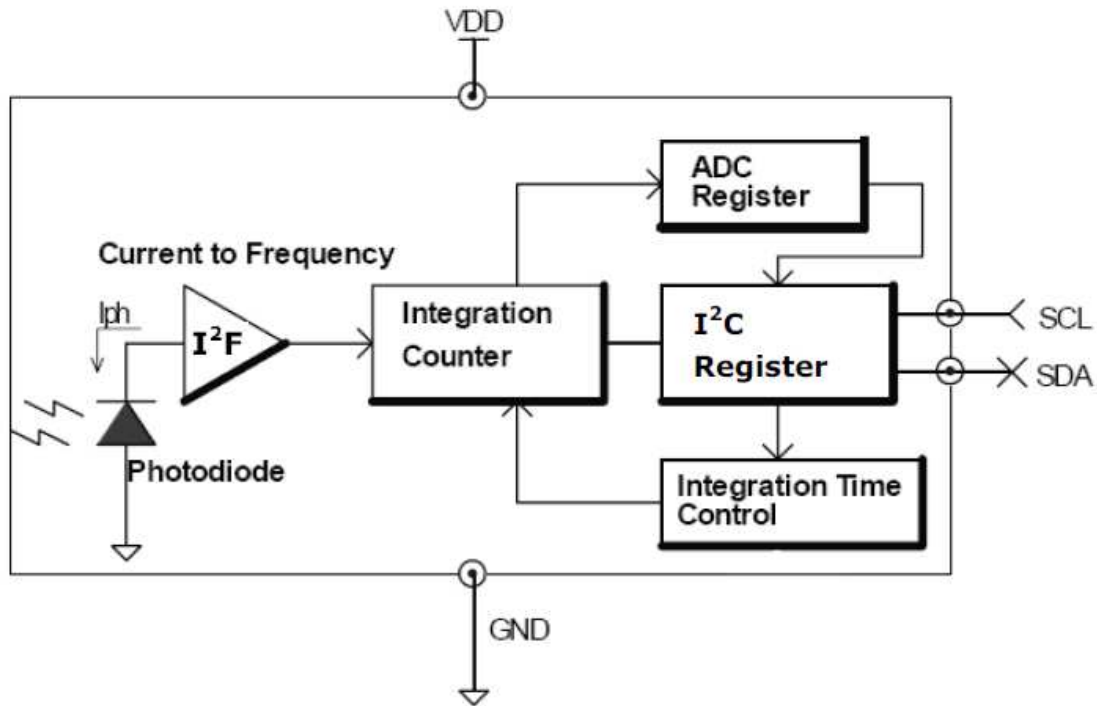

Figure 1. EAALSDIC2020A0 Functional Block Diagram

Pad	I/O	Function
VDD	Power	Supply Voltage
GND	Power	Power and signal return
REXT	Input	Connecting a resistor to GND for adjusting integration time
SDA	I/O	I ² C data input/output terminal
SCL	Input	I ² C serial clock input terminal
ADRS	I/P	I ² C address option pad

Electro-Optical Characteristics (Ta=25°C)

Parameter	Symbol	Min.	Typ.	Max.	Unit	Condition
Active Mode Supply Current	I _{DD}	-----	0.4	0.5	mA	V _{DD} =3.3V
Power-Down Mode Supply Current	I _{DDQ}	-----	-----	0.1	μA	V _{DD} =3.3V
Detection Full Counts		-----	-----	32767	Counts	
Detection Limit		-----	44200	-----	Lux	T _{INT} =100mS
Peak Sensitivity Wavelength	λ _P	-----	550	-----	nm	
Response in Dark Environment	R _{DAK}	-----	----	1	Count	V _{DD} =3.3V E _V =0Lux T _{INT} =100ms
Response in Fluorescent Light	R _{FRST100}	44	73	102	Counts	V _{DD} =3.3V E _V =100Lux T _{INT} =100mS
Response in Fluorescent Light	R _{FRST1000}	440	730	1020	Counts	V _{DD} =3.3V E _V =1000Lux T _{INT} =100mS

Note:

1. White Fluorescent light (Color Temperature = 6500K) is used as light source. However, White LED is substituted in mass production.

DC Characteristics of I²C Signals in Standard and Fast Mode

Parameter	Symbol	Standard Mode		Fast Mode		Unit
		Min.	Max.	Min.	Max	
Power Supply Voltage (Recommend)	V _{DD}	2.7	5.5	2.7	5.5	V
Low Level Input Voltage	V _{IL}	-0.5	1	-0.5	1	V
High Level Input Voltage	V _{IH}	-----	V _{DD} *0.6	-----	V _{DD} *0.6	V
Hysteresis of Schmitt trigger inputs (V _{DD} > 2V)	V _{HYS}	0.05*V _{DD}	-----	0.05*V _{DD}	-----	V
Low level output voltage (open drain) at 3mA sink current (V _{DD} > 2V)	V _{OL1}	0	0.4	0	0.4	V
Output fall time from V _{IHMIN} to V _{ILMAX} with a bus capacitance from 10pF to 400pF	T _{OF}	-----	250 ^[2]	20+0.1Cb ^[1]	250 ^[2]	nS
Input current of each IO pins with an input voltage between 0.1V _{DD} and 0.9V _{DD}	I _{INPUT}	-10	10	-10	10	μA
Capacitance for each IO pin	C _I	-----	10	-----	10	pF

Notes:

1. Cb = capacitance of one bus line in pF
2. The maximum T_{of} for the I²C data and clock bus lines quoted in the AC table is longer than the specified maximum T_{of} for the output stages (250nS). This allows series protection resistors (RS) to be connected between I²C data / clock pins and the I²C data / clock bus lines without exceeding the maximum specified tof.

AC Characteristics of I²C Signals in Standard and Fast Mode

Parameter	Symbol	Standard Mode		Fast Mode		Unit
		Min.	Max.	Min.	Max	
I ² C clock frequency	f _{SCL}	0	100	0	400	KHz
Hold time (repeated) START condition. After this period, the first clock pulse is generated.	t _{HD;STA}	4.0	----	0.6	----	μs
Low period of I ² C clock	t _{LOW}	4.7	----	1.3	----	μs
High period of I ² C clock	t _{HIGH}	4.0	----	0.6	----	μs
Set-up time for a repeated START condition	t _{SU;STA}	4.7	----	0.6	----	μs
Data hold time for I ² C-bus devices	t _{HD;DAT}	0	3.45	0	0.9	μs
Data set-up time	t _{SU;DAT}	250	----	100	----	ns
Rise time of both I ² C data and clock signal's	t _r	----	1000	5	300	ns
Fall time of both I ² C data and clock signal's	t _f	----	300	0.1	300	ns
Set-up time for STOP condition	t _{SU;STO}	4.0	----	0.6	----	μs
Bus free time between STOP and START condition	t _{BUF}	4.7	----	1.3	----	μs
Capacitive load for each bus line	C _b	----	400	----	400	pF

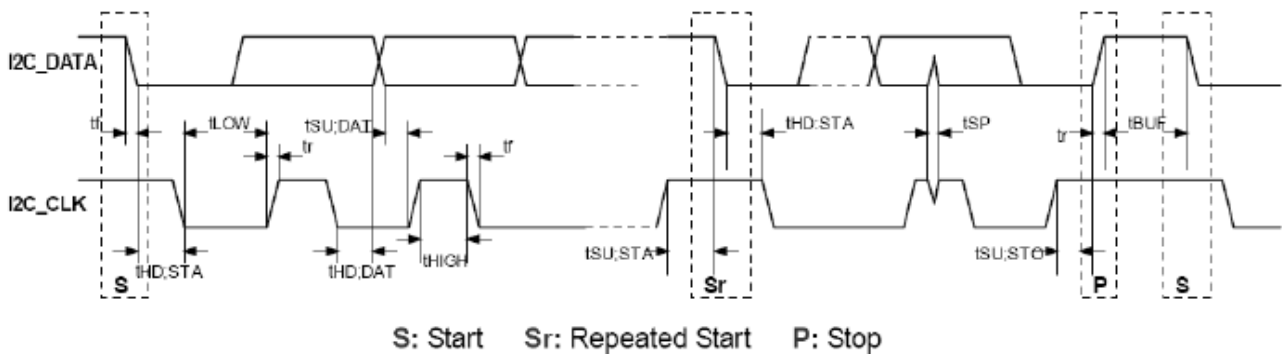

Figure 2. I²C Timing Diagram

Typical Electro-Optical Characteristics Curves

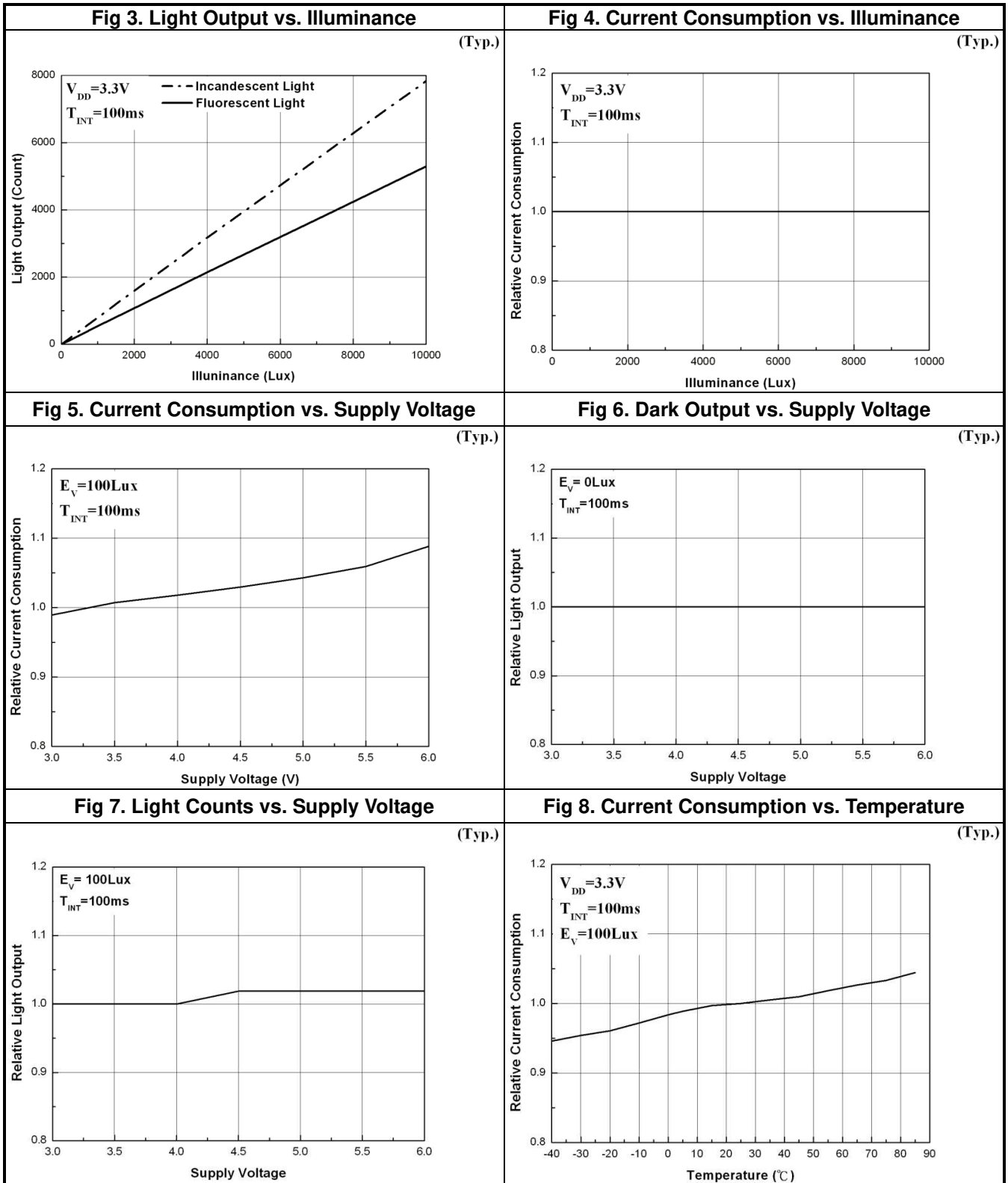

Fig 9. Dark Counts vs. Temperature

(Typ.)

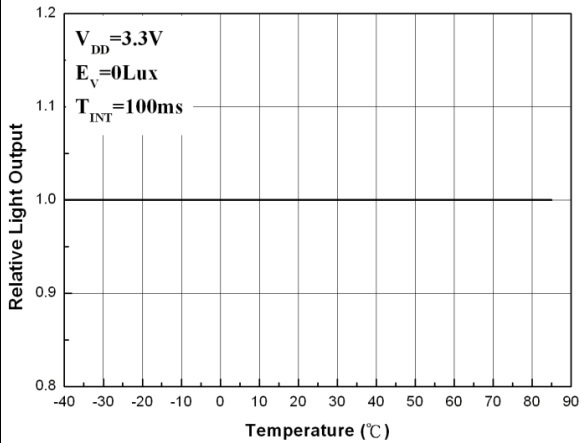

Fig 10. Light Counts vs. Temperature

(Typ.)

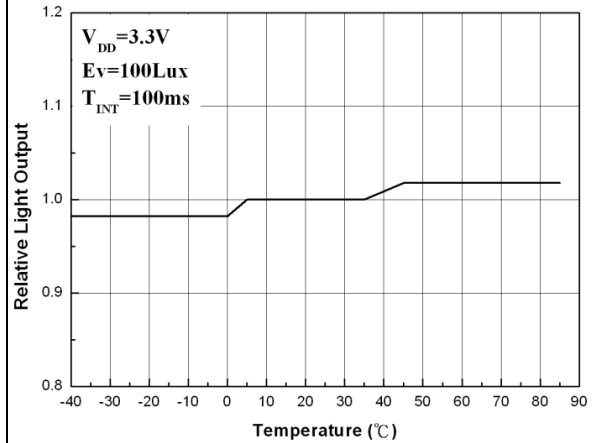

Fig 11. Spectrum

(Typ.)

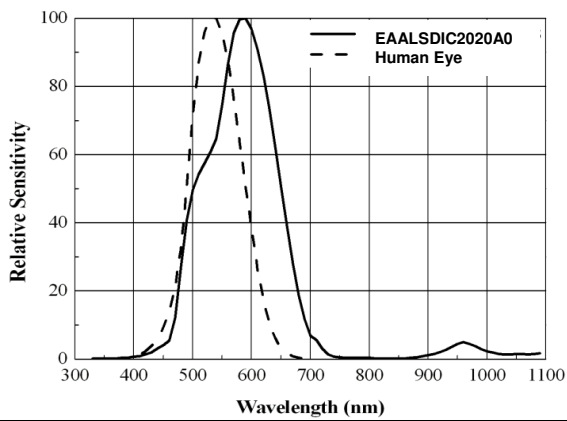
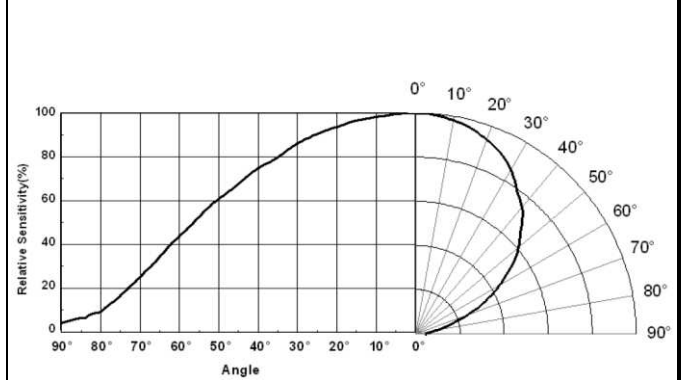

Fig 12. Relative Sensitivity vs. Angle



Communication Protocol

EAALSDIC2020A0 contains an 8-bit command register that can be written and read via the I²C bus. The command register controls the overall operation of the device. There is a two-byte word read-only register that contains the latest converted value of A/D converter. The I²C slave address is hardwired internally as 0101001 (0x29, MSB to LSB, A6 to A0). All the Send Byte protocol, the Receive Byte protocol and Receive Word protocol are implemented in EAALSDIC2020A0.

The Send Byte protocol allows single byte of data to be written to the device (see Figure 13-a). The written byte is called the COMMAND byte. The Receive Byte protocol allows one-byte data to be read from the device (see Figure 13-b). Two-byte data can be read by following the Receive Word Protocol shown in Figure 13-c. In Figure 13, the clear area represents data sent by the host (master) and the shaded area represents data returned by the ambient light sensor (slave device).

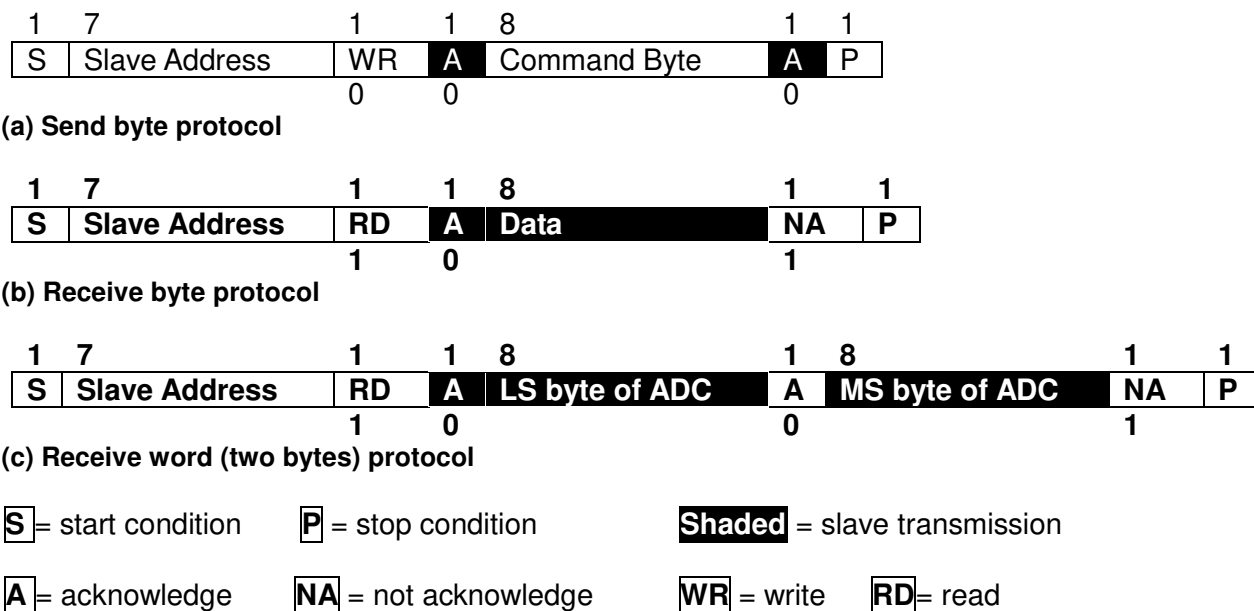

Figure 13. Communication Protocol

Communication Format

EAALSDIC2020A0 is capable of working as an I²C slave. Address of this device on I²C bus is always 0x29 (hexadecimal number 29). Registers of the slave device can be programmed by sending commands over I²C bus.

Figure 14 shows an I²C write operation. To write to an internal register of the slave device a command must be sent by an I²C master. As illustrated in Figure 14, the I²C write command begins with a start condition. After the start condition, seven bits of address are sent with MSB going first. RD / WR_n (=Low) command bit follows the address bits. Upon receiving a valid address the slave device responds by driving SDA low for an ACK. After receiving an ACK, I²C master sends eight bits of data with MSB first. Upon receiving eight bits of data the slave device generates an ACK. I²C master terminates this write command with a stop condition.

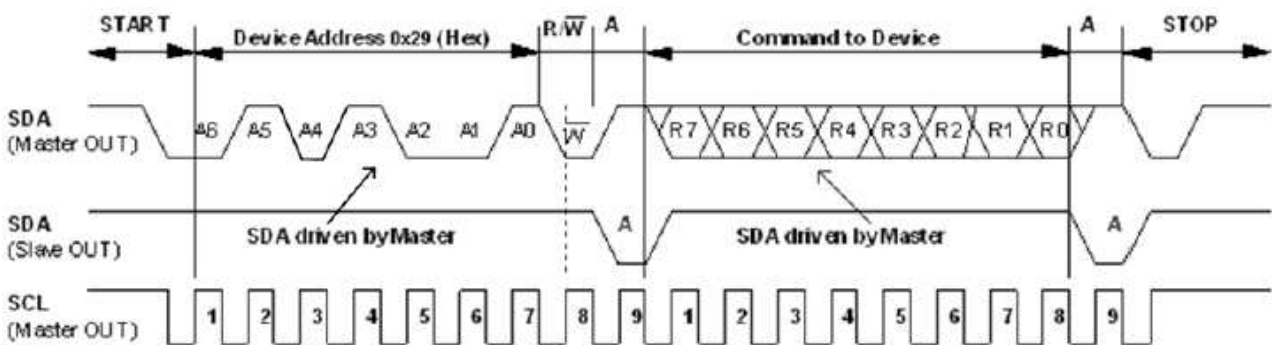

Figure 14. I²C Timing Diagram for Send Byte Format

Figure 15 shows an I²C read command sent by the master to the slave device. I²C read command begins with a start condition. After the start condition seven bits of address are sent by the master with MSB going first. After the address bits, RD / WR_n command bit is sent. For a read command the RD / WR_n bits is high. Upon receiving the address bits and RD / WR_n command bits the slave device responds with an ACK. After sending an ACK, the slave device sends eight bits of data with MSB going first. After receiving the one byte data, the I²C master terminates this transaction by issuing a NACK command to indicate that the master only wanted to read one byte from the device. The master generates a stop condition to end this transaction.

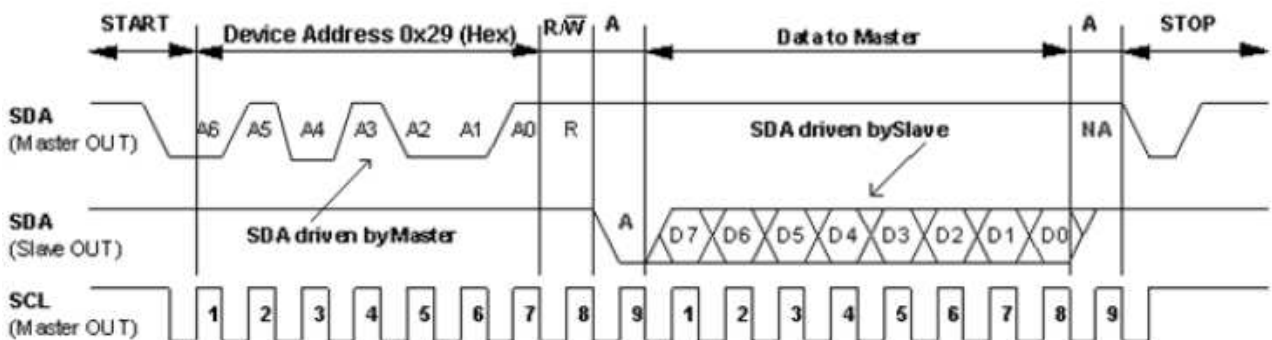

Figure 15. I²C Timing Diagram for Receive Byte Format

Ambient light intensity count value can be obtained by reading registers of this device. Ambient light intensity count is a 15-bit wide number plus a valid bit and hence word (two bytes) read operation is needed, as shown in Figure 16. After receiving the two byte data, the I²C master terminates this transaction by issuing a NACK command to indicate that the master only wanted to read two bytes from the device. The master generates a stop condition to end this transaction.

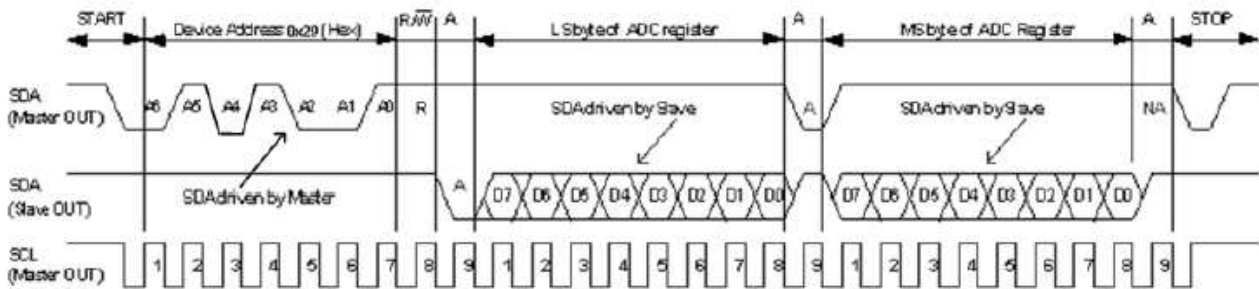

Figure 16. I²C Timing Diagram for Receive Word Format

Theory of Operation

The photocurrent, generated by the built-in photodiode while being illuminated, is proportionally converted to frequency; the digital frequency signal is then integrated by a 15-bit counter for a predetermined period of time (T_{int}). This period of time is called integration time which can be adjusted by changing the nominal value of the resistor between the R_{INT} and GND terminals. The converted data are read out through a two-wire, I²C Interface bus. Since the photodiode has been specially processed to suppress the spectral response in infrared region, the readout is very close to the photopic transfer function, $v(\lambda)$, which is the mathematic expression of human-eye's response to ambient light.

Address Option for I²C

The I²C address is determined before placing an order; users can assign any one of the three addresses (0x39, 0x29, 0x44) for their specific application. Without any prior request for a specific I²C address, the default address is 0x39.

Address Pin Configuration	I ² C Address
Floating	0x39 (default)
Tied to GND	0x29
Tied to VCC	0x44

Table 1 Connecting options of I²C address

ADC Register

The ADC register contains 16 bits with a 15-bit wide data from D0 to D14 and a valid bit D15. The register is divided into two groups; D[15..8] is the most significant (MS) byte and D[7..0] is the least significant (LS) byte. See Table 2 for details.

Valid Bit	Data Bits			
D15	D14	D13 ~ D8	D7~D1	D0
	MSB			LSB
Most Significant (MS) byte			Least Significant (LS) byte	

Table 2 ADC. Register Structure

Device Command

There are three command codes are provided for I²C master to control the ambient light sensor. The specific function corresponding to each command code is elaborate in Table 3.

Command Code	Function
1xxx_xxxx (binary code)	Shut-down mode, this is the default state after applying V _{DD} power to the device. During shut-down mode, users can do the communication test. Except the MSB must be logic 1, the value written to the command register will not change any function and can be read back via the I ² C bus by issuing <i>Receive Byte Protocol</i> .
0x0C	Activate the ambient light sensor and put the device in [continuous operation mode], The ADC register will be refreshed every T _{int} integration time which is set by an external resistor R _{ext} . See Table 4 for details.
0x04	Activate the ambient light sensor and put the device in [one time integration mode]. The integration time is controlled by I ² C commands, start and stop integration.
0x08	Start integration: This command will reset the ADC register to 0x0000 and begin a new integration in [one time integration mode]. This is an invalid command in [continuous operation mode].
0x30	Stop integration: This command will stop the integration in [one time integration mode] and set the valid bit (D[15]) high. This is an invalid command in [continuous operation mode].

Table 3 Command Code List

Programming Sequence

Case 1: Using internal integration timing

- (1). After being powered on, the device will initially be in the shut-down mode (default setting).
- (2). To operate the device, issue an Send Byte protocol (see Figure 13-a) with the device address 0x39 followed by a command byte of 0x0C to activate the ambient light sensor and put the device into "continuous operation mode".
- (3). To read the ADC conversion result, issue an Receive Word protocol (see Figure 13-c) with the device address 0x39 followed by two-byte reading procedures.
- (4). If a conversion has not been completed since being activated, the valid bit (D[15]) will be 0 to indicate that the data is not valid. If there is a valid conversion result available, the valid bit (D[15]) will be set logic high, and the remaining 15 bits will represent valid data from the ADC register.
- (5). Data may be read repeatedly from the ADC register, and although it will remain valid, the ADC register will not be updated until a new conversion completes.

Case 2: Using external integration timing

- (1). After being powered on, the device will initially be in the shut-down mode (default setting).
- (2). To operate the device, issue an Send Byte protocol (see Figure 13-a) with the device address 0x39 followed by a command byte of 0x04 to activate the ambient light sensor and put the device into "one time integration mode".
- (3). I²C master sends a "start integration command" to the slave device by issuing Send Byte protocol with the device address 0x39 followed by a command byte of binary code (1xxx_xxxx).
- (4). After a period of user defined integration time, I²C master sends a "stop integration command" to the slave device by issuing Send Byte protocol with the device address 0x39 followed by a command byte of 0x30.
- (5). To read the ADC conversion result, issue an Receive Word protocol (see Figure 13-c) with the device address 0x39 followed by two-byte reading procedures.
- (6). If the stop integration command is not received by the device, the valid bit (D [15]) will be "0" to indicate that the data is not valid. If there is a valid conversion result available, the valid bit (D [15]) will be set logic high, and the remaining 15 bits will represent valid data from the ADC register.
- (7). Data may be read repeatedly from the ADC register, and although it will remain valid, the ADC register will not be updated until a new complete integration cycle has been carried out.

In both cases, the power consumption of the device can be reduced by issue an Send Byte protocol with the device address 0x39 followed by a data byte of 1xxx_xxxx.(Binary code)

Noise Rejection and Integration Time

In general, integrating type ADC's have an excellent noise rejection characteristics for periodic noise sources whose frequency is an integer multiple of the integration time. For instance, a 60Hz AC unwanted signal's sum from 0ms to $n \cdot 16.66\text{ms}$ ($n = 1, 2, \dots, n_i$) is zero. Similarly, setting the EAALSDIC2020A0 integration time to an integer multiple of periodic noise signal greatly improves the light sensor output signal in the presence of noise. The integration time, T_{int} , of the EAALSDIC2020A0 is set by an external resistor R_{ext} . The maximum detection range is inversely proportional to the integration time; that means the longer integration time the lower detection range.

Integration time (mS)	Detection range (Lux)	Resolution (Lux / Count)
50	88,400	2.7
100	44,200	1.35
200	22,200	0.68
300	14,500	0.45
400	11,100	0.34

Table 4. Detection Range Guide

In order to achieve both 60Hz and 50Hz AC rejection, the integration time needs to be adjusted to coincide with an integer multiple of the AC noise cycle times. To determine a suitable integration time, T_{int} , that will ignore the presence of both 60Hz and 50Hz noise, users can use the formula:

$$T_{int} = n(1/60\text{Hz}) = m(1/50\text{Hz}), \text{ where } n \text{ and } m \text{ are integers.}$$

$$n/m = 60\text{Hz}/50\text{Hz} = 6/5.$$

The first instance of integer values at which T_{int} rejects both 60Hz and 50Hz is when $m = 5$, and $n = 6$, thus,

$$T_{int} = 6(1/60\text{Hz}) = 5(1/50\text{Hz}) = 100\text{ms},$$

$$R_{ext} = T_{int} \cdot (100\text{k}\Omega/100\text{ms}) = 100\text{k}\Omega, \text{ (see Table 4)}$$

By populating $R_{ext} = 100\text{k}\Omega$, EAALSDIC2020A0 defaults to 100ms integration time in continuous operation mode, and will reject the presence of both 60Hz and 50Hz power line signals. When working in one-time integration mode, the master must control the integration time to be an integer multiple of 100ms.

Power Supply Decoupling and Layout

The power supply lines must be decoupled with capacitors, 4.7 μ F and 0.1 μ F, placed as close to the device package as possible. The bypass capacitor should have low effective series resistance (ESR) and effective series inductance (ESI), such as the common ceramic types, which provide a low impedance path to ground at high frequencies to handle transient currents caused by internal logic switching. EAALSDIC2020A0 is relatively insensitive to layout. Like other I²C devices, it is intended to provide excellent performance even in significantly noisy environments. There are only a few considerations that will ensure best performance. Route the supply and I²C traces as far as possible from all sources of noise. Use two power-supply decoupling capacitors, 4.7 μ F and 0.1 μ F, placed close to the device.

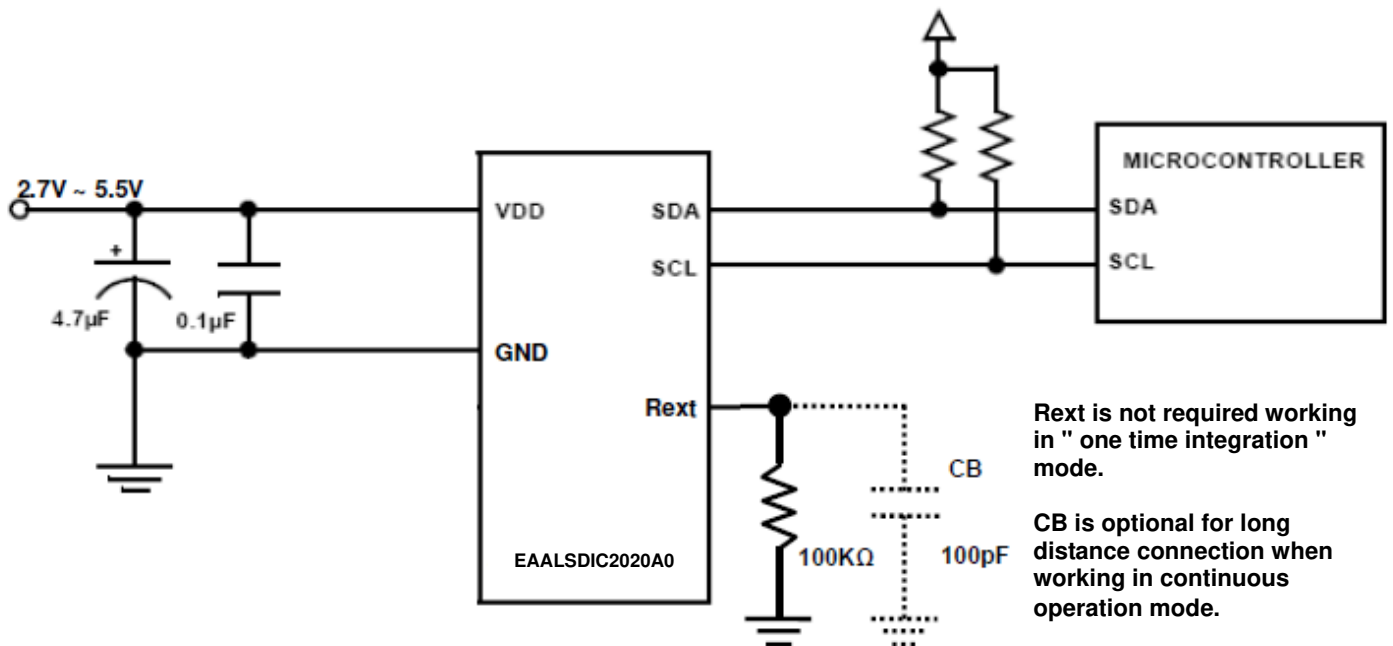
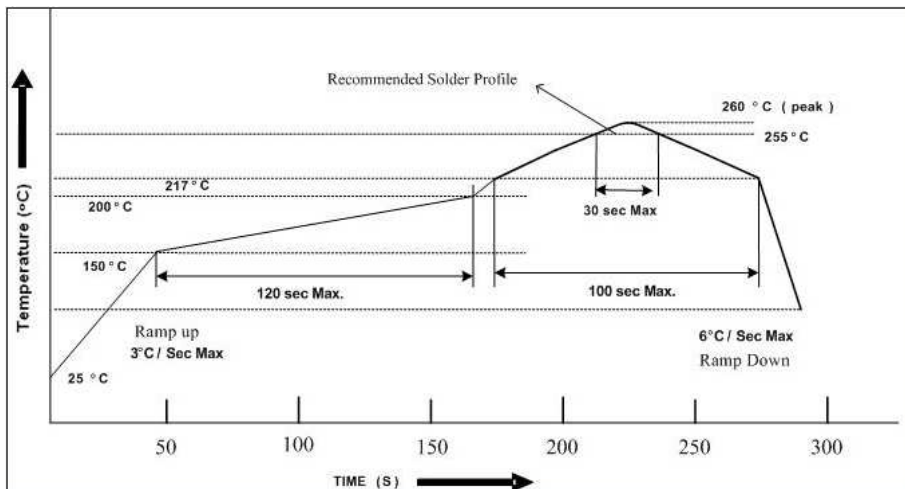

Figure 17. Application Circuit

Recommended method of storage

1. Do not open moisture proof bag before devices are ready to use.
2. Shelf life in sealed bag from the bag seal date:
 18 months at 10°C~30°C and < 90% RH.
3. After opening the package, the devices must be stored at 10°C~30°C and 60%RH, and used within 168 hours (floor life).
4. If the moisture absorbent material (desiccant material) has faded or unopened bag has exceeded the shelf life or devices (out of bag) have exceeded the floor life, baking treatment is required.
5. If baking is required, refer to IPC/JEDEC J-STD-033 for bake procedure or recommend the following conditions:
 312 hours at 40°C and < 5 % RH (reeled/tubed/loose units) or
 33 hours at 90°C and < 5 % RH (reeled/tubed/loose units) or
 9 hours at 125°C, not suitable for reel or tubes.

Recommended Solder Profile



Notice:

1. Reflow soldering should not be done more than two times.
2. When soldering, do not put stress on the devices during heating.
3. After soldering, do not warp the circuit board.
4. Reference: IPC/JEDEC J-STD-020D
5. Recommend soldering pad as drawing.

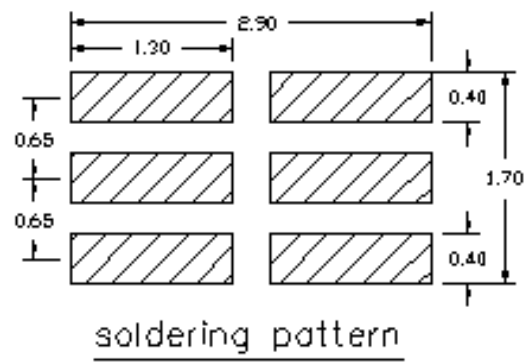

Soldering Iron

Each terminal is to go to the tip of soldering iron temperature less than 350°C for 3 seconds within once in less than the soldering iron capacity 25W. Leave two seconds and more intervals, and do soldering of each terminal. Be careful because the damage of the product is often started at the time of the hand solder.

Repairing

Repair should not be done after the device have been soldered. When repairing is unavoidable, a double-head soldering iron should be used (as below figure). It should be confirmed beforehand whether the characteristics of the device will or will not be damaged by repairing.

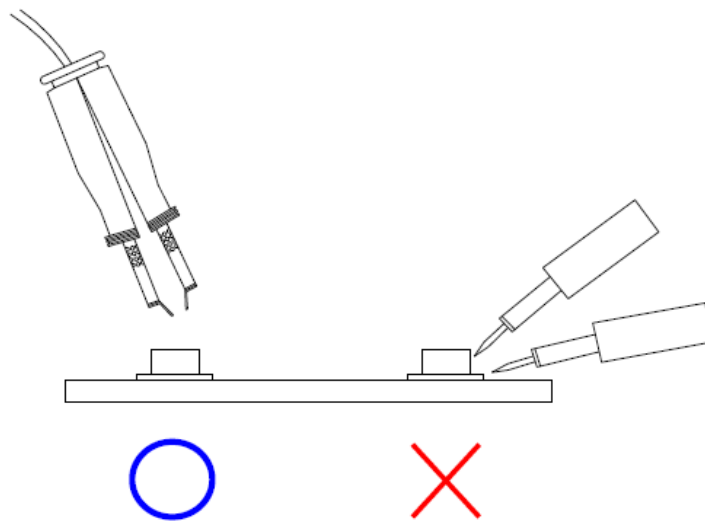

Package Quantity Specification

2000 PCS/ 1 Reel

Label Format



- CPN: Customer's Product Number
- P/N: Product Number
- QTY: Packing Quantity
- CAT: Luminous Intensity Rank
- HUE: Dom. Wavelength Rank
- REF: Forward Voltage Rank
- LOT No: Lot Number
- MADE IN TAIWAN: Production Place

Reel Dimensions

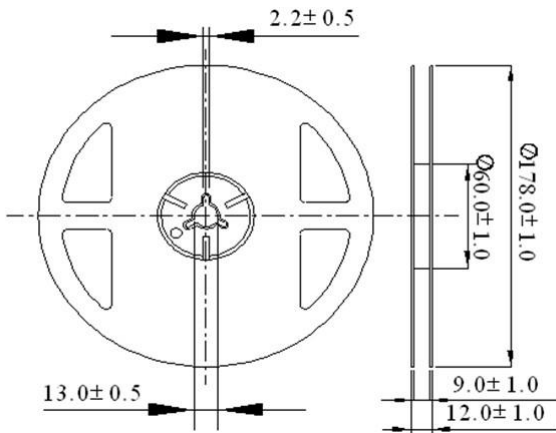

Tape Dimensions

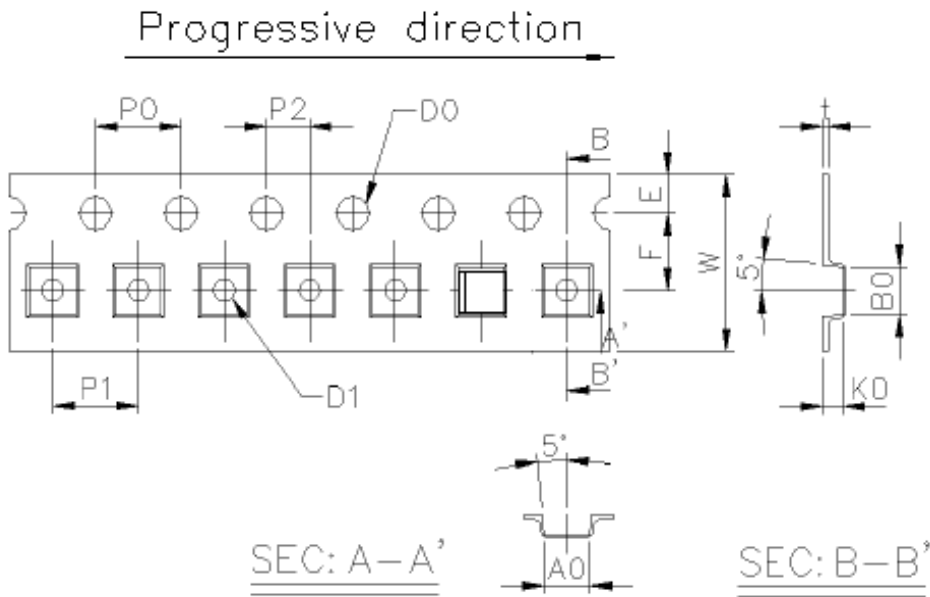

W	E	F	D0	D1	P0
8.00±0.2	1.75±0.1	3.50±0.05	1.50+0.1/-0	1.00±0.1	4.00±0.05
P1	P2	t	A0	B0	K0
4.00±0.1	2.00±0.05	0.23±0.05	2.15±0.05	2.15±0.05	0.95±0.05

Moisture Resistant Packing Process

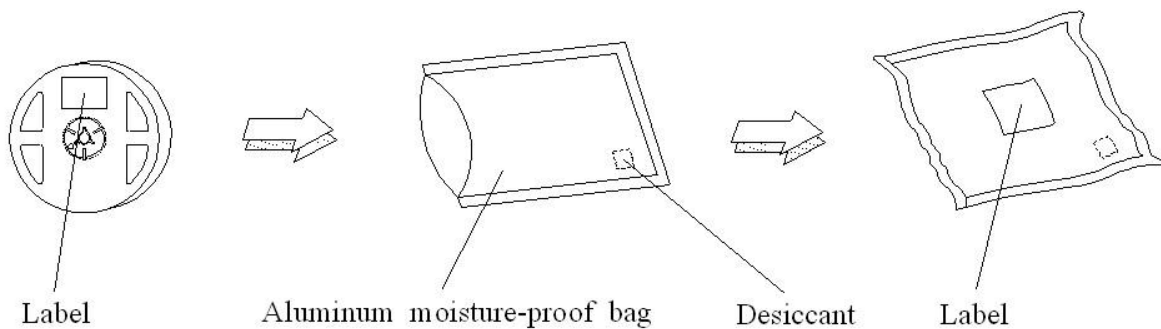

Note:

1. Above specification may be changed without notice. Everlight Americas will reserve authority on material change for above specification.
2. When using this product, please observe the absolute maximum ratings and the instructions for using outlined in these specification sheets. Everlight Americas assumes no responsibility for any damage resulting from use of the product which does not comply with the absolute maximum ratings and the instructions included in these specification sheets.
3. These specification sheets include materials protected under copyright of Everlight Americas Inc. Please don't reproduce or cause anyone to reproduce them without Everlight Americas's consent.