



Chipsmall Limited consists of a professional team with an average of over 10 year of expertise in the distribution of electronic components. Based in Hongkong, we have already established firm and mutual-benefit business relationships with customers from,Europe,America and south Asia,supplying obsolete and hard-to-find components to meet their specific needs.

With the principle of “Quality Parts,Customers Priority,Honest Operation,and Considerate Service”,our business mainly focus on the distribution of electronic components. Line cards we deal with include Microchip,ALPS,ROHM,Xilinx,Pulse,ON,Everlight and Freescale. Main products comprise IC,Modules,Potentiometer,IC Socket,Relay,Connector.Our parts cover such applications as commercial,industrial, and automotives areas.

We are looking forward to setting up business relationship with you and hope to provide you with the best service and solution. Let us make a better world for our industry!



Contact us

Tel: +86-755-8981 8866 Fax: +86-755-8427 6832

Email & Skype: info@chipsmall.com Web: www.chipsmall.com

Address: A1208, Overseas Decoration Building, #122 Zhenhua RD., Futian, Shenzhen, China



EVALUATION BOARD MANUAL

EBSHSN Series

EVALUATION KIT MANUAL

EKSHSN Series

for EYSHSN Series Bluetooth[®] low energy Module

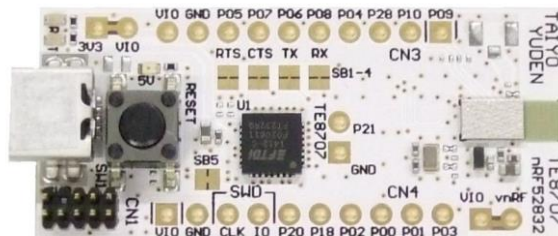

Introduction

This evaluation board is applicable for Taiyo Yuden's **Bluetooth® low energy** module, EYSHSN Series.

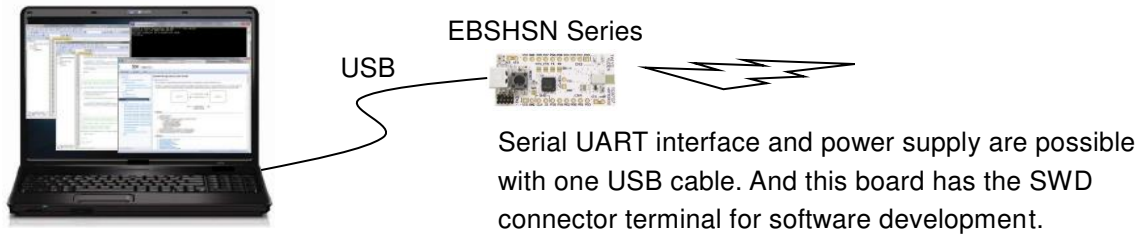

Mounted module

EYSHSN (8.55mm x 3.25mm x 0.85mm_MAX)



Nordic nRF52832 / ARM® Cortex™-M4F 32 bit processor
28-pin Land Grid Array / 15GPIOs / SWD

- Basic Module -

Taiyo Yuden writes firmware for S132 (EYSHSNZWZ) SoftDevice to this product.

The user can develop unique application for the module.

Content

1	EBSHSN Series Evaluation Board	1 pc
2	J-Link Lite (EKSHSN Series Only)	1 set



Evaluation board circuit schematic

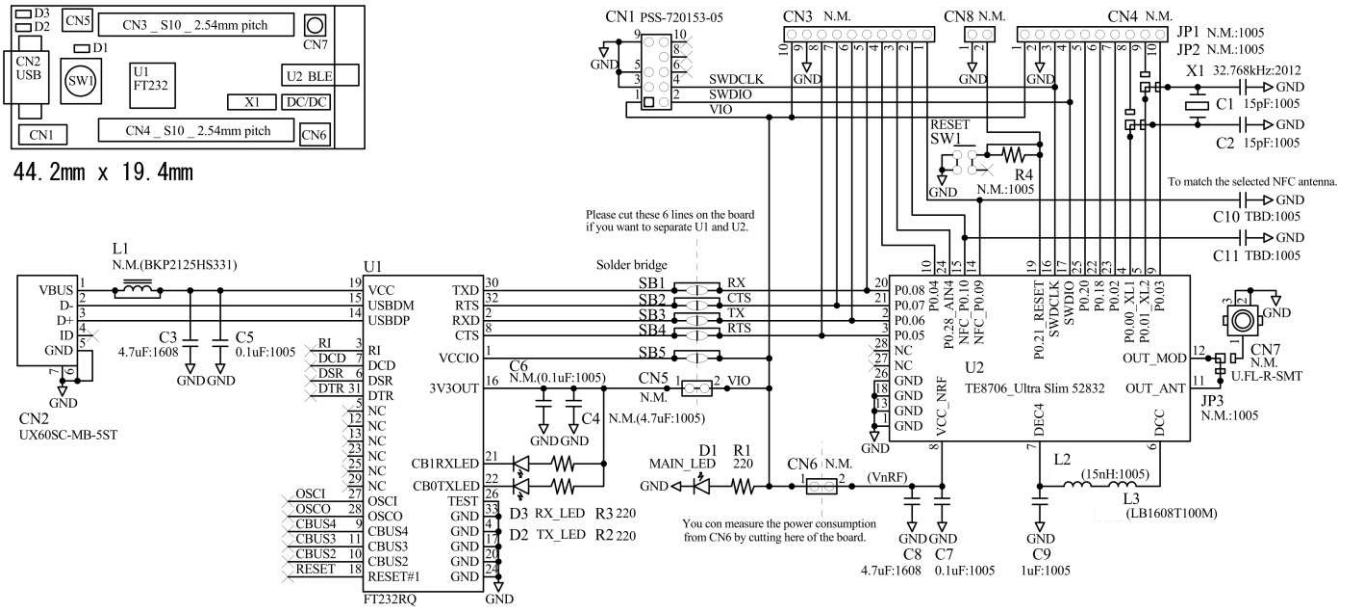

Evaluation board layout

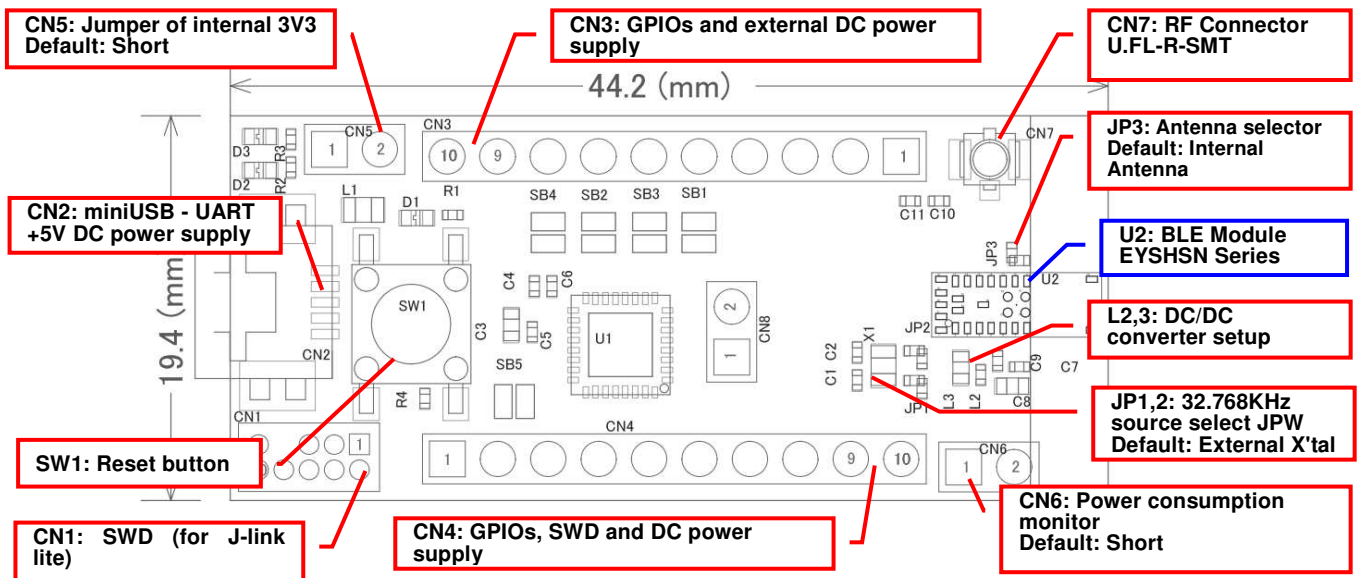

- 1) All pin headers are 2.54mm pitch. And distance between **CN3** and **CN4** is **15.24mm**.
- 2) **CN3-CN8, C4, C6, C10, C11, R4, L1, JP1-JP3, SB1-5** are not mounted (N.M.).
- 3) **D1 (LED):** 3.3V Indicator
- 4) **D2 (LED):** UART TX Indicator
- 5) **D3 (LED):** UART RX Indicator
- 6) **SW1 (Push button):** Module Reset (active low)

Silkscreen Printing

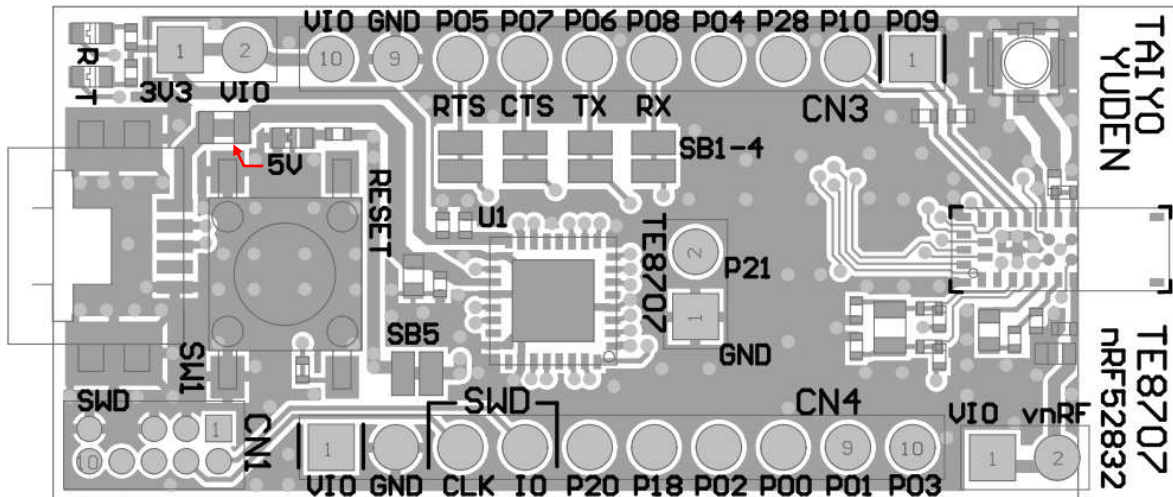

Pin Descriptions

Pin No.	CN3	CN4	CN8
1	NFC/P0.09	VIO	GND
2	NFC/P0.10	GND	P0.21/RESET
3	P0.28	SWDCLK	
4	P0.04	SWDIO	
5	P0.08	P0.20	
6	P0.06	P0.18	
7	P0.07	P0.02	
8	P0.05	P0.00	
9	GND	P0.01	
10	VIO	P0.03	

EBSHSN, EKSHSN

TAIYO YUDEN CO., LTD.

How to use

It is very easy just to tie this board to the PC with a USB cable. It is not necessary to change the setting of the board. The power supply of the module supplies by default 3.3V from 3V3OUT of FT232RQ.

For software development

Nordic-DK and Use case

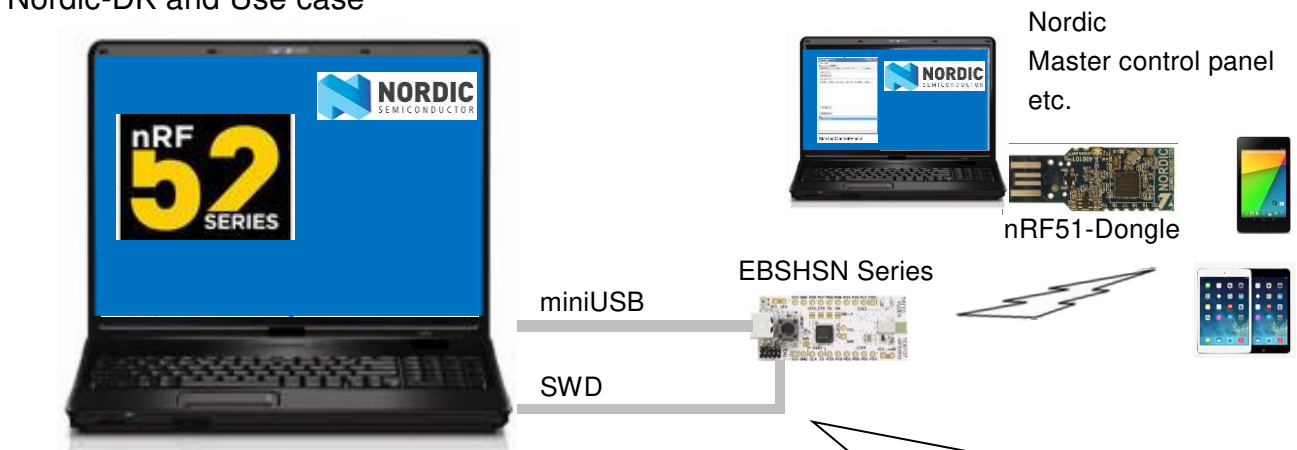

Software Tool



SEGGER Embedded Studio



MDK-ARM Keil uVision5



nRFGo Studio

etc.

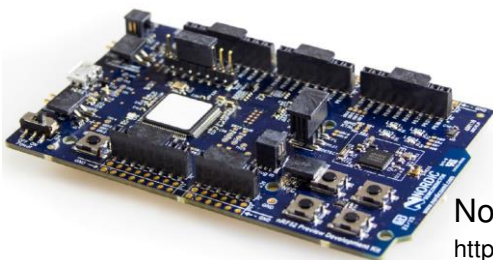

Nordic-DK

<http://www.nordicsemi.com/eng/Products/Bluetooth-low-energy/nRF52-DK>

SWD : Serial Wire Debug
For example, please use J-Link Lite CortexM-9 JTAG/SWD Emulator.
EKSHSNZWZ included



CN1 supports the connection of the 10 pin 1.27 mm flat cable.



Please be careful about the directions.

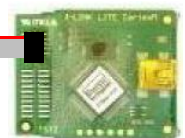

MEMO

1) Current measurement

To measure the current, please cut the shorting 1pin and 2 pin of CN6. And connect an ampere-meter between the pins of connector CN6 to monitor the current directly.

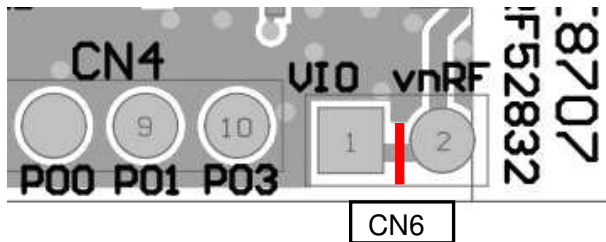

2) About the power supply of the module

When you use external power supply, please supply power from 9pin and 10pin of CN3. On this configuration, you cut short circuit 1pin and 2pin of CN5 and should separate 3V3OUT of FT232RQ.

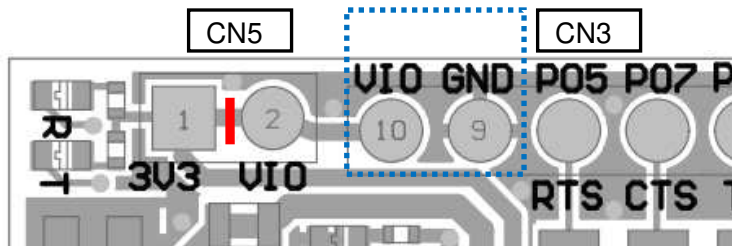

3) USB to serial UART interface

It needs to install driver of FT232RQ to use USB for UART interface. The drivers are available on FTDI website.

<http://www.ftdichip.com/Drivers/D2XX.htm>

In addition, by the application development, please assign GPIO as follows.

GPIO	UART
P0.05	RTS
P0.06	TX
P0.07	CTS
P0.08	RX

4) Size and Coordinate information

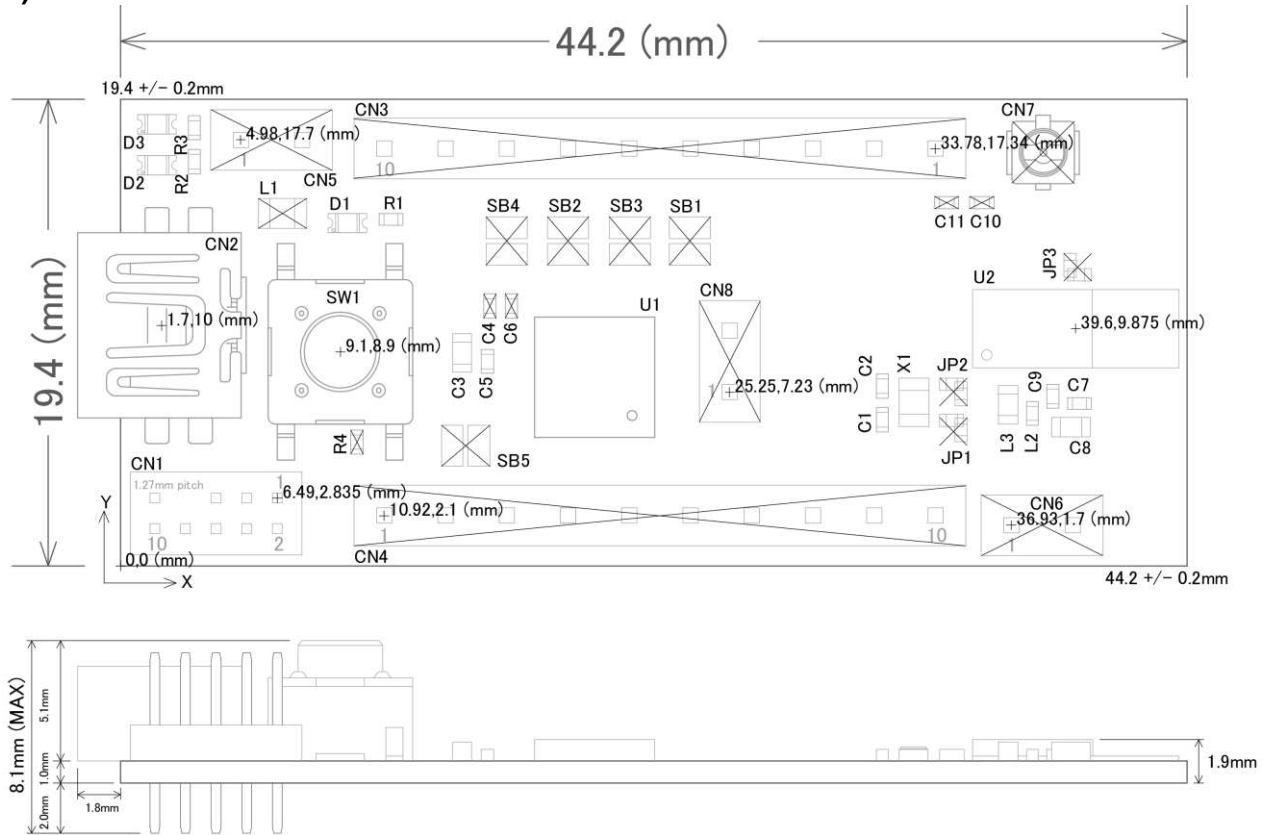

Important notes

32kHz Clock

This module does not installed 32.768kHz crystal. In case of operating without external crystal, please modify sdk_config.h in order to enable internal 32.768kHz RC oscillator (32k RCOSC). The content may change depending on the SDK you use.

--sdk_config.h-- (In case of SDK14.2)

```
// <o> CLOCK_CONFIG_LF_SRC - LF Clock Source
// <0=> RC
// <1=> XTAL
// <2=> Synth
#ifndef CLOCK_CONFIG_LF_SRC
#define CLOCK_CONFIG_LF_SRC 0
#endif

//=====
// <h> Clock - SoftDevice clock configuration
//=====
// <o> NRF_SDH_CLOCK_LF_SRC - SoftDevice clock source.
// <0=> NRF_CLOCK_LF_SRC_RC
// <1=> NRF_CLOCK_LF_SRC_XTAL
// <2=> NRF_CLOCK_LF_SRC_SYNT
#ifndef NRF_SDH_CLOCK_LF_SRC
#define NRF_SDH_CLOCK_LF_SRC 0
#endif

// <o> NRF_SDH_CLOCK_LF_RC_CTIV - SoftDevice calibration timer interval.
#ifndef NRF_SDH_CLOCK_LF_RC_CTIV
#define NRF_SDH_CLOCK_LF_RC_CTIV 16
#endif

// <o> NRF_SDH_CLOCK_LF_RC_TEMP_CTIV - SoftDevice calibration timer interval under constant temperature.
// <i> How often (in number of calibration intervals) the RC oscillator shall be calibrated
// <i> if the temperature has not changed.
#ifndef NRF_SDH_CLOCK_LF_RC_TEMP_CTIV
#define NRF_SDH_CLOCK_LF_RC_TEMP_CTIV 2
#endif

// <o> NRF_SDH_CLOCK_LF_XTAL_ACCURACY - External crystal clock accuracy used in the LL to compute
// timing windows.
// <0=> NRF_CLOCK_LF_XTAL_ACCURACY_250_PPM
// <1=> NRF_CLOCK_LF_XTAL_ACCURACY_500_PPM
// <2=> NRF_CLOCK_LF_XTAL_ACCURACY_150_PPM
// <3=> NRF_CLOCK_LF_XTAL_ACCURACY_100_PPM
// <4=> NRF_CLOCK_LF_XTAL_ACCURACY_75_PPM
// <5=> NRF_CLOCK_LF_XTAL_ACCURACY_50_PPM
// <6=> NRF_CLOCK_LF_XTAL_ACCURACY_30_PPM
// <7=> NRF_CLOCK_LF_XTAL_ACCURACY_20_PPM

#ifndef NRF_SDH_CLOCK_LF_XTAL_ACCURACY
#define NRF_SDH_CLOCK_LF_XTAL_ACCURACY 0
#endif
```

Note that when you choose to use the RC oscillator, it will add around 2uA average current consumption compared to a 20ppm external crystal.

ANT specification requires +/-50ppm accuracy for 32.768kHz clock. There is a possibility that the internal RC oscillator does not meet to the specification.