



Chipsmall Limited consists of a professional team with an average of over 10 year of expertise in the distribution of electronic components. Based in Hongkong, we have already established firm and mutual-benefit business relationships with customers from,Europe,America and south Asia,supplying obsolete and hard-to-find components to meet their specific needs.

With the principle of “Quality Parts,Customers Priority,Honest Operation,and Considerate Service”,our business mainly focus on the distribution of electronic components. Line cards we deal with include Microchip,ALPS,ROHM,Xilinx,Pulse,ON,Everlight and Freescale. Main products comprise IC,Modules,Potentiometer,IC Socket,Relay,Connector.Our parts cover such applications as commercial,industrial, and automotives areas.

We are looking forward to setting up business relationship with you and hope to provide you with the best service and solution. Let us make a better world for our industry!



Contact us

Tel: +86-755-8981 8866 Fax: +86-755-8427 6832

Email & Skype: info@chipsmall.com Web: www.chipsmall.com

Address: A1208, Overseas Decoration Building, #122 Zhenhua RD., Futian, Shenzhen, China



EC-23097-000
SHT 1.1

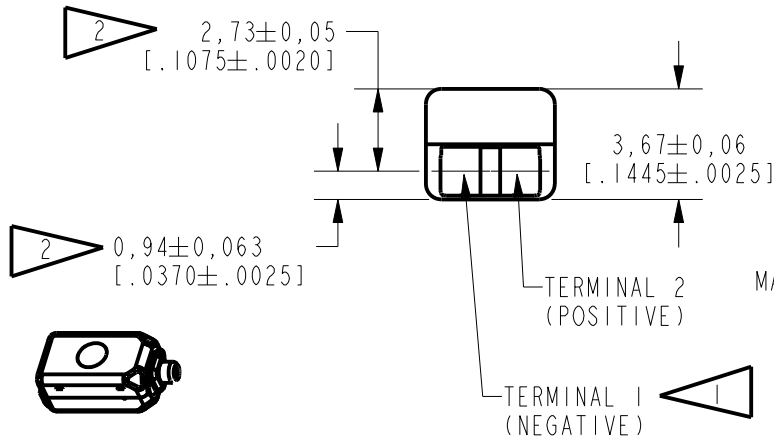
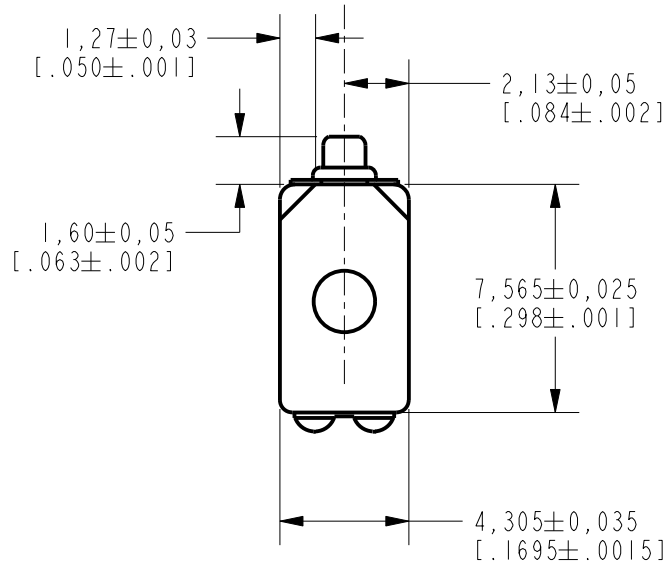

SCALE 2:1
NOMINAL WEIGHT
.42 GRAMS

DIMENSIONS IN MILLIMETERS [INCHES]

NOTES:

- 1 A POSITIVE GOING VOLTAGE AT TERMINAL 2, RELATIVE TO TERMINAL 1, CAUSES A DECREASE IN PRESSURE AT THE SOUND OUTLET.
- 2 LOCATED FROM TWO SURFACES FOR CUSTOMER CONVENIENCE. ONLY APPLICABLE FROM ONE SURFACE, NOT TO BE USED TOGETHER.

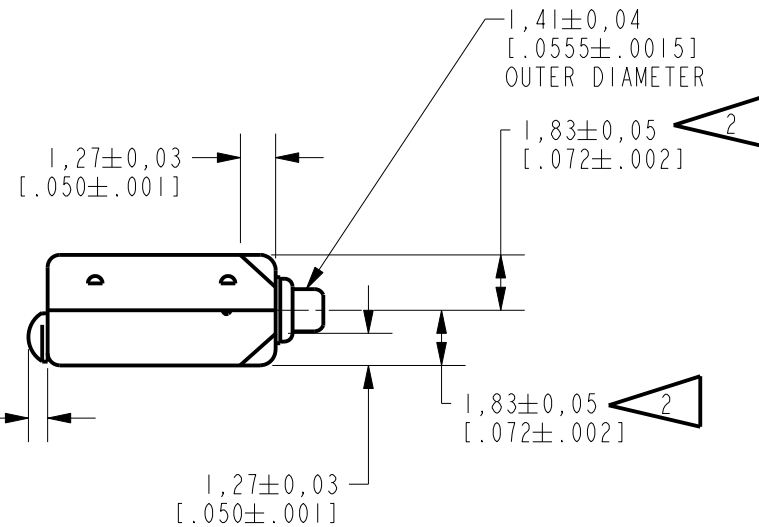

Revision	C.O. #	Implementation Date	RELEASE LEVEL	REVISION
C	CI0115009	7-11-13	Active	C
B	CI0106330	9-3-07		
A	CI0103434	11-15-05		

SCALE: 4:1		DR. BY	DATE
DO NOT SCALE DRAWING		CRG	11-15-05
TITLE: RECEIVER		EC-23097-000	GJP 11-22-05
OUTLINE DRAWING		SHT 1.1	APP. BY DATE GJP 11-22-05

KNOWLES ELECTRONICS
ITASCA, ILLINOIS U.S.A.

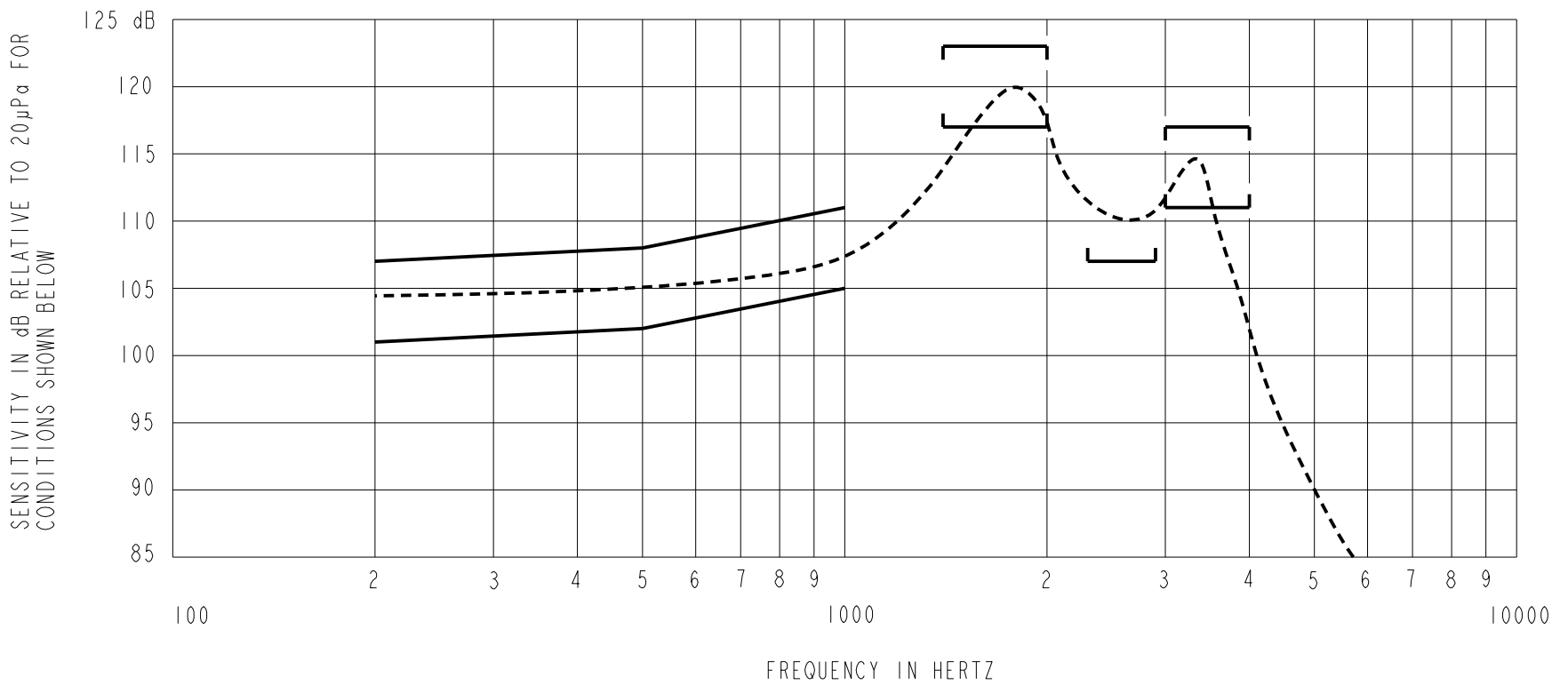

NOTES:

1. MEASUREMENTS MADE USING 10mm (.394") OF 1mm (.039") ID TUBE CONNECTED TO A SIMULATED ANSI S3.7 TYPE HA-3 COUPLER . (IEC 60318-5).

2. SENSITIVITY

FREQUENCY	MIN.	MAX.
200	101.0	107.0
500	102.0	108.0
1000	105.0	111.0
1400-2000	117.0	123.0
2300-2900	107.0	---
3000-4000	111.0	117.0

3. RESPONSE, IMPEDANCE, AND DISTORTION MEASUREMENTS MADE USING THE ELECTRICAL TEST CONDITIONS SHOWN BELOW.
 4. ELECTRICAL SOURCE IMPEDANCE MUST BE GREATER THAN 20 TIMES 1KHz IMPEDANCE FOR TEST CONDITIONS SHOWN BELOW.
 5. INDIVIDUAL SPECIFICATIONS:

PORT LOCATION	IMPEDANCE OHMS ±15%		DCR @20°C OHMS ±10%	DISTORTION		ELECTRICAL TEST CONDITIONS	
	1KHz	500Hz		MAX. %	FREQ Hz	AC mA RMS	DC mA
12S	400	200	92.0	10	800	1.09	1.55

Revision	C.O. #	Implementation Date	RELEASE LEVEL	REVISION
C	C10115009	7-11-13	Active	C
B	C10106330	9-3-07		
A	C10103434	11-15-05		

KNOWLES ELECTRONICS
 ITASCA, ILLINOIS U.S.A.

WHEN TEST LIMITS ARE USED TO ESTABLISH INCOMING INSPECTION ACCEPTANCE/REJECTION CRITERIA, CORRELATION OF TEST EQUIPMENT WITH KNOWLES IS ALSO REQUIRED FOR ELIMINATION OF EQUIPMENT AND TEST METHOD VARIATION

TITLE: **RECEIVER** **EC-23097-000**
 PERFORMANCE SPECIFICATION **SHT 2.1**

DR. BY	DATE
CRG	11-15-05
CK. BY	DATE
GJP	11-22-05
APP. BY	DATE
GJP	11-22-05