



Chipsmall Limited consists of a professional team with an average of over 10 year of expertise in the distribution of electronic components. Based in Hongkong, we have already established firm and mutual-benefit business relationships with customers from,Europe,America and south Asia,supplying obsolete and hard-to-find components to meet their specific needs.

With the principle of “Quality Parts,Customers Priority,Honest Operation,and Considerate Service”,our business mainly focus on the distribution of electronic components. Line cards we deal with include Microchip,ALPS,ROHM,Xilinx,Pulse,ON,Everlight and Freescale. Main products comprise IC,Modules,Potentiometer,IC Socket,Relay,Connector.Our parts cover such applications as commercial,industrial, and automotives areas.

We are looking forward to setting up business relationship with you and hope to provide you with the best service and solution. Let us make a better world for our industry!



## Contact us

Tel: +86-755-8981 8866 Fax: +86-755-8427 6832

Email & Skype: info@chipsmall.com Web: www.chipsmall.com

Address: A1208, Overseas Decoration Building, #122 Zhenhua RD., Futian, Shenzhen, China



### PROTECTION PRODUCTS - EMIClamp™

#### Description

The EClamp™2522P is an easily implemented solution for protection and termination of low speed or full speed Universal Serial Bus (USB) ports. Each device will provide termination, filtering, and ESD protection for one upstream USB port on cellular phones and other portable electronics. This state-of-the-art device utilizes solid-state silicon-avalanche technology for superior clamping performance and electrical characteristics.

Line termination is achieved with 22 Ohm series resistors on both the D+ and D- USB lines. TVS diodes are also included on each data line for ESD protection in excess of  $\pm 15\text{kV}$  (air discharge) and  $\pm 8\text{kV}$  (contact discharge) per IEC 61000-4-2, level 4. An additional TVS diode connection is included for protection of the voltage (VBus) bus. The 1.5k Ohm pull-up resistor is included on one of the USB data lines to identify the equipment as either a full-speed (connected to D+ line) or low-speed (connected to D- line) device.

The EClamp2522P is in a 6-pin, RoHS compliant, SLP1616P6 package. It measures 1.6 x 1.6 x 0.60mm. The leads are spaced at a pitch of 0.5mm and are finished with lead-free NiPdAu. The small package makes it ideal for use in portable electronics such as cell phones and digital still cameras.

#### Circuit Diagram

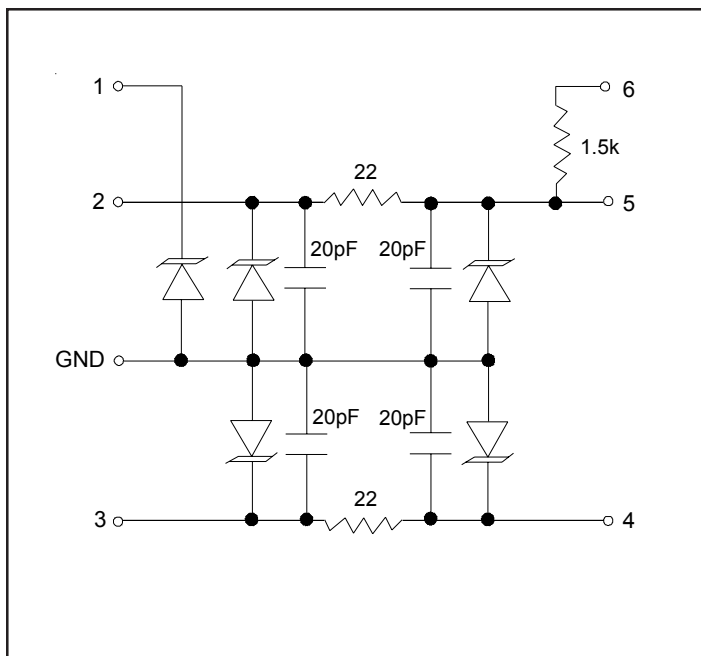

#### Features

- ◆ Bidirectional EMI/RFI filter with integrated TVS for ESD protection
- ◆ ESD protection to **IEC 61000-4-2 (ESD) Level 4,  $\pm 15\text{kV}$  (air),  $\pm 8\text{kV}$  (contact)**
- ◆ TVS working voltage: 5.25V
- ◆ Termination Resistor: 22 Ohms
- ◆ Capacitance: 45pF (Max at VR = 0V)
- ◆ Protection and filtering for one USB port
- ◆ Solid-state technology

#### Mechanical Characteristics

- ◆ SLP1616P6 6L package
- ◆ RoHS/WEEE Compliant
- ◆ Nominal Dimensions: 1.6 x 1.6 x 0.60 mm
- ◆ Lead Finish: NiPdAu
- ◆ Molding compound flammability rating: UL 94V-0
- ◆ Marking : Marking code + date code
- ◆ Packaging : Tape and Reel per EIA 481

#### Applications

- ◆ USB Ports
- ◆ Cellular Handsets
- ◆ PDAs
- ◆ PC Peripherals
- ◆ MP3 Players

#### Pin Configuration

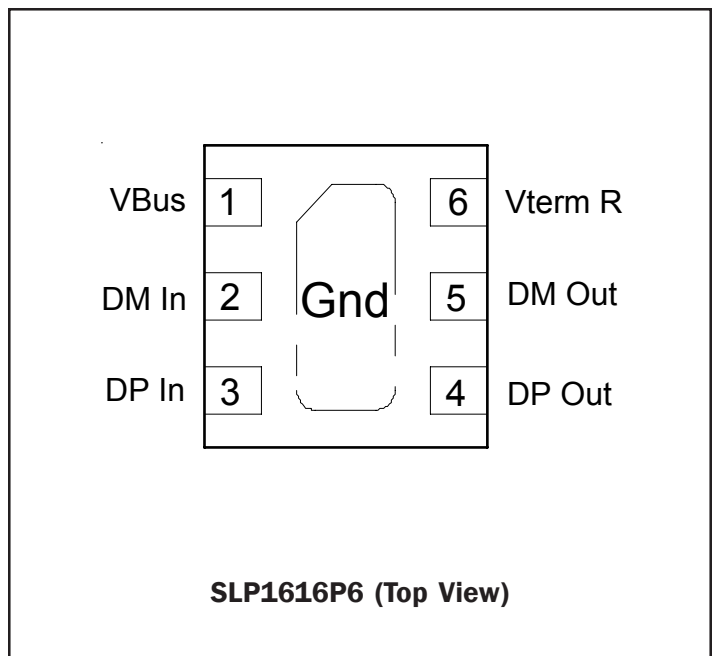

## PROTECTION PRODUCTS

### Maximum Ratings

Rating	Symbol	Value	Units
ESD per IEC 61000-4-2 (Air) ESD per IEC 61000-4-2 (Contact)	$V_{ESD}$	+/- 17 +/- 12	kV
Junction Temperature	$T_J$	125	°C
Operating Temperature	$T_{op}$	-40 to +85	°C
Storage Temperature	$T_{STG}$	-55 to +150	°C

### Electrical Characteristics (T=25°C)

Parameter	Symbol	Conditions	Minimum	Typical	Maximum	Units
TVS Reverse Stand-Off Voltage	$V_{RWM}$	Pin 1 to GND			5.5	V
TVS Reverse Breakdown Voltage	$V_{BR}$	Pin 1 to GND $I_t = 1mA$	6	7.5	9	V
TVS Reverse Leakage Current	$I_R$	$V_{RWM} = 5.5V$ Between data (D+, D-) pin and Ground			1	μA
TVS Reverse Leakage Current	$I_R$	Each Line			1	μA
Series Resistance	$R_S$	Each Line	20	22	24	Ohms
Pull Up Resistance	$R_{PU}$		1.35	1.5	1.65	kOhms
Total Capacitance	$C_{TOT}$	Pin 1, 2 or 3 to GND $V_R = 0V, f = 1MHz$	30	40	45	pF



## PROTECTION PRODUCTS

### Typical Characteristics

#### Typical Insertion Loss S21

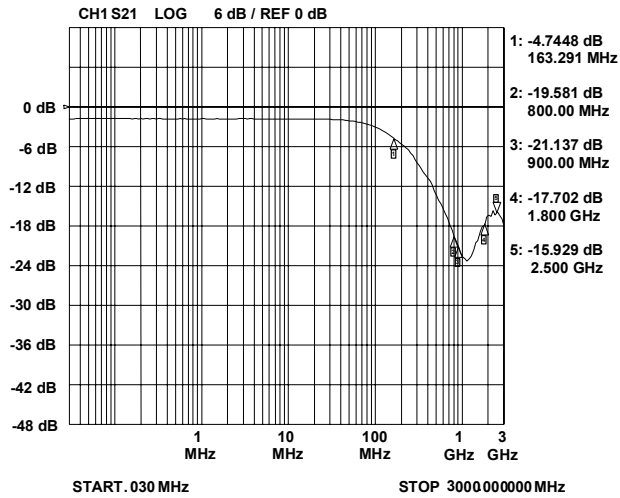

#### Analog Crosstalk (Each Line)

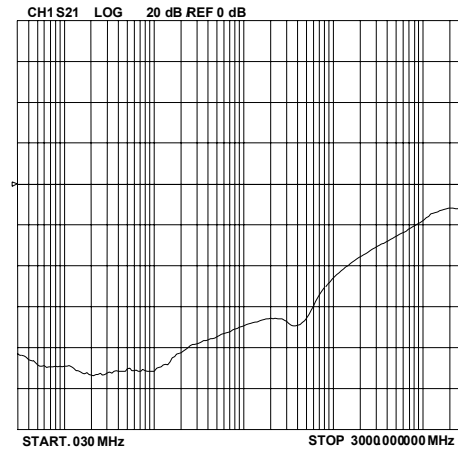

#### ESD Clamping (+8kV Contact)

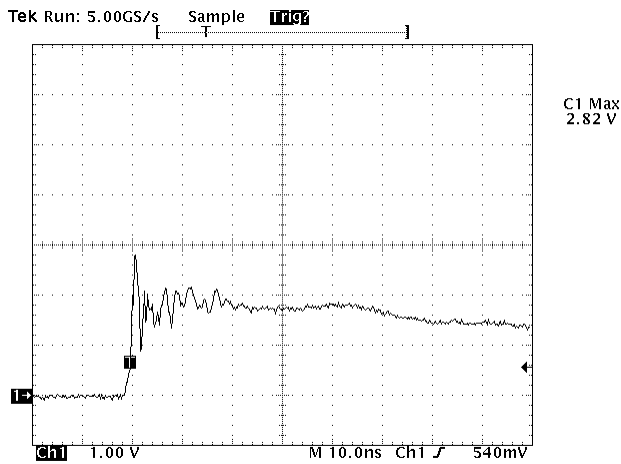

Note: Data is taken with a 10x attenuator

#### ESD Clamping (-8kV Contact)

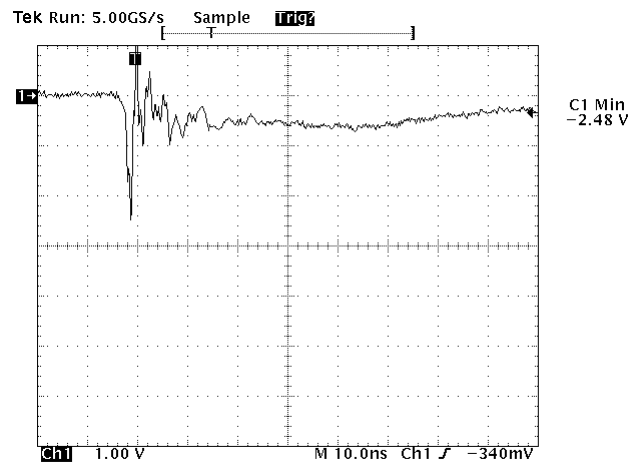

Note: Data is taken with a 10x attenuator

#### Normalized Capacitance vs. Reverse Voltage

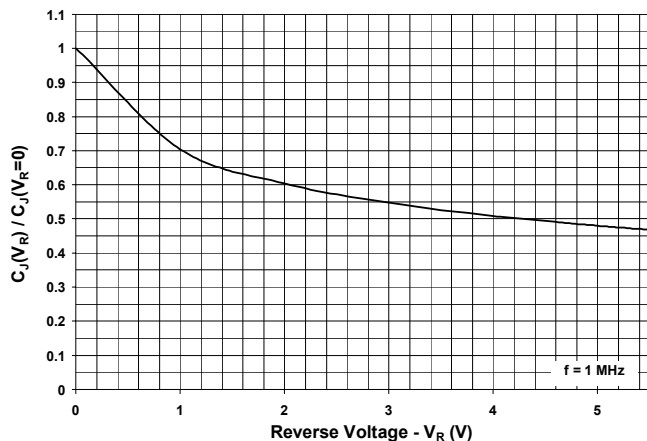

## PROTECTION PRODUCTS

### Device Connection

The EClamp2522P is designed to provide termination, EMI filtering and ESD protection for one USB port. The device is connected as follows:

- 1. Full-Speed Devices:** For full-speed devices the pull-up resistor is connected to the D+ line. Route the D+ line from the connector to pin 2. Pin 5 is connected to the D+ line of the IC. Route the D- line from the connector to pin 3. Pin 4 is connected to the D- line of the IC. Pin 1 is connected to the voltage supply line ( $V_{BUS}$ ). Pin 6 is connected to the 3.3 Volt supply. The ground connection is made to the center tab. For best results, use multiple vias to the ground plane to reduce parasitic inductance.
- 2. Low-Speed Devices:** For low speed devices the pull-up resistor is connected to the D- line. Route the D- line from the connector to pin 2. Pin 5 is connected to the D- line of the IC. Route the D+ line from the connector to pin 3. Pin 4 is connected to the D+ line of the IC. Pin 1 is connected to the voltage supply line ( $V_{BUS}$ ). Pin 6 is connected to the 3.3 Volt supply. The ground connection is made to the center tab. For best results, use multiple vias to the ground plane to reduce parasitic inductance.

### USB Port Design Considerations

The Universal Serial Bus (USB) specification requires termination and filtering components for proper operation. In addition, an open USB socket is vulnerable to hazardous ESD discharges in excess of 15kV. These discharges can occur on the data lines or the voltage bus. The EClamp2522P is an easily implemented solution that is designed to meet the termination and EMI filter requirements of the USB specification for low speed and full speed devices. It also provides ESD protection to IEC 61000-4-2, level 4.

USB line termination is achieved with series resistors on both the D+ and D- lines. These resistors preserve signal integrity by matching the cable impedance to that of the differential driver. A 1.5k $\Omega$  pull-up resistor is used to identify an upstream port on either the D+ (full speed devices) or the D- (low speed devices) data line. TVS diodes provide ESD protection of both (D+ and D-) data lines and the voltage bus ( $V_{BUS}$ ). This integrated solution simplifies design and requires minimal board space.

**Figure 1 - Pin Identification and Configuration (Top Side View)**

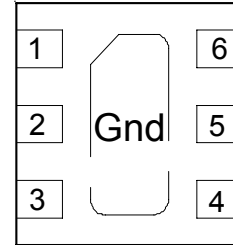

Pin	Symbol	Identification
1	VBus	5.25V VBus ESD Protection
2	DM In	USB data input with termination resistor
3	DP In	USB data input with termination resistor
4	DP Out	USB data output with termination resistor
5	DM Out	USB data output with termination resistor
6	$V_{Term}$	1.5k Ohm pull-up resistor
Center Tab	GND	Ground connection

## PROTECTION PRODUCTS

### Applications Information - Spice Model

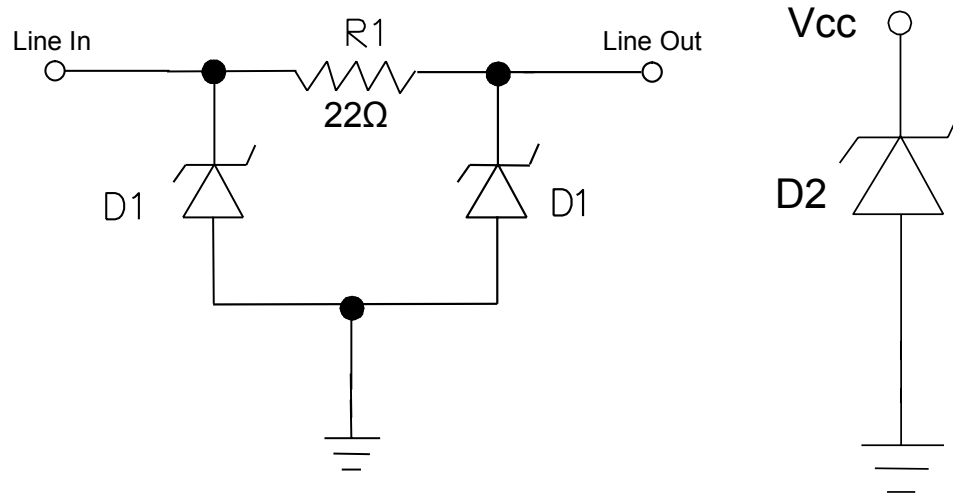

**EClamp2522P Spice Model**

EClamp2522P Spice Parameters			
Parameter	Unit	D1	D2
IS	Amp	3.4E-15	3.4E-15
BV	Volt	7.546	7.594
VJ	Volt	0.753	0.753
RS	Ohm	0.649	0.441
IBV	Amp	1E-3	1E-3
CJO	Farad	17E-12	31E-12
TT	sec	2.541E-9	2.541E-9
M	--	0.24	0.26
N	--	1.1	1.1
EG	eV	1.11	1.11

## PROTECTION PRODUCTS

### Outline Drawing - SLP1616P6

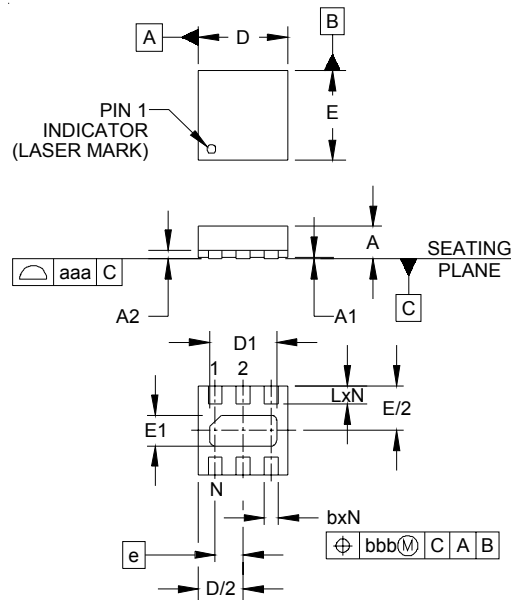

DIM	DIMENSIONS					
	INCHES			MILLIMETERS		
	MIN	NOM	MAX	MIN	NOM	MAX
A	.020	.023	.026	0.50	0.58	0.65
A1	0.00	.001	.002	0.00	0.03	0.05
A2	(.006)			(.15)		
b	.007	.010	.012	0.20	0.25	0.30
D	.059	.063	.067	1.50	1.60	1.70
D1	.041	.047	.051	1.05	1.20	1.30
E	.059	.063	.067	1.50	1.60	1.70
E1	.016	.022	.026	0.40	0.55	0.65
e	.020 BSC			0.50 BSC		
L	.013	.013	.016	0.25	0.33	0.40
N	6			6		
aaa	.004			0.09		
bbb	.004			0.09		

**NOTES:**

1. CONTROLLING DIMENSIONS ARE IN MILLIMETERS (ANGLES IN DEGREES).
2. COPLANARITY APPLIES TO THE EXPOSED PAD AS WELL AS THE TERMINALS.

### Land Pattern - SLP1616P6

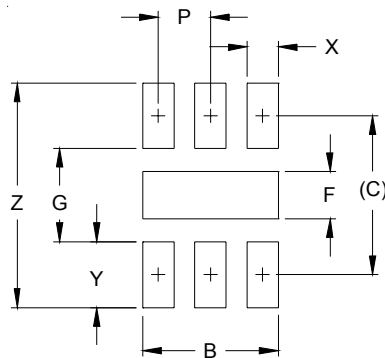

DIM	DIMENSIONS	
	INCHES	MILLIMETERS
B	.051	1.30
C	.060	1.52
P	.020	0.50
F	.018	0.45
G	.035	0.89
X	.012	0.30
Y	.025	0.63
Z	.085	2.15

**NOTES:**

1. THIS LAND PATTERN IS FOR REFERENCE PURPOSES ONLY. CONSULT YOUR MANUFACTURING GROUP TO ENSURE YOUR COMPANY'S MANUFACTURING GUIDELINES ARE MET.

## PROTECTION PRODUCTS

### Marking

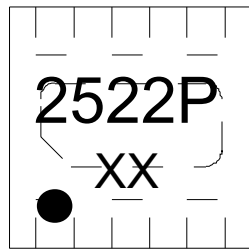

XX = Date Code

### Ordering Information

Part Number	Qty per Reel	Reel Size
EClamp2522P.TCT	3000	7 Inch

This is a lead-free RoHS/WEEE Compliant Device  
EMIClamp and EClamp are marks of Semtech Corporation

### Tape and Reel Specification

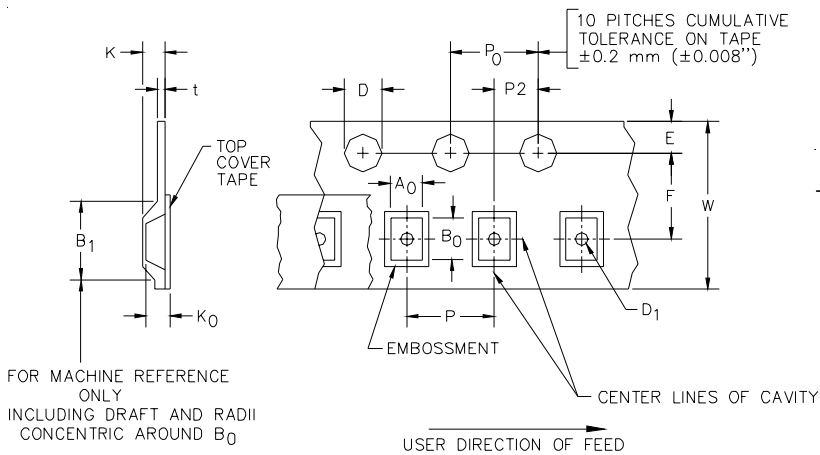

#### Pin 1 Location

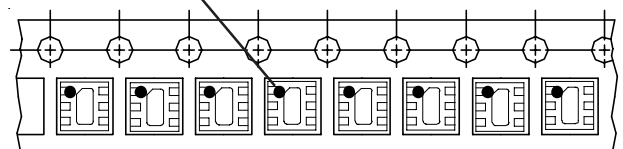

**Device Orientation in Tape**  
**Pin 1 in upper left towards sprocket holes**

A0	B0	K0
1.78 +/-0.05 mm	1.78 +/-0.05 mm	0.69 +/-0.05 mm

Tape Width	B, (Max)	D	D1	E	F	K (MAX)	P	P0	P2	T(MAX)	W
8 mm	4.2 mm	1.5 + 0.1 mm - 0.0 mm )	0.5 mm ±0.05	1.750±.10 mm	3.5±0.05 mm	2.4 mm	4.0±0.1 mm	4.0±0.1 mm	2.0±0.05 mm	0.4 mm	8.0 mm + 0.3 mm - 0.1 mm

### Contact Information

Semtech Corporation  
Protection Products Division  
200 Flynn Rd., Camarillo, CA 93012  
Phone: (805)498-2111 FAX (805)498-3804