



Chipsmall Limited consists of a professional team with an average of over 10 year of expertise in the distribution of electronic components. Based in Hongkong, we have already established firm and mutual-benefit business relationships with customers from,Europe,America and south Asia,supplying obsolete and hard-to-find components to meet their specific needs.

With the principle of "Quality Parts,Customers Priority,Honest Operation,and Considerate Service",our business mainly focus on the distribution of electronic components. Line cards we deal with include Microchip,ALPS,ROHM,Xilinx,Pulse,ON,Everlight and Freescale. Main products comprise IC,Modules,Potentiometer,IC Socket,Relay,Connector.Our parts cover such applications as commercial,industrial, and automotives areas.

We are looking forward to setting up business relationship with you and hope to provide you with the best service and solution. Let us make a better world for our industry!



Contact us

Tel: +86-755-8981 8866 Fax: +86-755-8427 6832

Email & Skype: info@chipsmall.com Web: www.chipsmall.com

Address: A1208, Overseas Decoration Building, #122 Zhenhua RD., Futian, Shenzhen, China



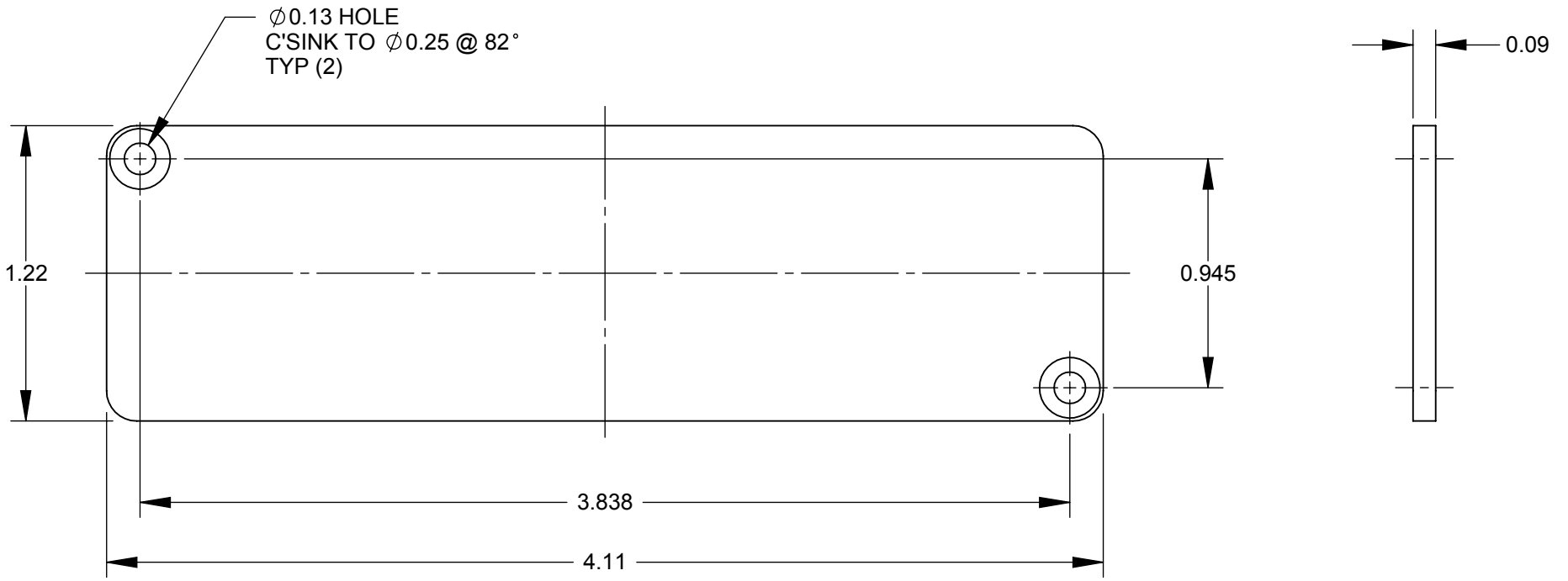

NOTES:

1. MATERIAL: ALUMINUM, BLACK ANODIZE
2. SUPPLIED WITH (2) #4-40 MOUNTING SCREWS - STEEL, BLACK OXIDE.
3. THIS PRODUCT IS RoHS COMPLIANT.

CUSTOMER DRAWING

					THIS DRAWING DESCRIBES A DESIGN CONSIDERED PROPRIETARY IN NATURE, DEVELOPED AND MANUFACTURED BY SWITCHCRAFT INC. AND IS RELEASED ON A CONFIDENTIAL BASIS FOR IDENTIFICATION PURPOSES ONLY.					
					SIZE	WIDTH	MULT	LBS/M	TEMPER	
					FINISH			MATERIAL		
					SPEC No.			SPEC No.		
					FIRST USED ON		SCALE			
							2:1			
					DATE DRAWN	BY	CHKD	APVD		
					08-16-11	JEB	JEB	TJK		
							08-16-11	08-16-11		
					Switchcraft®					
					SHEET 1 OF 1					
					NAME				PART No.	REV
					QG 4 HOLE COVER, RoHS				ECP4PKG	A
REVISIONS					DO NOT SCALE DRAWING					

