



Chipsmall Limited consists of a professional team with an average of over 10 year of expertise in the distribution of electronic components. Based in Hongkong, we have already established firm and mutual-benefit business relationships with customers from,Europe,America and south Asia,supplying obsolete and hard-to-find components to meet their specific needs.

With the principle of "Quality Parts,Customers Priority,Honest Operation,and Considerate Service",our business mainly focus on the distribution of electronic components. Line cards we deal with include Microchip,ALPS,ROHM,Xilinx,Pulse,ON,Everlight and Freescale. Main products comprise IC,Modules,Potentiometer,IC Socket,Relay,Connector.Our parts cover such applications as commercial,industrial, and automotives areas.

We are looking forward to setting up business relationship with you and hope to provide you with the best service and solution. Let us make a better world for our industry!



Contact us

Tel: +86-755-8981 8866 Fax: +86-755-8427 6832

Email & Skype: info@chipsmall.com Web: www.chipsmall.com

Address: A1208, Overseas Decoration Building, #122 Zhenhua RD., Futian, Shenzhen, China



ENERGIZER NO. CR2012

Lithium Coin



Industry Standard Dimensions
mm (inches)



This Battery has Underwriters Laboratories component Recognition

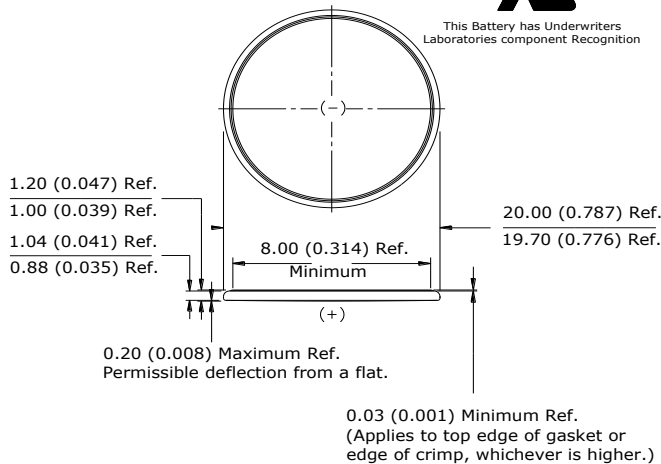

Simulated Application test

Typical Performance at 21°C (70°F)

Schedule:	Typical Drains: at 2.9V (mA)	Load (ohms)	Cutoff 2.0V (hours)
Continuous	0.097	30,000	598

Typical Discharge Characteristics

Load: 30K ohms - Continuous
Typical Drain @ 2.9V: 0.097 mA

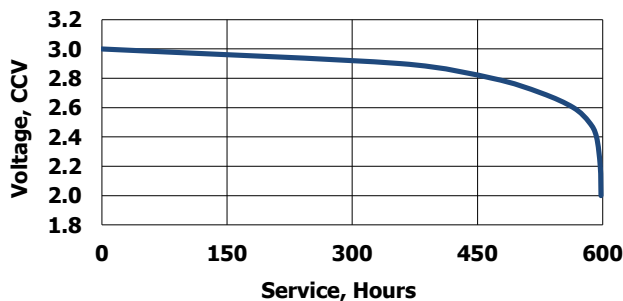

Internal Resistance Characteristics

Pulse Test at 21°C (70°F)

Bkgnd Drain: Continuous
30K ohms
0.097 mA @2.9V

Pulse Drain: 2 seconds X 12 times/day
400 ohms
6.8 mA @2.7V

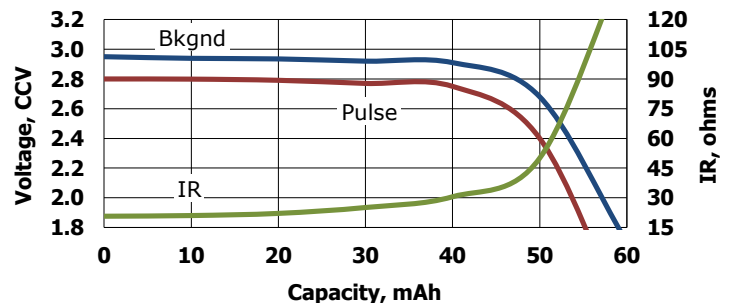

Important Notice

This datasheet contains typical information specific to products manufactured at the time of its publication.
©Energizer Holdings, Inc. - Contents herein do not constitute a warranty.

Specifications

Classification: "Lithium Coin"
Chemical System: Lithium / Manganese Dioxide (Li/MnO₂)
Nominal Voltage: 3.0 Volts
Typical Capacity: 58 mAh (to 2.0 volts)
(Rated at 30K ohms at 21°C)
Typical Weight: 1.3 grams (0.04 oz.)
Typical Volume: 0.3 cubic centimeters (0.02 cubic inch)
Max Rev Charge: 1 microampere
Energy Density: 129 milliwatt hr/g, 561 milliwatt hr/cc
Typical Li Content: 0.017 grams (0.0006 oz.)
UL Listed: MH12454

Safety:



(1) KEEP OUT OF REACH OF CHILDREN. Swallowing may lead to serious injury or death in as little as 2 hours due to chemical burns and potential perforation of the esophagus. **Immediately see doctor; have doctor phone (202) 625-3333.**

(2) Battery compartment design. To prevent children from removing batteries, battery compartments should be designed with one of the following methods: a) a tool such as screwdriver or coin is required to open battery compartment or b) the battery compartment door/cover requires the application of a minimum of two independent and simultaneous movements of the securing mechanism to open by hand. Screws should remain captive with the battery door or cover.