



Chipsmall Limited consists of a professional team with an average of over 10 year of expertise in the distribution of electronic components. Based in Hongkong, we have already established firm and mutual-benefit business relationships with customers from,Europe,America and south Asia,supplying obsolete and hard-to-find components to meet their specific needs.

With the principle of "Quality Parts,Customers Priority,Honest Operation,and Considerate Service",our business mainly focus on the distribution of electronic components. Line cards we deal with include Microchip,ALPS,ROHM,Xilinx,Pulse,ON,Everlight and Freescale. Main products comprise IC,Modules,Potentiometer,IC Socket,Relay,Connector.Our parts cover such applications as commercial,industrial, and automotives areas.

We are looking forward to setting up business relationship with you and hope to provide you with the best service and solution. Let us make a better world for our industry!



Contact us

Tel: +86-755-8981 8866 Fax: +86-755-8427 6832

Email & Skype: info@chipsmall.com Web: www.chipsmall.com

Address: A1208, Overseas Decoration Building, #122 Zhenhua RD., Futian, Shenzhen, China



REVISIONS			
REV	DESCRIPTION	DATE	APPROVED

ELECTRICAL SPECIFICATIONS

Frequency: 1.000 MHz
 Frequency Tolerance (Ref @ +25°C): ± 100 ppm Max.
 Frequency Stability (0 to +60°C): ± 100 ppm Max.
 Crystal Cut: SL
 Load Capacitance (CL): 13 pF
 Recommended Drive Level: 500 µW Max.
 Effective Series Resistance: 3000 Ω Max.
 Insulation Resistance: 500 Megaohms Min. @ 100 Vdc
 Shunt Capacitance: 7 pF Max.
 Mode of Operation: Fundamental
 Aging: ± 10 ppm/year Max.
 Storage Temperature: -30 to +85°C
 Operating Temperature: 0 to +60°C
 Package Type: HC-49U

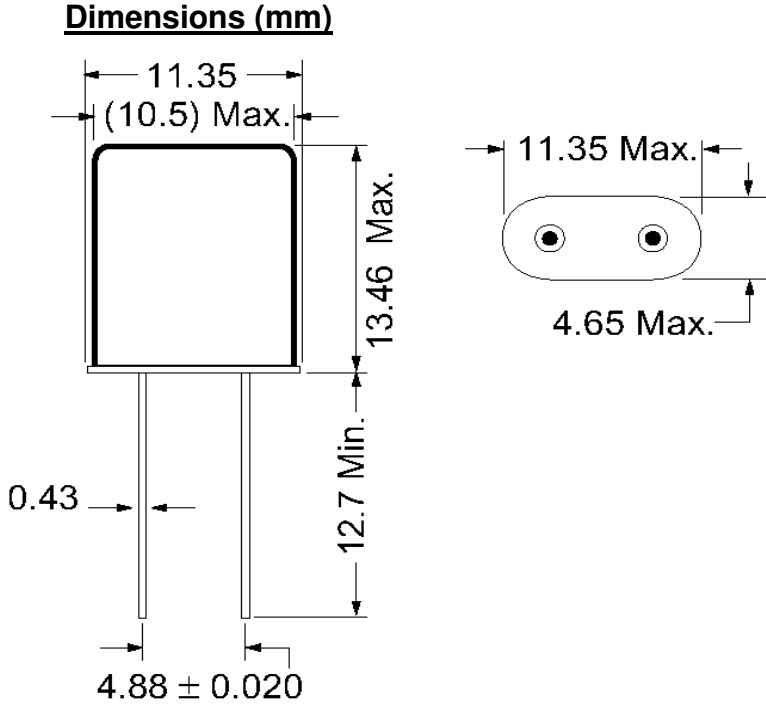

Figure 1) Side and bottom view

ECS Part Number: ECS-10-13-1H

ECS INC. INTERNATIONAL 1105 S. Ridgeview Olathe, KS 66062 (913) 782-7787			
SIGNATURES		DATE	
DRN	BL	11/24/1998	
CHK	DK	11/24/1998	
APP	BS	11/24/1998	
TITLE		1.000 MHz Crystal, HC-49U 13 pF Load Capacitance, SL Cut	
SIZE	DWG NO.	REV	
A	ECS-10-13-1H	-	
CAGE CODE: 1G8B7		SHEET 1 OF 1	

SIGNATURES		DATE	
DRN	BL	11/24/1998	
CHK	DK	11/24/1998	
APP	BS	11/24/1998	
Dimensions in mm			