



Chipsmall Limited consists of a professional team with an average of over 10 year of expertise in the distribution of electronic components. Based in Hongkong, we have already established firm and mutual-benefit business relationships with customers from,Europe,America and south Asia,supplying obsolete and hard-to-find components to meet their specific needs.

With the principle of “Quality Parts,Customers Priority,Honest Operation,and Considerate Service”,our business mainly focus on the distribution of electronic components. Line cards we deal with include Microchip,ALPS,ROHM,Xilinx,Pulse,ON,Everlight and Freescale. Main products comprise IC,Modules,Potentiometer,IC Socket,Relay,Connector.Our parts cover such applications as commercial,industrial, and automotives areas.

We are looking forward to setting up business relationship with you and hope to provide you with the best service and solution. Let us make a better world for our industry!



Contact us

Tel: +86-755-8981 8866 Fax: +86-755-8427 6832

Email & Skype: info@chipsmall.com Web: www.chipsmall.com

Address: A1208, Overseas Decoration Building, #122 Zhenhua RD., Futian, Shenzhen, China



EDM2-WIZARD



Main Features

- The official EDM type 2 Evaluation Carrier Board brings you a rich variety of interfaces and options at your fingertips.
- Wide range of jumper selectable audio, video and touch interfaces.
- Optional smart battery pack implementation.



Power 5 VDC	LAN	LVDS	HDMI	PCIe x4	SATA 2 nd	LPC	HDA	SPDIF	CANBus x2	SD	SPI x2	UART x2	Buttons + GPIO	RSVD
		LVDS	HDMI	PCIe x2	SATA 1 st	USB OTG	USB Host	I ² S 1 st				I ² C x2		

Specifications

Core System

System on Module EDM Type 2 compliant

Expansion

Expansion Slots
 2x mini-PCIe + SIM cardslot (for 3G communication)
 1x PCIe x1 expansion slot (shared with mini-PCIe)
 1x PCIe x4 expansion slot

I/O Interfaces

Connector
 2x SATA
 1x SD cardslot (SDIO)
 1x Gigabit LAN
 2x USB 3.0 Host
 1x micro USB 3.0 / 2.0 OTG
 1x UART (RS-232/422/485)
 2x CAN Bus

Header
 1x UART (RS-232/422/485)
 2x SPI
 8x GPIO (shared with buttons)
 2x I²C
 Manufacturing pins

Video

Connector
 2x HDMI
 2 channel LVDS 18/24 bit

Audio

Codec
 Jumper selectable:
 Freescale SGTL5000 (I2S),
 TI TLV320AIC23B (I2S)
 Realtek ALC892-CG (HDA)

Connector
 5x 3.5 mm jack Surround audio
 S/PDIF

Speaker
 2W amplified speaker connectors

Touch

Controller
 Jumper selectable:
 TSC2046 (4 wire by SPI)
 TSC2004 (4 wire by I2C)
 ADS7845 (5 wire by SPI)

Connector
 USB 4/5 wire touch controller
 4 wire touchpanel (USB/I2C/SPI)
 5 wire touchpanel (USB/SPI)

Power Specifications

Input Power
 Battery
 10~30 VDC
 Smart battery connector

Block Diagram

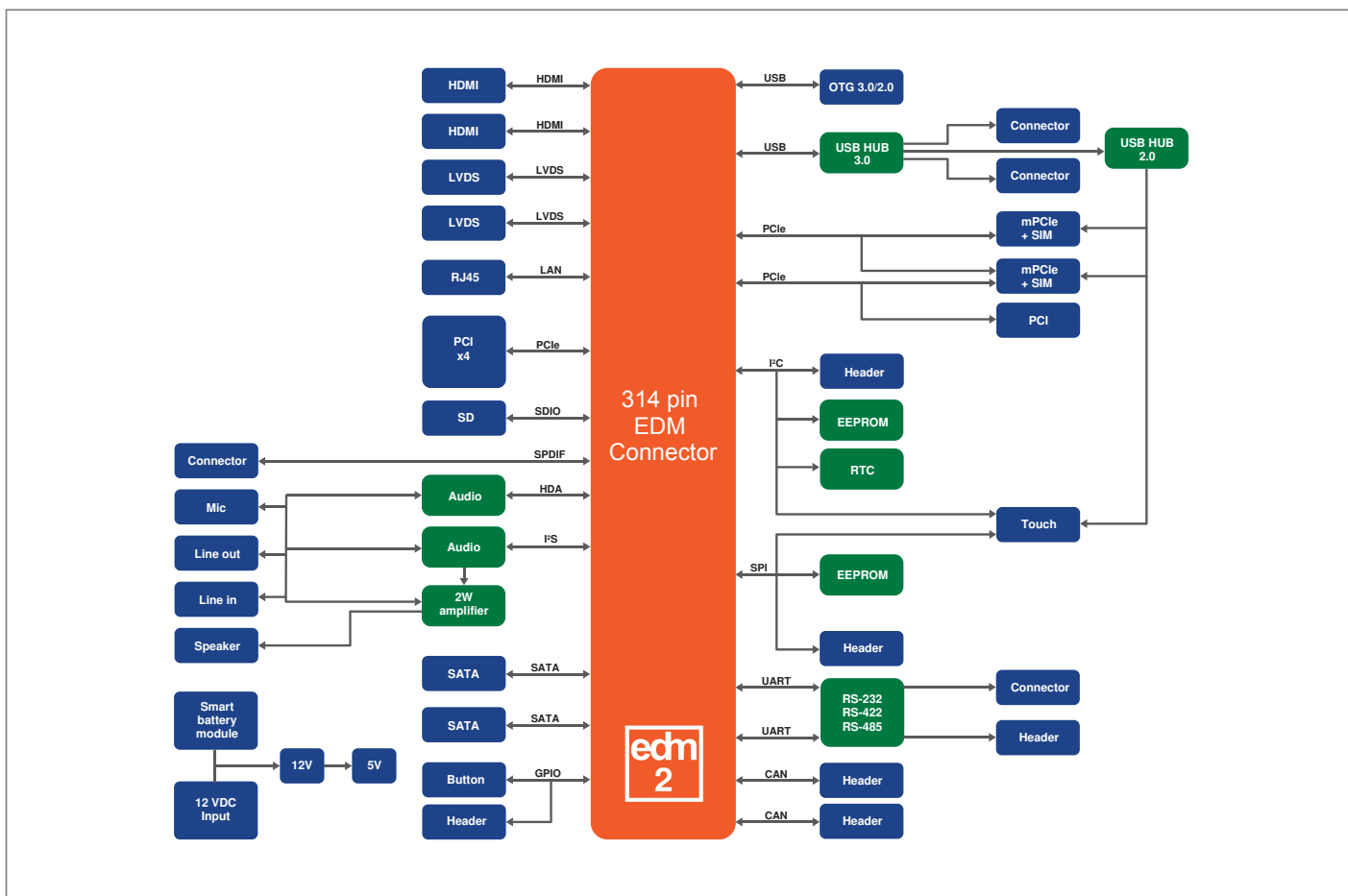

Environmental and Mechanical

Temperature	Commercial : 0° to 60° C
Humidity	10 to 90%
Module Connector	314 pins MXM3
Form Factor	MicroATX Form Factor
Dimensions	244 x 244 mm 9 ⁵ / ₈ x 9 ⁵ / ₈ inch
MTBF	>100,000 hours
Weight	380 grams
Shock	50G / 25ms
Vibration	20G / 0-600 Hz

Ordering Information

EDM2-WIZARD

MicroATX Form Factor Wizard Carrier Board for EDM Type 2 System on Modules

EDM2-WIZARD-START

MicroATX Form Factor Wizard Carrier Board for EDM Type 2 System on Modules including cablekit and adaptor

* Feel free to contact us for custom tailored Carrier Board request for your projects.

Dimensions

(units in mm)

