



Chipsmall Limited consists of a professional team with an average of over 10 year of expertise in the distribution of electronic components. Based in Hongkong, we have already established firm and mutual-benefit business relationships with customers from,Europe,America and south Asia,supplying obsolete and hard-to-find components to meet their specific needs.

With the principle of "Quality Parts,Customers Priority,Honest Operation,and Considerate Service",our business mainly focus on the distribution of electronic components. Line cards we deal with include Microchip,ALPS,ROHM,Xilinx,Pulse,ON,Everlight and Freescale. Main products comprise IC,Modules,Potentiometer,IC Socket,Relay,Connector.Our parts cover such applications as commercial,industrial, and automotives areas.

We are looking forward to setting up business relationship with you and hope to provide you with the best service and solution. Let us make a better world for our industry!



Contact us

Tel: +86-755-8981 8866 Fax: +86-755-8427 6832

Email & Skype: info@chipsmall.com Web: www.chipsmall.com

Address: A1208, Overseas Decoration Building, #122 Zhenhua RD., Futian, Shenzhen, China



THIS COPY IS PROVIDED ON A RESTRICTED BASIS AND IS NOT TO BE USED IN ANY WAY DETRIMENTAL TO THE INTERESTS OF PANDUIT CORP.

PANDUIT PART #	WIRE RANGE AWG [mm ²]	TAB SIZE INCH [mm]	HOUSING COLOR	MAX WIRE INSULATION DIA.	DIMENSIONS in. [mm]		
					L± .03 [0,8]	W± .01 [0,3]	H± .01 [0,3]
EDV18-250B	#22-18 [0,5-1,0]	.250 X .032 [6,3 X 0,8]	RED	.150 [3,8]	.81 [20,6]	.29 [7,4]	.12 [3,0]
EDV14-250B*	#16-14 [1,5-2,5]	.250 X .032 [6,3 X 0,8]	BLUE	.170 [4,3]	.81 [20,6]	.29 [7,4]	.12 [3,0]

*UL RECOGNIZED ONLY

NOTES:

- UL LISTED AND CSA CERTIFIED FOR:
 - STRANDED COPPER WIRE ONLY
 - 221°F (105°C) MAX TEMP RATING
 - 600V MAX VOLTAGE
- MATERIAL:
 - STAMPING: .016" (0.41) THK BRASS, TIN PLATED
 - HOUSING: VINYL
- INSTALLATION TOOLS:
 - UL LISTED AND CSA CERTIFIED: CT-520, CT-1525
 - UL RECOGNIZED: CT-520, CT-1525
- WIRE STRIP LENGTH 1/4" ^{+1/32} ₋₀ [6.3mm ^{+0.8} ₋₀]
- FIRST INSERTION FORCE: 12 LB (53N) MAX
 FIRST WITHDRAWAL FORCE: 12 LB (53N) MAX
 6 LB (27N) MIN
- SEE WWW.PANDUIT.COM FOR PACKAGE QUANTITIES INDICATED BY PART NUMBER SUFFIX
- DIMENSIONS IN BRACKETS ARE METRIC EQUIVALENT

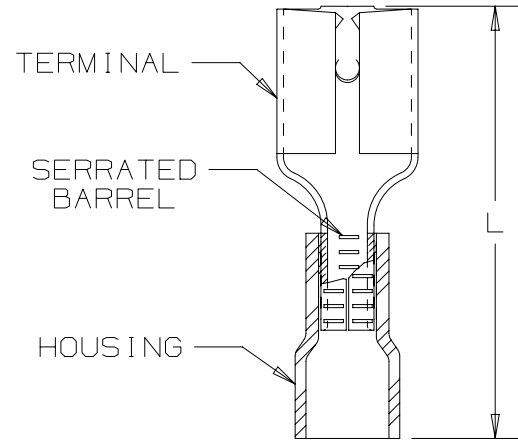
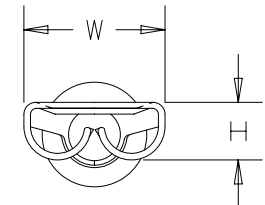

MAX. WIRE INSUL. DIA.

TITLE STRONGHOLD FEMALE DISCONNECT (250 SERIES) VINYL INSULATED, BUTTED SEAM #22-14 AWG CUSTOMER DRAWING	
ITEM REVISION NAME	00123SHJ/00
DATASET FILE NAME	00123SHJ/00
UNLESS OTHERWISE SPECIFIED, DIMENSIONAL TOLERANCES ARE: IN [mm] .x ± .1 [2.54] .xxx ± .005 [.127] .xx ± .01 [.25] ANGLES ± 5 °	
THIRD ANGLE PROJECTION	
MATERIAL: SEE NOTES	
DRAWING NUMBER: SH41307	
DRAWN BY	JHNU
DATE	2/18
CHK	TMR
SCALE	NTS
SHT 1 OF 1	
SIZE	A

REV	DATE	BY	CHK	APR	DESCRIPTION	ECN
00	2/18	JHNU	TMR	RGB	RELEASED	00123SH

D10100DA/20