



Chipsmall Limited consists of a professional team with an average of over 10 year of expertise in the distribution of electronic components. Based in Hongkong, we have already established firm and mutual-benefit business relationships with customers from,Europe,America and south Asia,supplying obsolete and hard-to-find components to meet their specific needs.

With the principle of "Quality Parts,Customers Priority,Honest Operation,and Considerate Service",our business mainly focus on the distribution of electronic components. Line cards we deal with include Microchip,ALPS,ROHM,Xilinx,Pulse,ON,Everlight and Freescale. Main products comprise IC,Modules,Potentiometer,IC Socket,Relay,Connector.Our parts cover such applications as commercial,industrial, and automotives areas.

We are looking forward to setting up business relationship with you and hope to provide you with the best service and solution. Let us make a better world for our industry!



## Contact us

Tel: +86-755-8981 8866 Fax: +86-755-8427 6832

Email & Skype: info@chipsmall.com Web: www.chipsmall.com

Address: A1208, Overseas Decoration Building, #122 Zhenhua RD., Futian, Shenzhen, China



DELTA ELECTRONICS, INC.  
 252, SHANG YING ROAD, KUEI SAN  
 TAoyUAN SHIEN 333, TAIWAN, R. O. C.

TEL : 886-(0)3-3591968  
 FAX : 886-(0)3-3591991

SPECIFICATION FOR APPROVAL  
 \*\*\*\*\*

Customer:

|                    |               |           |
|--------------------|---------------|-----------|
| Description:       | DC FAN        |           |
| Customer P/N:      |               | REV:      |
| Delta Model NO.:   | EFB0412MD-R00 |           |
| Sample Rev:        | 00            | Issue NO: |
| Sample Issue Date: | MAY.11.2005.  | Quantity: |

1. SCOPE:

THIS SPECIFICATION DEFINES THE ELECTRICAL AND MECHANICAL CHARACTERISTICS OF THE DC BRUSHLESS AXIAL FLOW FAN. THE FAN MOTOR IS WITH TWO PHASES AND FOUR POLES.

2. CHARACTERS:

| ITEM  | DESCRIPTION  |
|---|--|
| RATED VOLTAGE                                   | 12 VDC   |
| OPERATION VOLTAGE                               | 7.0 - 13.8 VDC   |
| START VOLTAGE (ENVIRONMENT TEMPERATURE AT 25°C) | ≤ 5.0 VDC  |
| INPUT CURRENT                                   | 0.06 (MAX. 0.10) A   |
| INPUT POWER                                     | 0.72 (MAX. 1.20) W   |
| SPEED   | 6300 R.P.M. (REF.)   |
| MAX. AIR FLOW (AT ZERO STATIC PRESSURE)         | 0.203 (MIN. 0.176 ) M <sup>3</sup> /MIN.<br>7.17 (MIN. 6.22 ) CFM                |
| MAX.AIR PRESSURE (AT ZERO AIR FLOW)             | 5.54 (MIN. 4.18 ) mmH <sub>2</sub> O<br>0.218 (MIN. 0.165 ) inchH <sub>2</sub> O |
| ACOUSTICAL NOISE (AVG.)                         | 24.0 (MAX. 27.0) dB-A  |
| INSULATION TYPE                                 | UL: CLASS A  |

(continued)

PART NO:

DELTA MODEL: EFB0412MD-R00

|                        |  |
|------------------------|--|
| INSULATION STRENGTH    | 10 MEG OHM MIN. AT 500 VDC<br>(BETWEEN FRAME AND (+) TERMINAL)                                       |
| DIELECTRIC STRENGTH    | 5 mA MAX. AT 500 VAC 60 Hz<br>ONE MINUTE, (BETWEEN FRAME AND<br>(+) TERMINAL)                        |
| EXTERNAL COVER         | OPEN TYPE  |
| LIFE EXPECTANCE        | 70,000 HOURS CONTINUOUS OPERATION<br>AT 40 °C WITH 15 ~ 65 %RH.                                      |
| ROTATION               | CLOCKWISE VIEW<br>FROM NAME PLATE SIDE   |
| OVER CURRENT SHUT DOWN | THE CURRENT WILL SHUT DOWN,<br>WHEN LOCKING ROTOR.   |
| LEAD WIRE              | UL 1061 -F- AWG #24<br>BLACK WIRE NEGATIVE(-)<br>RED WIRE POSITIVE(+)<br>BLUE WIRE LOCK SIGNAL(-R00) |

- NOTES: 1. ALL READINGS ARE MEASURED AFTER STABLY WARMING UP THROUGH 10 MINUTES  
2. THE VALUES WRITTEN IN PARENS , ( ), ARE LIMITED SPEC.  
3. ACOUSTICAL NOISE MEASURING CONDITION:

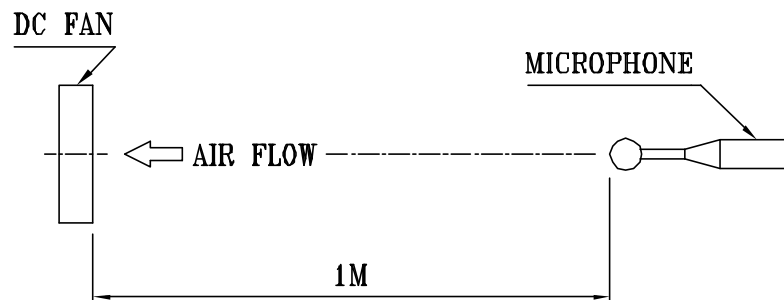

NOISE IS MEASURED AT RATED VOLTAGE IN FREE AIR IN ANECHOIC CHAMBER WITH B & K SOUND LEVEL METER WITH MICROPHONE AT A DISTANCE OF ONE METER FROM THE FAN INTAKE.

-----  
PART NO:  
-----

DELTA MODEL:       EFB0412MD-R00  
-----

3. MECHANICAL:

- 3-1. DIMENSIONS ----- SEE DIMENSIONS DRAWING
- 3-2. FRAME ----- PLASTIC UL: 94V-0
- 3-3. IMPELLER ----- PLASTIC UL: 94V-0
- 3-4. BEARING SYSTEM ----- TWO BALL BEARINGS
- 3-5. WEIGHT ----- 33 GRAMS

4. ENVIRONMENTAL:

- 4-1. OPERATING TEMPERATURE ----- -10 TO +70 DEGREE C
- 4-2. STORAGE TEMPERATURE ----- -40 TO +75 DEGREE C
- 4-3. OPERATING HUMIDITY ----- 5 TO 90 % RH
- 4-4. STORAGE HUMIDITY ----- 5 TO 95 % RH

5. PROTECTION:

5-1. LOCKED ROTOR PROTECTION

IMPEDANCE OF MOTOR WINDING PROTECTS MOTOR FROM FIRE IN 96 HOURS OF LOCKED ROTOR CONDITION AT THE RATED VOLTAGE.

5-2. POLARITY PROTECTION

BE CAPABLE OF WITHSTANDING IF REVERSE CONNECTION FOR POSITIVE AND NEGATIVE LEADS.

6. RE OZONE DEPLETING SUBSTANCES:

- 6-1. NO CONTAINING PBBs, PBBOs, CFCs, PBBEs, PBDPEs AND HCFCs.

7. PRODUCTION LOCATION

- 7-1. PRODUCTS WILL BE PRODUCED IN CHINA OR THAILAND OR TAIWAN.

-----  
PART NO:  
-----

DELTA MODEL:        EFB0412MD-R00  
-----

8. BASIC RELIABILITY REQUIREMENT:

8-1. THERMAL        LOW TEMPERATURE: -40°C  
CYCLING            HIGH TEMPERATURE: +80°C  
                      SOAK TIME: 30 MINUTES  
                      TRANSITION TIME < 5 MINUTES  
                      DUTY CYCLES: 5

8-2. HUMIDITY        TEMPERATURE: +25°C ~ +65°C  
EXPOSURE            HUMIDITY: 90-98% RH @ +65°C  
                              FOR 4 HOURS/CYCLE  
                      POWER: NON-OPERATING  
                      TEST TIME: 168 HOURS

8-3. VIBRATION      TEMPERATURE: +25°C  
                      ORIENTATION: X, Y, Z  
                      POWER: NON-OPERATING  
                      VIBRATION LEVEL: OVERALL  $g_{RMS}=3.2$

| FREQUENCY(Hz) | PSD( $G^2/Hz$ ) |
|---------------|-----------------|
| 10            | 0.040           |
| 20            | 0.100           |
| 40            | 0.100           |
| 800           | 0.002           |
| 1000          | 0.002           |

TEST TIME: 2 HOURS ON EACH ORIENTATION

8-4. MECHANICAL    TEMPERATURE: +20°C  
SHOCK                ORIENTATION: X, Y, Z  
                      POWER: NON-OPERATING  
                      ACCELERATION: 20 G MIN.  
                      PULSE: 11 ms HALF-SINE WAVE  
                      NUMBER OF SHOCKS: 5 SHOCKS  
                                      FOR EACH DIRECTION

8-5. LIFE            TEMPERATURE: MAX , OPERATING TEMPERATURE  
                      POWER: OPERATING  
                      DURATION: 1000 HOURS MIN.

PART NO:

DELTA MODEL: EFB0412MD-R00

P & Q CURVE:

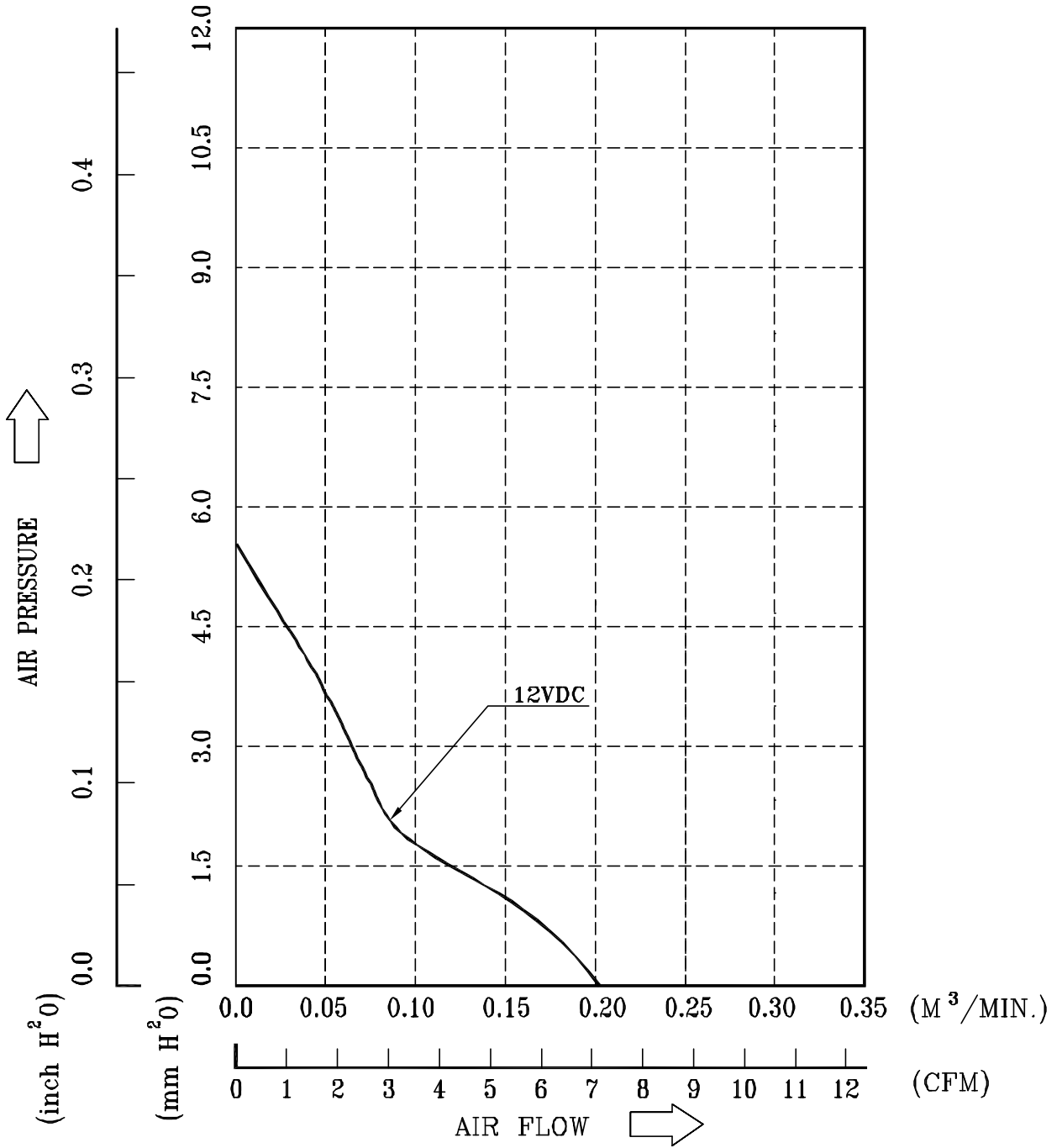

\* TEST CONDITION: INPUT VOLTAGE ----- OPERATION VOLTAGE  
TEMPERATURE ----- ROOM TEMPERATURE  
HUMIDITY ----- 65%RH

-----  
PART NO:  
-----

DELTA MODEL:       EFB0412MD-R00  
-----

Attach: DIMENSIONS DRAWING

LABEL:

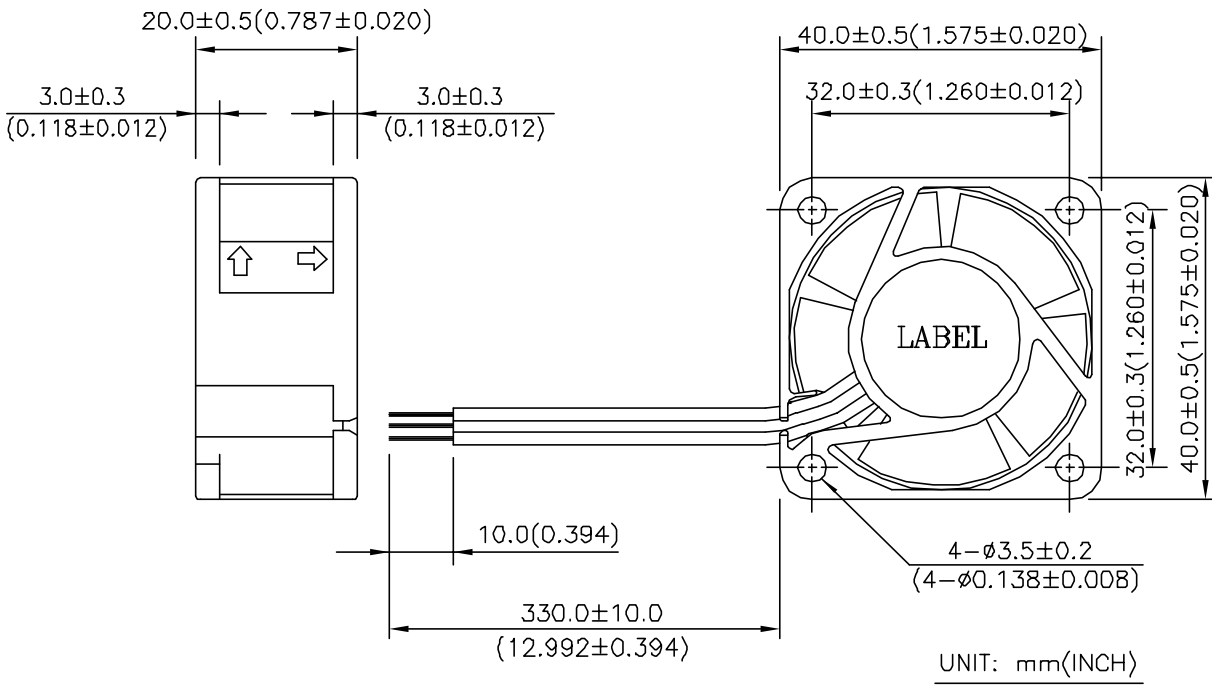

-----  
PART NO:  
-----

DELTA MODEL:        EFB0412MD-R00  
-----

### 11. ROTATION DETECT (RD) SIGNAL:

#### 1. OUTPUT CIRCUIT - OPEN COLLECTOR MODE:

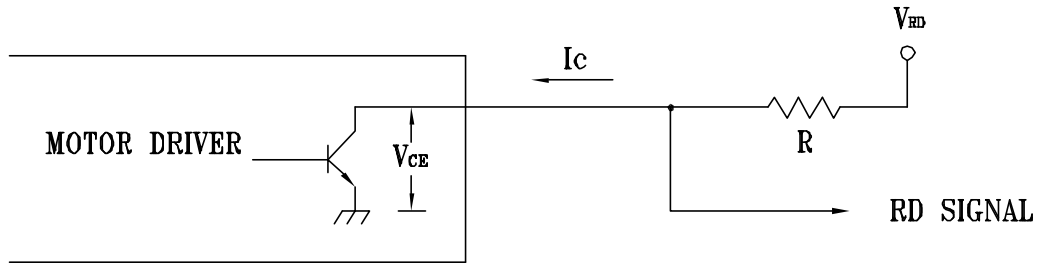

#### CAUTION:

THE LEAD WIRE OF RD SIGNAL CAN NOT TOUCH  
THE LEAD WIRE OF POSITIVE OR NEGATIVE.

#### 2. SPECIFICATION:

$V_{CE(sat)} = 0.5V$  MAX.         $V_{RD} = 15V$  MAX.

$I_c = 5mA$  MAX.         $R \geq V_{RD}/I_c$

#### 3. ROTATION DETECT WAVEFORM:

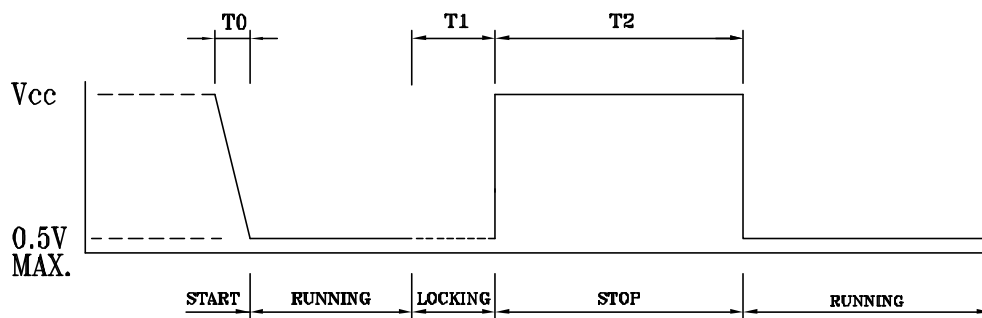

$T_0 = 48ns$  TYP.

$T_1 = 670 \pm 160ns$

$T_2 = 980 \pm 300ms$





## **Descriptions:**

- 1. Delta will not guarantee the performance of the products if the application condition falls outside the parameters set forth in the specification.**
- 2. A written request should be submitted to Delta prior to approval if deviation from this specification is required.**
- 3. Please exercise caution when handling fans. Damage may be caused when pressure is applied to the impeller, if the fans are handled by the lead wires, or if the fans are hard-dropped to the production floor.**
- 4. Except as pertains to some special designs, there is no guarantee that the products will be free from any such safety problems or failures as caused by the introduction of powder, droplets of water or encroachment of insect into the hub.**
- 5. The above-mentioned conditions are representative of some unique examples and viewed as the first point of reference prior to all other information.**
- 6. It is very important to establish the correct polarity before connecting the fan to the power source. Positive (+) and Negative (-). Damage may be caused to the fans if connection is with reverse polarity, as there is no foolproof method to protect against such error.**
- 7. Delta fans are not suitable where any corrosive fluids are introduced to their environment.**
- 8. Please ensure all fans are stored according to the storage temperature limits specified. Do not store fans in a high humidity environment. We highly recommend performance testing is conducted before shipping, if the fans have been stored over 6 months.**
- 9. Not all fans are provided with the Lock Rotor Protection feature. If you impair the rotation of the impeller for the fans that do not have this function, the performance of those fans will lead to failure.**
- 10. Please be cautious when mounting the fan. Incorrect mounting of fans may cause excess resonance, vibration and subsequent noise.**
- 11. It is important to consider safety when testing the fans. A suitable fan guard should be fitted to the fan to guard against any potential for personal injury.**
- 12. Except where specifically stated, all tests are carried out at relative (ambient) temperature and humidity conditions of 25°C, 65%. The test value is only for fan performance itself.**
- 13. Be certain to connect an “over 4.7µF” capacitor to the fan externally when the application calls for using multiple fans in parallel, to avoid any unstable power.**

Model AFC followed by 0512 , 0612, 0712, 0812, 0824, 0912 or 0924, followed by "A", "AB" , "AD", "B", "BB" , "BD" or "C"; Model AFC followed by 0912, followed by "A" or "B", followed by -(H), -(HH), -(M); Model ASC followed by 0612, 0812, 0912 followed by "A" or "B".

Model ASB followed by 0605, followed by H, L, M; Model ASB followed by 0612, followed by H-SB, L-SB or M-SB; Model ASB followed by 0812 or 0824, followed by H, HH, L, LL or M; Model ASB followed by 0912, 0924, followed by H, HH, L, L-V, M; Model ASB followed by 0924 followed by H, HH, L or M, Model ASB0812L-SB, H-SB or M-SB; Model ASB0912L-SB, H-SB or M-SB; Model DSB followed by 0612, 0812, followed by H, H-N, L, L-N, M, M-N.

Model AFB followed by 0612, followed by H, HH, L, M, followed by SB; Model AFB followed by 0812, followed by H, L or M, followed by SB; Model AFB followed by 0912, followed by H, L or M, followed by SB.

Model AFB followed by 1212, followed by HE, HHE, LE, ME, SHE VHE; Model AFB followed by 1224, followed by HE, HHE, LE, ME, SHE, VHE; Model AFB followed by 1248, followed by HE, HHE, LE, ME, VHE; Model EFB followed by 1212, followed by HE, HHE, LE, ME, SHE, VHE; Model EFB followed by 1224, followed by HE, HHE, LE, ME, SHE, VHE; Model EFB followed by 1248, followed by HE, HHE, LE, ME, SHE, VHE.

Model BFB followed by 1012, followed by H, HH, L, LL or M; Model BFB followed by 1024, followed by H, HH, L, LL or M; Model BFB followed by 1212, followed by H, HH, L, LL, M or VH; Model BFB followed by 1224, followed by H, HH, L, LL or M; Model BFB followed by 1248, followed by H, HH, L, LL or M.

Model BFB followed by 1212, 1224, followed by HE, HHE, LE, ME or VH; Model BFB followed by 1248, followed by HE, LE or ME; Model BFB followed by 1612, followed by H, L or M; Model BFB followed by 1624, followed by H, L or M; Model BFB followed by 1648, followed by H, L or M.

Models BFB0405HE, -LE, -ME, BFB0412HE, -HHE, -LE, -ME.

Models AUB0812H, -HH, -L, -LB, -M, -SHB, -VH, AUB0824H, -HH, -L, -LB, -M, -SHB, -VH.

Model BFB followed by 0505, 0512, 0524, followed by H, HH, L or M; Model BSB followed by 0505, 0512, 0524, followed by H, HH, L or M.

Models EFB1212 -H, -HF, -HH, -HHF, -L, -LF, -M, -MF, -SH, -VH, -VHF, EFB1224 -H, -HF, -HH, -HHF, -L, -LF, -M, -MF, -SH, -VH, -VHF, EFB1248-H, -HH, -L, -M, -SH, -VH.

Model EFB followed by 0405, followed by HD, HHD, LD, LLD, MD VHD; Model EFB followed by 0412, followed by HD, HHD, LD, LLD, MD, VHD; Model EFB followed by 0424, followed by HD, HHD, LD, LLD, MD, VHD.

Models BFB0305HA, -HHA, -LA, -MA, BFB0312HA, -HHA, -LA, -MA.

Models AFB1512H, -L, -M, AFB1548H, -L, -M, AFB1712H, -L, -M, AFB1748H, -L, -M, EFB1248HF, -HHF, -LF, -MF, -VHF, EFB1548HG, -HHG, -LG, -MG, -VHG, EFB1748HG, -HHG, -



|            |    |     |             |
|------------|----|-----|-------------|
| DSB0812L   | 12 | 110 | R00 RR0 F00 |
| DSB0812M   | 12 | 140 | R00 RR0 F00 |
| DSB0812L-N | 12 | 110 |             |
| DSB0812M-N | 12 | 140 |             |
| DSB0812H-N | 12 | 210 |             |
| Efb SERIES |    |     | -           |
| Efb0405HD  | 5  | 380 | F00 R00 STD |
| Efb0405HHD | 5  | 450 | F00 R00 STD |
| Efb0405LD  | 5  | 160 | F00 R00 STD |
| Efb0405LLD | 5  | 100 | F00 R00 STD |
| Efb0405MD  | 5  | 240 | F00 R00 STD |
| Efb0405VHD | 5  | 500 | F00 R00 STD |
| Efb0412HD  | 12 | 120 | F00 R00 STD |
| Efb0412HHD | 12 | 150 | F00 R00 STD |
| Efb0412LD  | 12 | 80  | F00 R00 STD |
| Efb0412LLD | 12 | 60  | F00 R00 STD |
| Efb0412MD  | 12 | 100 | F00 R00 STD |
| Efb0412VHD | 12 | 180 | F00 R00 STD |
| Efb0424HD  | 24 | 100 | F00 R00 STD |
| Efb0424HHD | 24 | 120 | F00 R00 STD |
| Efb0424LD  | 24 | 60  | F00 R00 STD |
| Efb0424LLD | 24 | 50  | F00 R00 STD |
| Efb0424MD  | 24 | 80  | F00 R00 STD |
| Efb0424VHD | 24 | 140 | F00 R00 STD |
| Efb0512LA  | 12 | 80  | -           |
| Efb0512MA  | 12 | 120 | -           |
| Efb0512HA  | 12 | 150 | -           |

# VDE Prüf- und Zertifizierungsinstitut

## Gutachten mit Fertigungsüberwachung

Ausweis-Nr. /  
Licence No. 001764 ÜG

Blatt /  
page 8

Name und Sitz des Genehmigungs-Inhabers / Name and registered seat of the Licence holder

Delta Electronics Inc.  
186 Ruey Kuang Road  
NEIHU TAIPEI (114), Taiwan

Aktenzeichen / File ref.

11641-2611-0001 / 32Y3F F13 / SFK

letzte Änderung / updated

2001-06-05

Datum / Date

1994-06-08

Dieses Blatt gilt nur in Verbindung mit Blatt 1 des Gutachtens mit Fertigungsüberwachung Nr. 001764 ÜG.  
*This supplement is only valid in conjunction with page 1 of the Licence No. 001764 ÜG.*

Jahresgebühren-Einheiten /  
Annual fee units

|                                       |         |      |
|---------------------------------------|---------|------|
| AFC0824C                              | DC 24 V | 1,00 |
| AFC0912C                              | DC 12 V | 1,00 |
| AFC0924C                              | DC 24 V | 1,00 |
| AFC0612AD                             | DC 12 V | 1,00 |
| AFC0612BD                             | DC 12 V | 1,00 |
| EFB1212LF/MF/HF/HHF/VHF (R00,F00,STD) | DC 12 V | 5,00 |
| EFB1224LF/MF/HF/HHF/VHF (R00,F00,STD) | DC 24 V | 5,00 |
| AFB0524LB/MB/HB/HHB (R00,F00,STD)     | DC 24 V | 4,00 |
| BFB0524LM/H/HH (R00,F00,STD)          | DC 24 V | 4,00 |
| BSB0505LM (R00,F00,STD)               | DC 5 V  | 2,00 |
| BSB0512LM/H/HH (R00,F00,STD)          | DC 12 V | 4,00 |
| BSB0524LM/H/HH (R00,F00,STD)          | DC 24 V | 4,00 |
| AUB0612LM/H/HH                        | DC 12 V | 4,00 |
| AUB0624LM/H/HH                        | DC 24 V | 4,00 |
| AUB0912LM/H/HH/VH                     | DC 12 V | 5,00 |
| AUB0924LM/H/HH/VH                     | DC 24 V | 5,00 |
| EFB0405LLD/LD/MD/HD/HHD/VHD           | DC 5 V  | 6,00 |
| EFB0412LLD/LD/MD/HD/HHD/VHD           | DC 12 V | 6,00 |
| EFB0424LLD/LD/MD/HD/HHD/VHD           | DC 24 V | 6,00 |
| AFB0605HH                             | DC 5 V  | 2,00 |
| EFB1248LF/MF/HF/HHF/VHF               | DC 48 V | 5,00 |
| DSB0812L-N/M-N/H-N                    | DC 12 V | 3,00 |
| BFB0305LA/MA/HA/HHA                   | DC 5 V  | 4,00 |
| BFB0312LA/MA/HA/HHA                   | DC 12 V | 4,00 |
| AFB0305LK/MK/HK                       | DC 5 V  | 3,00 |
| AFB0405LK/MK/HK                       | DC 5 V  | 3,00 |
| BFB03505LA/MA/HA/HHA                  | DC 5 V  | 4,00 |
| BFB03512LA/MA/HA/HHA                  | DC 12 V | 4,00 |
| SFB0112M/H/HH/VH                      | DC 12 V | 4,00 |
| SUB0112M/H/HH/VH                      | DC 12 V | 4,00 |
| EFB1212LM/H/HH/VH/SH                  | DC 12 V | 6,00 |
| EFB1224LM/H/HH/VH/SH                  | DC 24 V | 6,00 |
| EFB0912LM/H/HH/VH/SH                  | DC 12 V | 6,00 |
| EFB0924LM/H/HH/VH/SH                  | DC 24 V | 6,00 |
| AFB02505LB/MB/HB/HHB                  | DC 5 V  | 4,00 |
| FFB1212HE/HHE/VHE/SHE                 | DC 12 V | 4,00 |
| FFB1224HE/HHE/VHE/SHE/EHE             | DC 24 V | 5,00 |
| EFB1712LG/MG/HG/HHG                   | DC 12 V | 4,00 |
| EFB1724LG/MG/HG/HHG/HG/SHG            | DC 24 V | 6,00 |
| EFB1512LG/MG/HG/HHG                   | DC 12 V | 4,00 |

Fortsetzung siehe Blatt 9 /