



Chipsmall Limited consists of a professional team with an average of over 10 year of expertise in the distribution of electronic components. Based in Hongkong, we have already established firm and mutual-benefit business relationships with customers from,Europe,America and south Asia,supplying obsolete and hard-to-find components to meet their specific needs.

With the principle of "Quality Parts,Customers Priority,Honest Operation,and Considerate Service",our business mainly focus on the distribution of electronic components. Line cards we deal with include Microchip,ALPS,ROHM,Xilinx,Pulse,ON,Everlight and Freescale. Main products comprise IC,Modules,Potentiometer,IC Socket,Relay,Connector.Our parts cover such applications as commercial,industrial, and automotives areas.

We are looking forward to setting up business relationship with you and hope to provide you with the best service and solution. Let us make a better world for our industry!



Contact us

Tel: +86-755-8981 8866 Fax: +86-755-8427 6832

Email & Skype: info@chipsmall.com Web: www.chipsmall.com

Address: A1208, Overseas Decoration Building, #122 Zhenhua RD., Futian, Shenzhen, China





EFC4619R

Power MOSFET 24V, 6A, 23mΩ N-Channel Dual EFCP

ON Semiconductor®

<http://onsemi.com>

Features

- 2.5V drive
- Common-drain type
- 2KV ESD HBM
- Protection diode in
- Halogen free compliance

Applications

- Lithium-ion battery charging and discharging switch

Specifications

Absolute Maximum Ratings at $T_a = 25^\circ\text{C}$

Parameter	Symbol	Conditions	Ratings	Unit
Source to Source Voltage	V_{SSS}		24	V
Gate to Source Voltage	V_{GSS}		± 12	V
Source Current (DC)	I_S		6	A
Source Current (Pulse)	I_{SP}	$PW \leq 10\mu\text{s}$, duty cycle $\leq 1\%$	60	A
Total Dissipation	P_T	When mounted on ceramic substrate (5000mm ² ×0.8mm)	1.6	W
Channel Temperature	T_{ch}		150	°C
Storage Temperature	T_{stg}		-55 to +150	°C

Stresses exceeding Maximum Ratings may damage the device. Maximum Ratings are stress ratings only. Functional operation above the Recommended Operating Conditions is not implied. Extended exposure to stresses above the Recommended Operating Conditions may affect device reliability.

Package Dimensions

unit : mm (typ)
7074

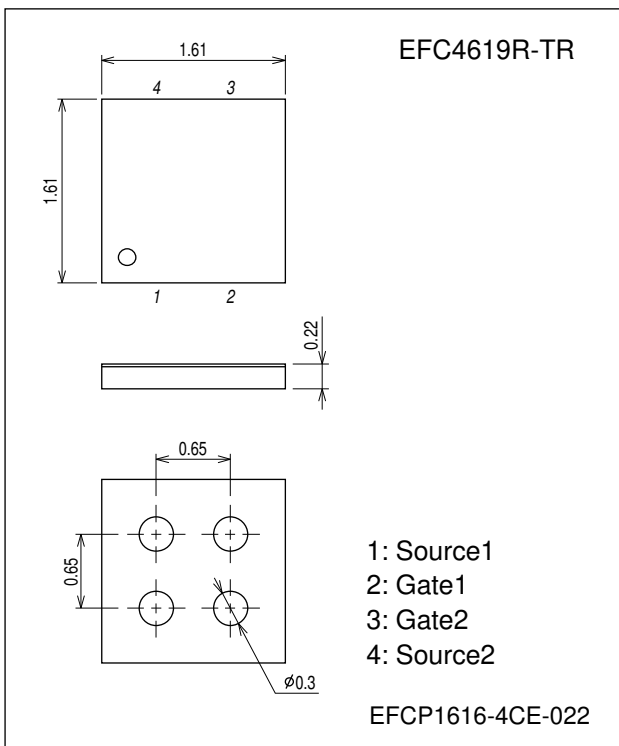

Ordering & Package Information

Device	Package	Shipping	note
EFC4619R-TR	EFCP	5000 pcs. / reel	Pb-Free and Halogen-Free

Packing Type: TR

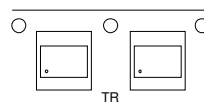

Marking

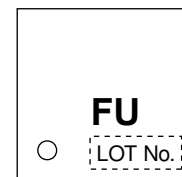

Electrical Connection

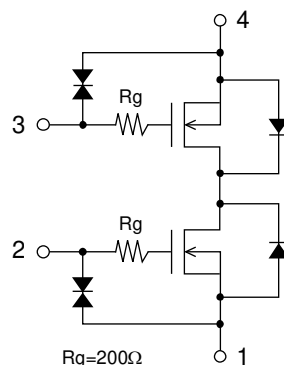

EFC4619R

Electrical Characteristics at Ta = 25°C

Parameter	Symbol	Conditions	Ratings			Unit
			min	typ	max	
Source to Source Breakdown Voltage	V(BR) _{SSS}	I _S =1mA, V _{GS} =0V Test Circuit 1	24			V
Zero-Gate Voltage Source Current	I _{SSS}	V _{SS} =20V, V _{GS} =0V Test Circuit 1			1	μA
Gate to Source Leakage Current	I _{GSS}	V _{GS} =±8V, V _{SS} =0V Test Circuit 2			±1	μA
Cutoff Voltage	V _{GS(off)}	V _{SS} =10V, I _S =1mA Test Circuit 3	0.5		1.3	V
Forward Transfer Admittance	y _{fs}	V _{SS} =10V, I _S =3A Test Circuit 4		5.8		S
Static Source to Source On-State Resistance	R _{SS(on)1}	I _S =3A, V _{GS} =4.5V Test Circuit 5	13.5	19.8	23	mΩ
	R _{SS(on)2}	I _S =3A, V _{GS} =4.0V Test Circuit 5	14	20.5	24	mΩ
	R _{SS(on)3}	I _S =3A, V _{GS} =3.7V Test Circuit 5	14.5	21	25.5	mΩ
	R _{SS(on)4}	I _S =3A, V _{GS} =3.1V Test Circuit 5	14.9	23	30	mΩ
	R _{SS(on)5}	I _S =3A, V _{GS} =2.5V Test Circuit 5	18.5	27	35	mΩ
Turn-ON Delay Time	t _{d(on)}	V _{SS} =10V, V _{GS} =4.5V, I _S =3A Test Circuit 7		340		ns
Rise Time	t _r			440		ns
Turn-OFF Delay Time	t _{d(off)}			24400		ns
Fall Time	t _f			22400		ns
Total Gate Charge	Q _g		V _{SS} =10V, V _{GS} =4.5V, I _S =6A Test Circuit 8		21.7	
Forward Source to Source Voltage	V _{F(S-S)}	I _S =3A, V _{GS} =0V Test Circuit 6		0.8	1.2	V

Test circuits are example of measuring FET1 side

Test Circuit 1
I_{SSS}

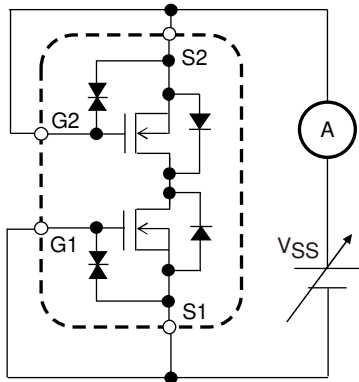

Test Circuit 2
I_{GSS}

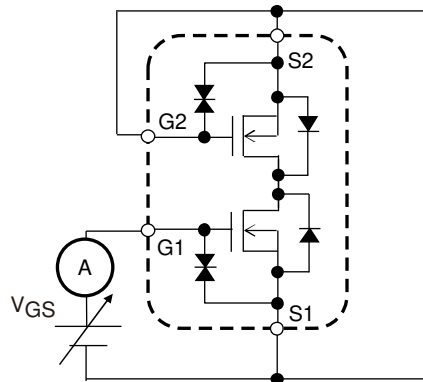

When FET1 is measured, Gate and Source of FET2 are short-circuited.

Test Circuit 3
V_{GS(off)}

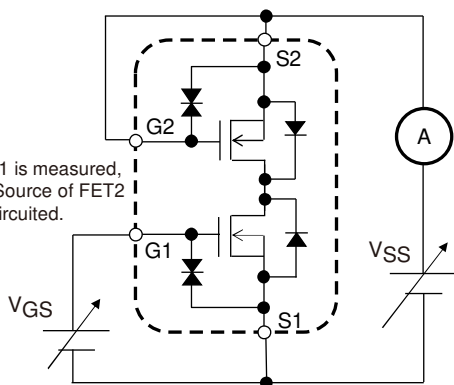

When FET1 is measured, Gate and Source of FET2 are short-circuited.

Test Circuit 4
|y_{fs}|

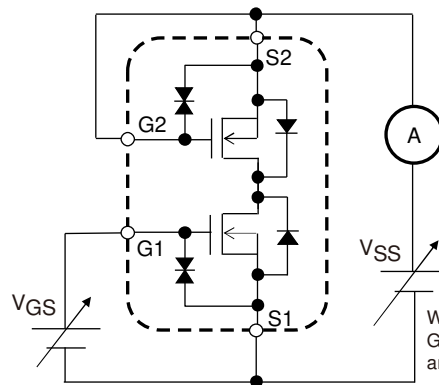

When FET1 is measured, Gate and Source of FET2 are short-circuited.

Test Circuit 5
R_{SS(on)}

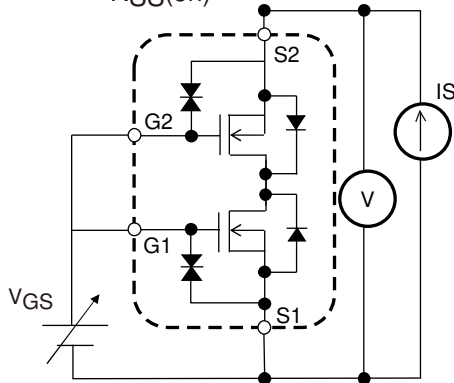

Test Circuit 6
V_{F(S-S)}

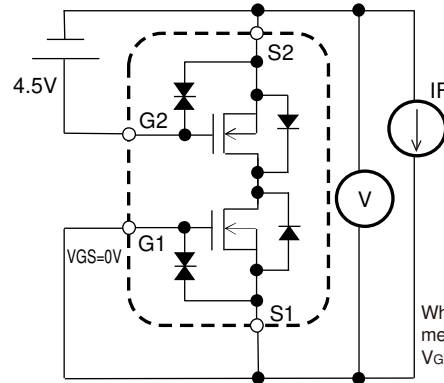

When FET1 is measured, +4.5V is added to V_{GS} of FET2.

Test Circuit 7
t_{d(on)}, t_r, t_{d(off)}, t_f

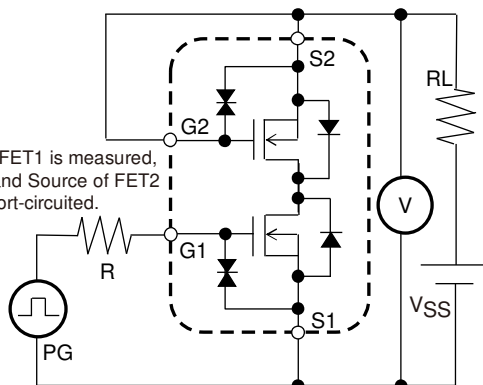

When FET1 is measured, Gate and Source of FET2 are short-circuited.

Test Circuit 8
Q_g

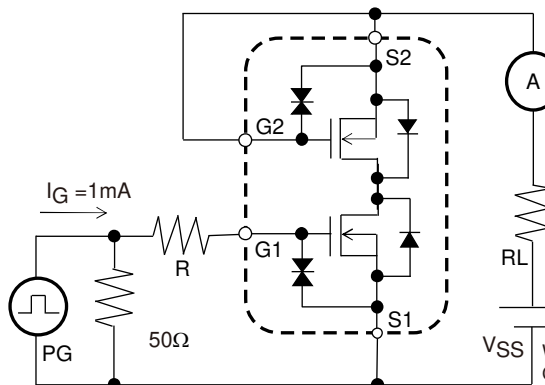

When FET1 is measured, Gate and Source of FET2 are short-circuited.

EFC4619R

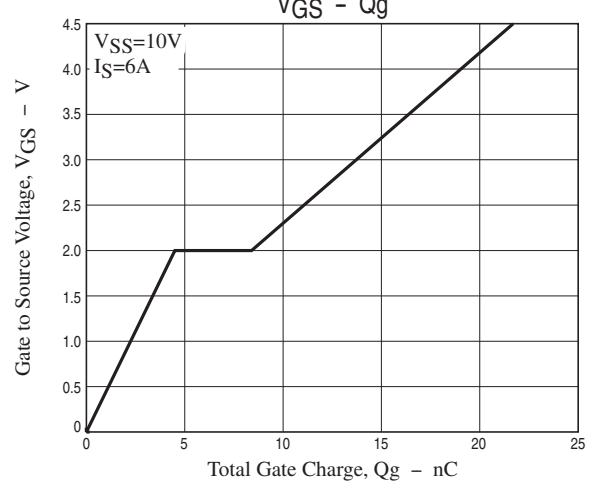
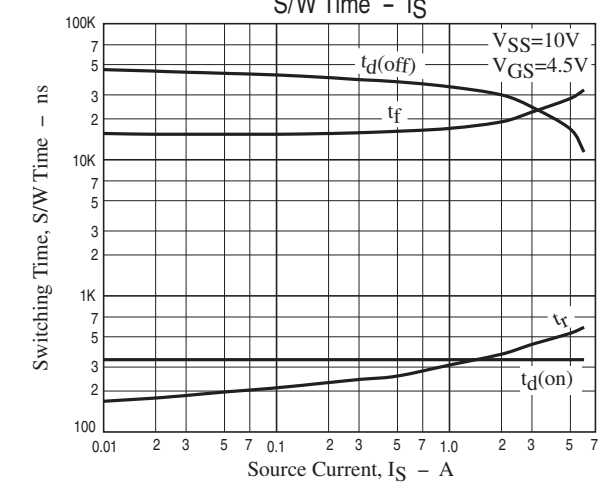
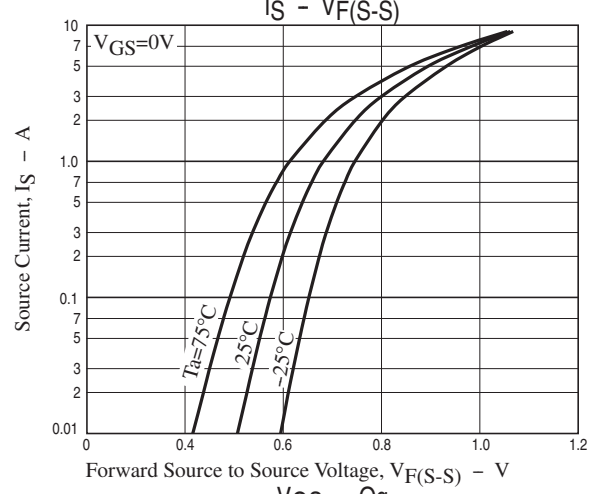
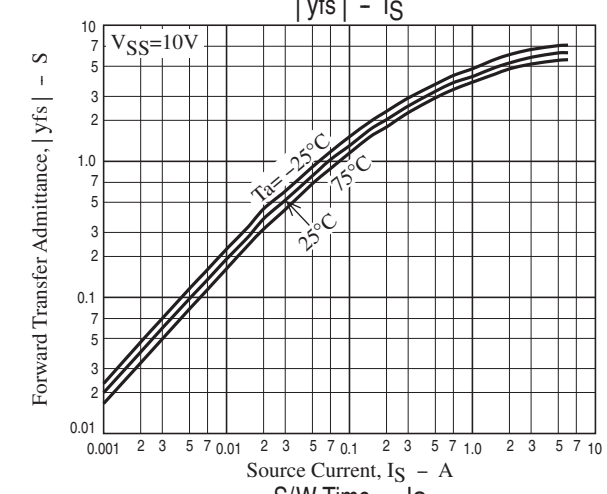
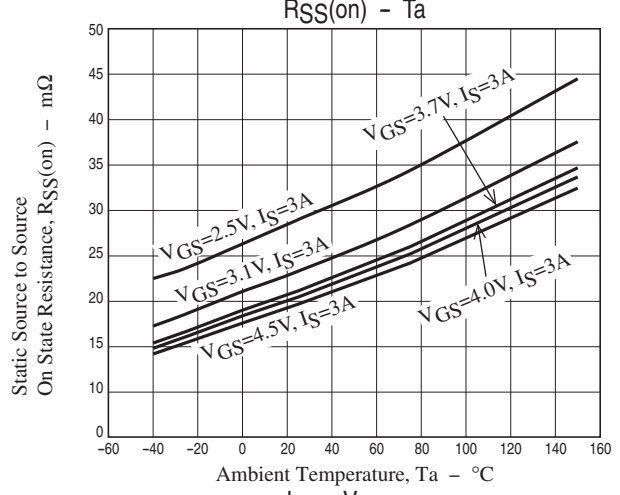
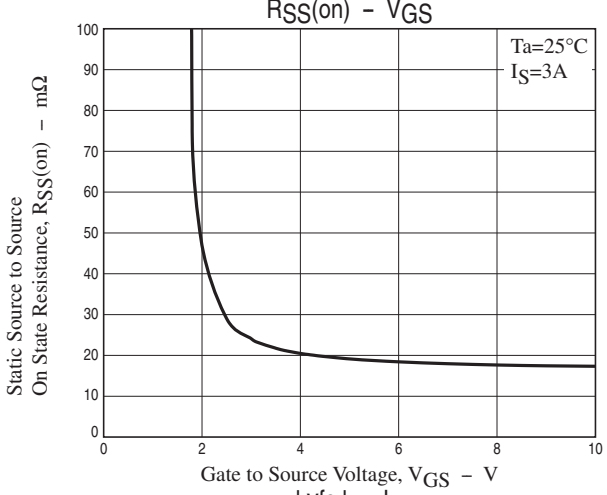
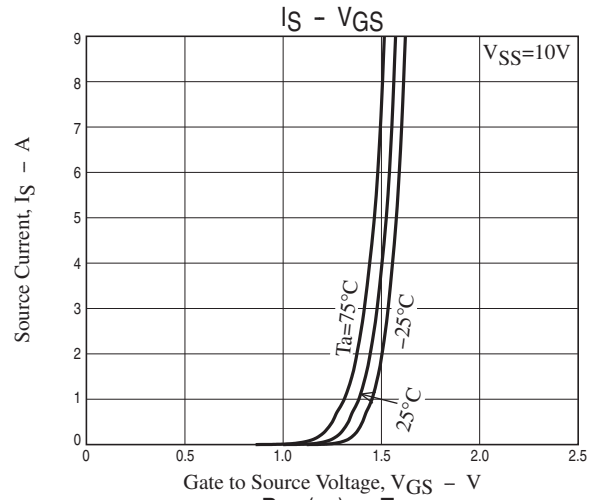
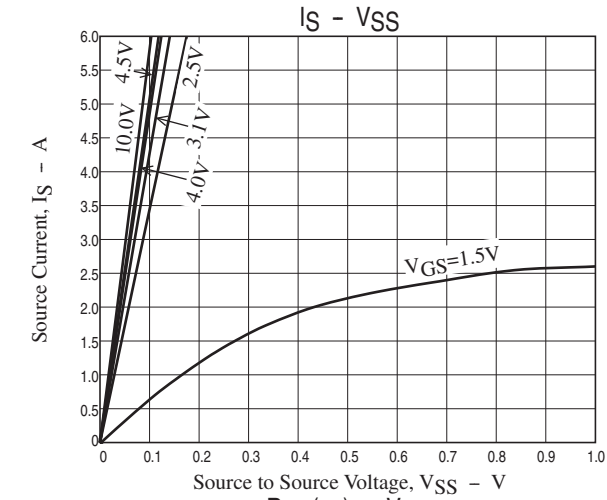

EFC4619R

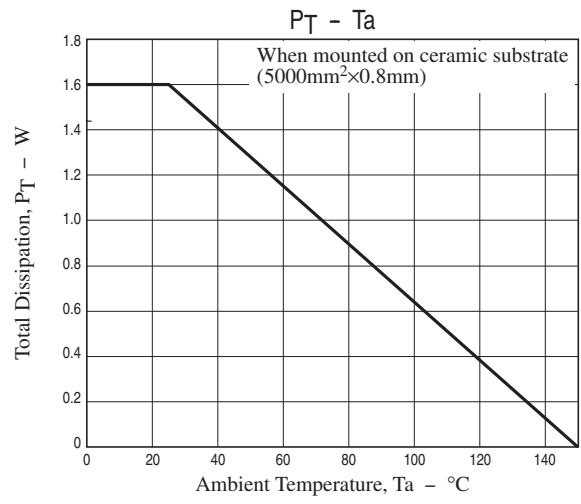
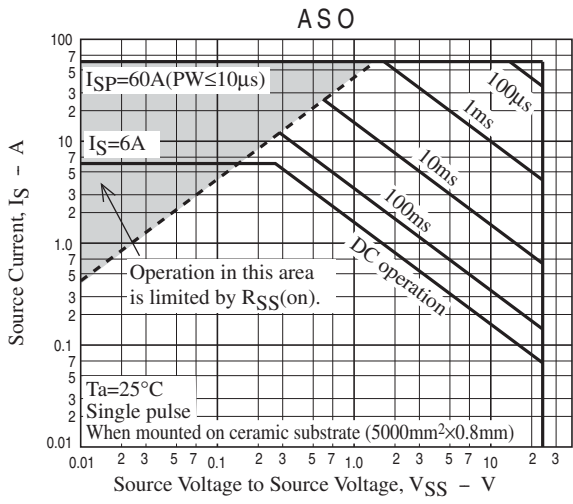

EFC4619R

Taping Specification

EFC4619R-TR

1. Taping Configuration

1-1. Carrier Tape Size (unit:mm)

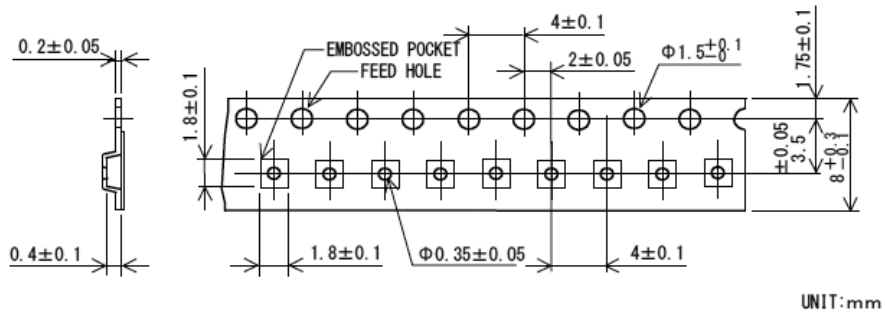

1-2. Device Placement Direction

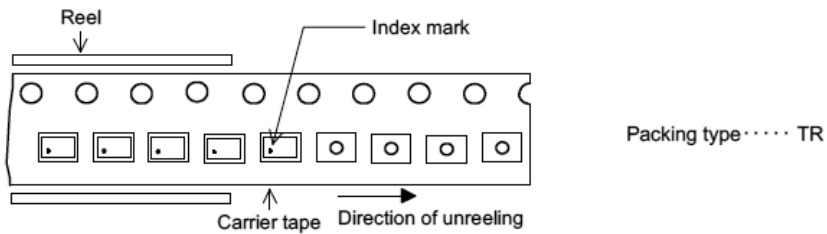

1-3. Leader portion and Trailer portion (unit:mm)

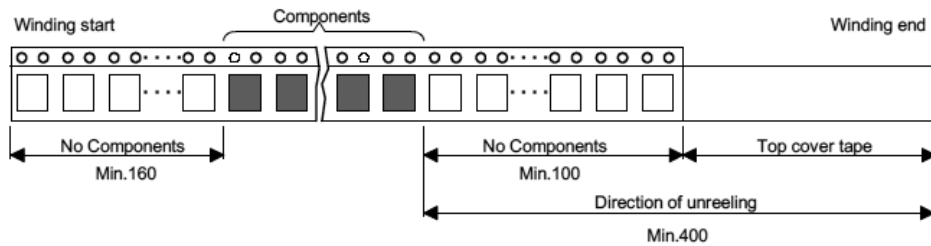

EFC4619R

Packing Format

Carrier Tape code	Package code	Maximum Number of devices contained. (pcs.)			Packing Format	
		Reel	Inner box		Inner box BOX(C-1)	
1818X04	EFCP1616-4CE-022	5,000	25,000		5reels contained. Dimensions:mm 183×72×185	

MPN Label

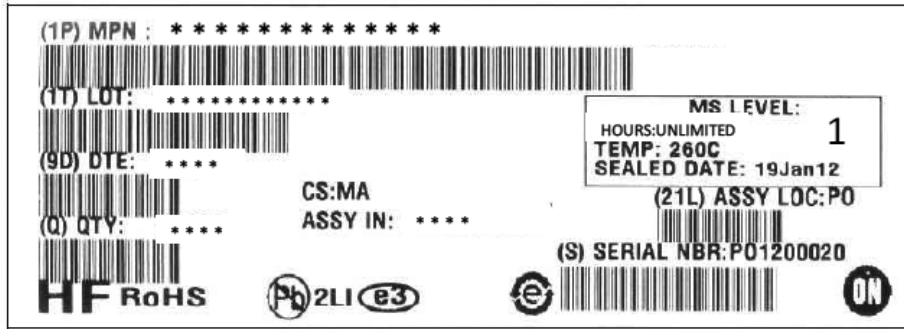

Packing Method

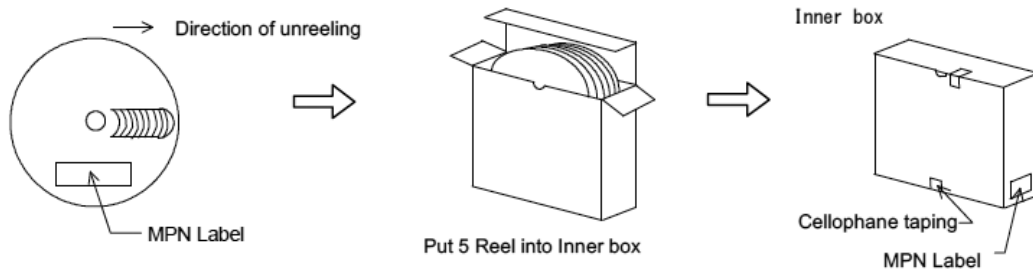

EFC4619R

Outline Drawing

EFC4619R-TR

Land Pattern Example

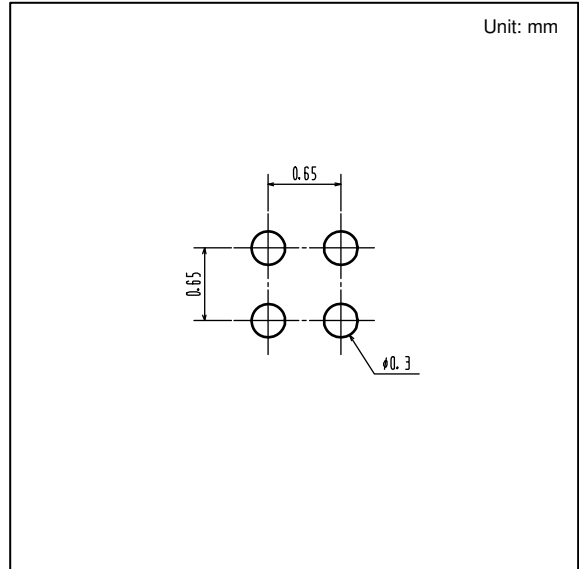
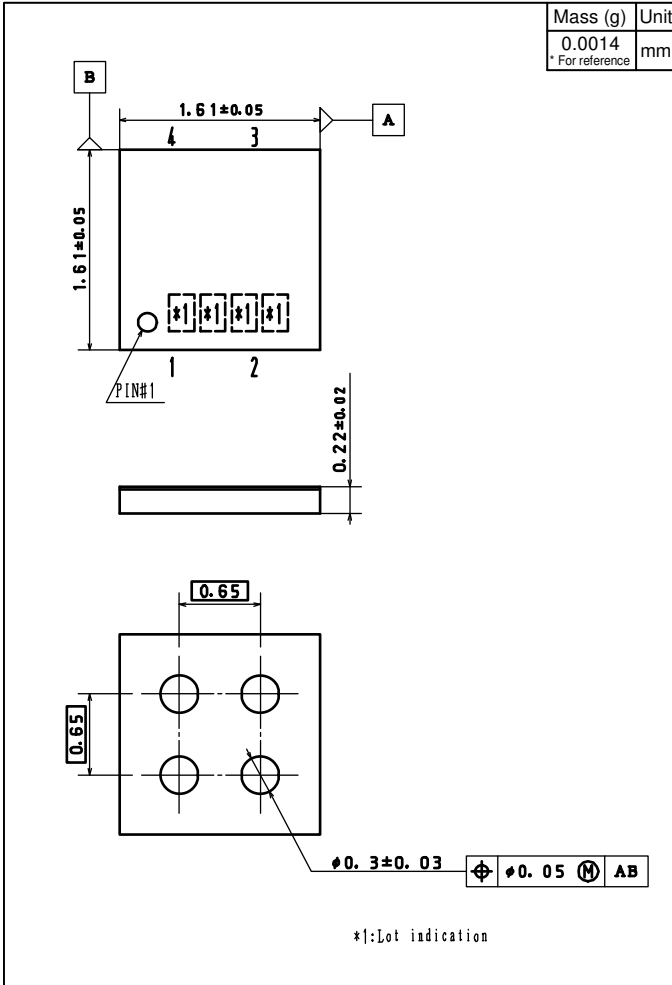

Note on usage : Since the EFC4619R is a MOSFET product, please avoid using this device in the vicinity of highly charged objects.

ON Semiconductor and the ON logo are registered trademarks of Semiconductor Components Industries, LLC (SCILLC). SCILLC owns the rights to a number of patents, trademarks, copyrights, trade secrets, and other intellectual property. A listing of SCILLC's product/patent coverage may be accessed at www.onsemi.com/site/pdf/Patent-Marking.pdf. SCILLC reserves the right to make changes without further notice to any products herein. SCILLC makes no warranty, representation or guarantee regarding the suitability of its products for any particular purpose, nor does SCILLC assume any liability arising out of the application or use of any product or circuit, and specifically disclaims any and all liability, including without limitation special, consequential or incidental damages. "Typical" parameters which may be provided in SCILLC data sheets and/or specifications can and do vary in different applications and actual performance may vary over time. All operating parameters, including "Typicals" must be validated for each customer application by customer's technical experts. SCILLC does not convey any license under its patent rights nor the rights of others. SCILLC products are not designed, intended, or authorized for use as components in systems intended for surgical implant into the body, or other applications intended to support or sustain life, or for any other application in which the failure of the SCILLC product could create a situation where personal injury or death may occur. Should Buyer purchase or use SCILLC products for any such unintended or unauthorized application, Buyer shall indemnify and hold SCILLC and its officers, employees, subsidiaries, affiliates, and distributors harmless against all claims, costs, damages, and expenses, and reasonable attorney fees arising out of, directly or indirectly, any claim of personal injury or death associated with such unintended or unauthorized use, even if such claim alleges that SCILLC was negligent regarding the design or manufacture of the part. SCILLC is an Equal Opportunity/Affirmative Action Employer. This literature is subject to all applicable copyright laws and is not for resale in any manner.