



Chipsmall Limited consists of a professional team with an average of over 10 year of expertise in the distribution of electronic components. Based in Hongkong, we have already established firm and mutual-benefit business relationships with customers from,Europe,America and south Asia,supplying obsolete and hard-to-find components to meet their specific needs.

With the principle of "Quality Parts,Customers Priority,Honest Operation,and Considerate Service",our business mainly focus on the distribution of electronic components. Line cards we deal with include Microchip,ALPS,ROHM,Xilinx,Pulse,ON,Everlight and Freescale. Main products comprise IC,Modules,Potentiometer,IC Socket,Relay,Connector.Our parts cover such applications as commercial,industrial, and automotives areas.

We are looking forward to setting up business relationship with you and hope to provide you with the best service and solution. Let us make a better world for our industry!



## Contact us

Tel: +86-755-8981 8866 Fax: +86-755-8427 6832

Email & Skype: info@chipsmall.com Web: www.chipsmall.com

Address: A1208, Overseas Decoration Building, #122 Zhenhua RD., Futian, Shenzhen, China



## Introduction

This note describes the operation and the instruction for using the three kits developed for training and supporting the design of the solid state thin film battery EnFilm™ EFL700A39.

- The EFL700EVALKIT evaluation kit (order code: EFL700EVALKIT) allows to discover the operation of the EFL700A39 and to monitor the voltage and the charge/discharge current in real use-case condition. It includes one EnFilm™ load board and one EFL700PMB power management board (*Figure 1*).
- The EFL700PMB design-in kit (order code: EFL700PMB) includes one EFL700PMB board embedding all the necessary power management circuit around one EnFilm™ EFL700A39 (*Figure 2*).
- The new EFL1-NFC-PMB design-in kit (order code: EFL1-NFC-PMB) includes one EFL1-NFC-PMB board embedding a NFC contactless smart charger and an advanced ST ultra-low current consumption EnFilm™ power management solution on a tiny EFL700A39 footprint size board (*Figure 3*).

Both EFL700PMB and EFL1-NFC-PMB kits can be directly connected in the application for a fast evaluation and are also compatible with the EnFilm™ monitoring load board.

# Contents

- 1 General description and features ..... 4**
  - 1.1 EFL700 power management board (EFL700PMB) ..... 4
  - 1.2 The EFL1-NFC-PMB power management board ..... 4
  - 1.3 The EnFilm™ load board from EFL700EVALKIT ..... 5
- 2 The EFL700PMB power management board ..... 6**
  - 2.1 Pictures of the EFL700PMB board ..... 6
  - 2.2 Block diagram of the EFL700PMB board ..... 6
  - 2.3 Using the EFL700PMB board ..... 7
- 3 The EFL1-NFC-PMB power management board ..... 8**
  - 3.1 Pictures of the EFL1-NFC-PMB board ..... 8
  - 3.2 Block diagram of the EFL1-NFC-PMB board ..... 8
  - 3.3 Using the EFL1-NFC-PMB board ..... 9
- 4 The EFL700EVALKIT evaluation kit ..... 11**
  - 4.1 Description of the complete evaluation kit with the EFL700PMB connected to the EnFilm™ load board (LB) ..... 11
  - 4.2 Block diagram of the complete evaluation kit with the EFL700PMB connected to the EnFilm™ load board ..... 12
  - 4.3 Using the complete EFL700EVALKIT evaluation kit ..... 13
  - 4.4 Block diagram of the EFL1-NFC-PMB connected to the EnFilm™ load board 14
  - 4.5 Use case with a PV energy harvester and the EFL700PMB board ..... 15
- 5 Electrical schematics ..... 17**
  - 5.1 EFL700PMB power management board ..... 17
  - 5.2 EnFilm™ load board from EFL700EVALKIT ..... 18
  - 5.3 EFL1-NFC-PMB power management board ..... 19
- 6 Bill of materials ..... 20**
- 7 Revision history ..... 23**



Figure 1. Picture of the EFL700EVALKIT kit

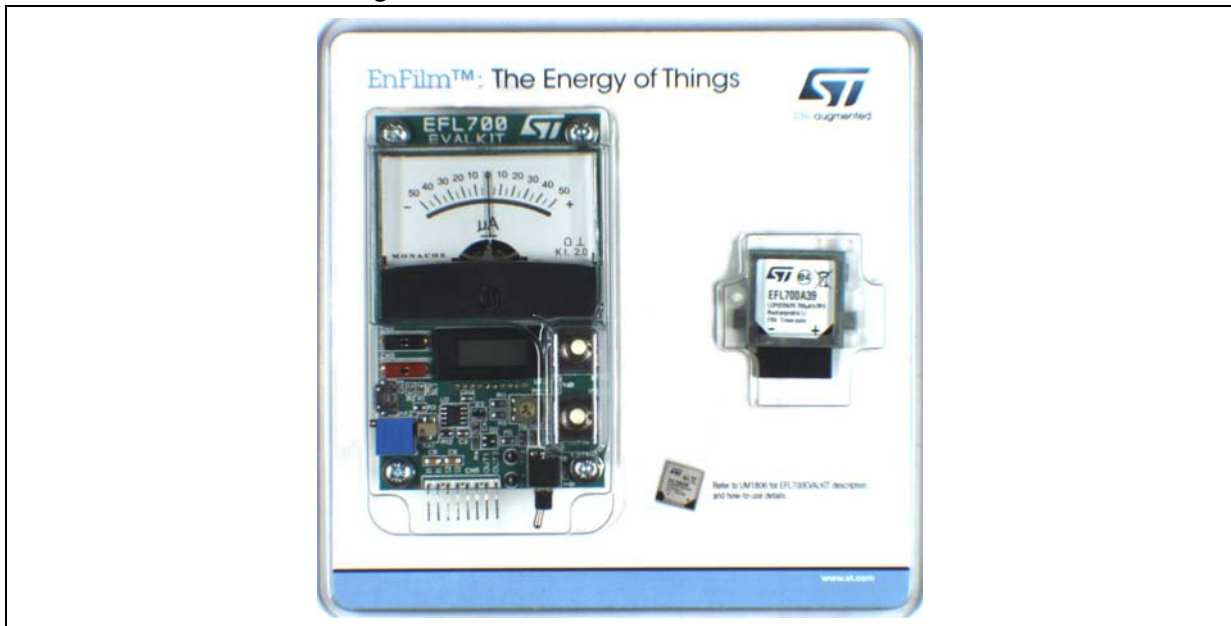

Figure 2. EFL700PMB kit



Figure 3. EFL1-NFC-PMB kit



# 1 General description and features

The EFL700A39 EnFilm™ battery brings many benefits compared to conventional battery:

- Low thickness
- Low self-discharge
- Extremely long calendar and cycle life time
- High safety with no risk of burning or explosion

EFL1-NFC-PMB, EFL700PMB and EFL700EVALKIT kits were developed to help designers to evaluate the charge and discharge performances of the EnFilm™ EFL700A39 with a proper setup of power management.

The EFL700PMB and the EFL1-NFC-PMB kits include each one PCB: Each power management board has the same size as the EFL700A39 battery which is mounted on the top side, it can be charged by different type of energy source and can be connected to any kind of load with its own power management circuit.

Whatever the harvester and load system are, both EFL700PMB and EFL1-NFC-PMB allow a safe and efficient use of the EFL700A39 micro-battery.

## 1.1 EFL700 power management board (EFL700PMB)

- Manages the charge voltage regulation and the deep discharge protection of the EFL700A39
- Includes buffer capacitors to sustain high pulsed discharge current. Buffer capacitors can be disconnected with the switch SW1
- Supports the charge through an external energy harvesting source (5.0V MIN)

The EFL700PMB can be used in association with an USB port, a photovoltaic panel or any kind of harvester with its own power management.

## 1.2 The EFL1-NFC-PMB power management board

- Includes an embedded NFC contact-less smart charger based on the ST M24LR04E-R dynamic NFC/RFID tag IC for easy and fast EnFilm™ charge
- Manages the charge voltage regulation and the deep discharge protection of the EFL700A39 using an advanced ST ultra-low current consumption power management IC
- Includes also an additional power input pin for wire plugging of an external charger like an energy harvesting source or any other power supply (4.5V MIN).

The EFL1-NFC-PMB can be powered by a NFC/RFID reader, a NFC-enabled phone, a photo-voltaic panel or any kind of harvester with its own power management.

### 1.3 The EnFilm™ load board from EFL700EVALKIT

This board is included inside the EFL700EVALKIT kit together with an EFL700PMB power management board. The EnFilm™ load board embeds:

- An analog ammeter and a digital voltmeter allowing the user to monitor:
  - The current delivered by the source by pressing PB1.
  - The current going through the EFL700A39 battery by pressing PB2.
  - The battery voltage
- A pulsed load emulator with the possibility to adjust the pulsed load cyclic ratio. Its features are:
  - Enable / disable function by toggling the switch SW3.
  - Default pulsed load current set to 5 mA during a pulse time of 100 ms every 10 s.
  - Tunable pulse duration from 1 ms up to 100 ms through RA1 rheostat.
  - Tunable pulse repetition time from 1 s up to 10 s through RA2 rheostat.

The LB can be powered via 2 mm banana connectors or a micro-USB plug.

The EFL1-NFC-PMB board is compatible with the LB and will operate in the same way than the EFL700PMB when connected to the LB.

The use of the EnFilm™ load board is recommended to get familiar with operations of both EFL700PMB and EFL1-NFC-PMB power management boards and thus with the EFL700A39 electrical management characteristics.

## 2 The EFL700PMB power management board

### 2.1 Pictures of the EFL700PMB board

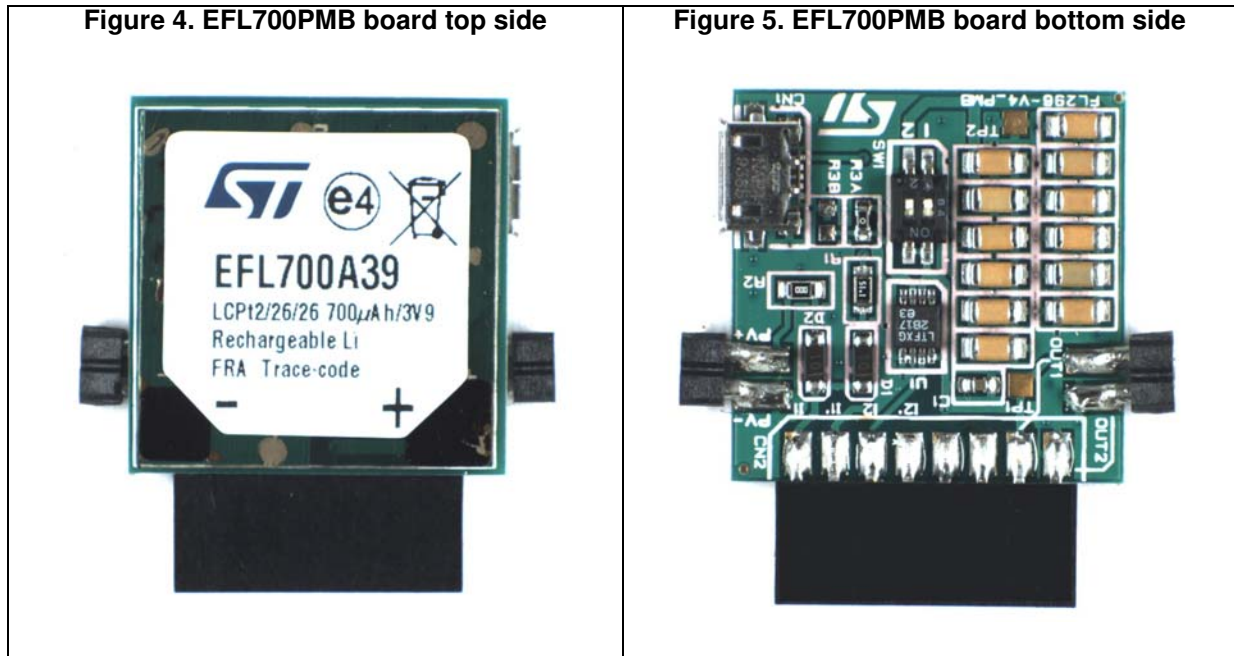

### 2.2 Block diagram of the EFL700PMB board

Figure 6. Synoptic of the EFL700PMB board

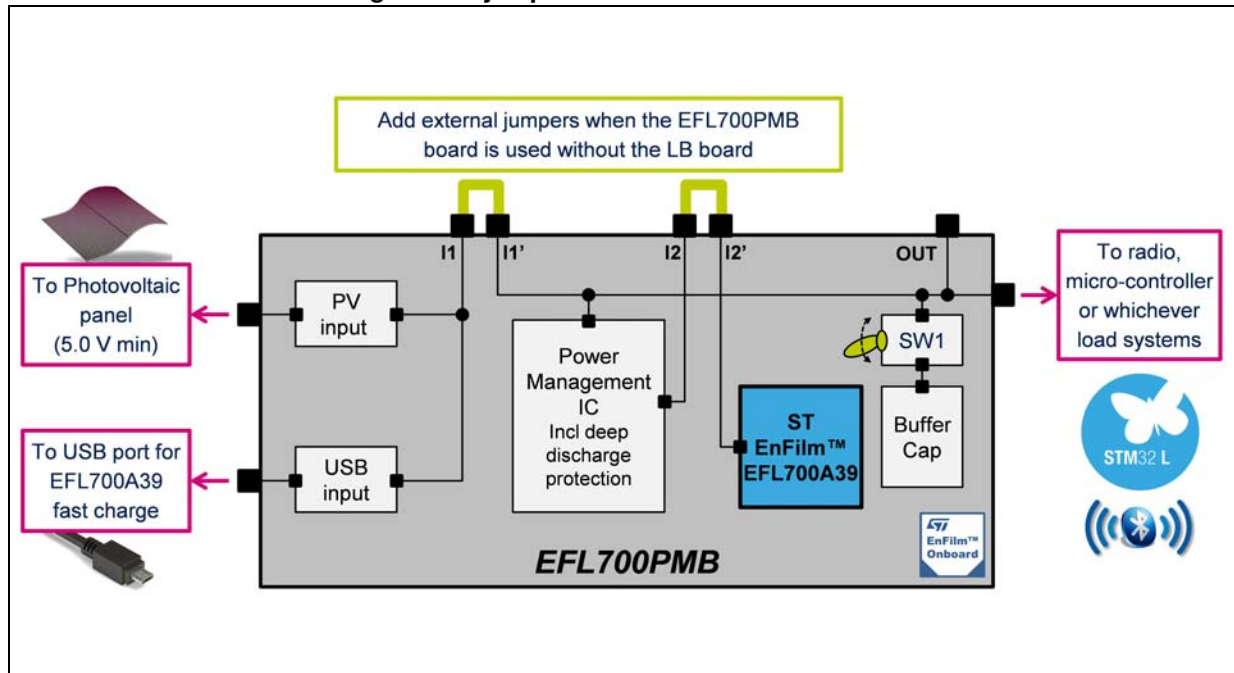

## 2.3 Using the EFL700PMB board

The EFL700PMB board can be used separately in your own application to supply areal IoT (Internet of Things) application case with a micro-controller and radio circuit load.

For this, it will be necessary first to jump strap the I1 to I1' pins and I2 to I2' pins as shown below in [Figure 7](#).

**Figure 7. Description of the EFL700PMB board**

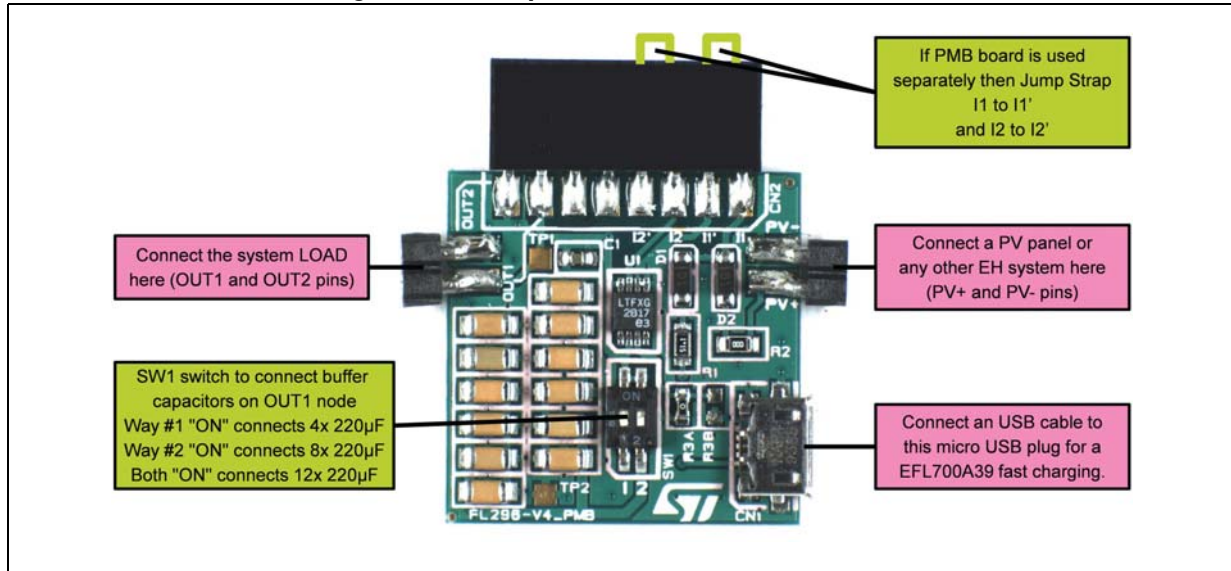

The EFL700PMB board characteristics are the following at 25°C:

- 4.2 V output voltage limitation during the charge of the battery
- Deep discharge battery protection when output voltage gets down to 3.2 V
- USB fast charge

When turning “ON” both SW1 switches on the EFL700PMB board, the user connects 12 SMD buffer capacitors mounted on the PMB board to the output node. Buffer capacitors work in parallel with the EFL700A39 micro-battery and are dedicated for high current pulse applications. As shown in the [Figure 7](#), SW1 is a two-way switch. Turning “ON” the way #1 connects 4 of the 12 buffer capacitors. Turning “ON” the way #2 connects 8 of the 12 buffer capacitors. Each of the 12 buffer capacitor is a 220  $\mu\text{F}$  1206 HiCap MLCC capacitor resulting actually in a typical 800  $\mu\text{F}$  capacitance value under 4 V bias when all buffer cap are connected.

An external PV panel or any other energy harvesting source connected on PV+ and PV- pins should have an output voltage above 5.0 V to enable the EnFilm™ charge.



### 3 The EFL1-NFC-PMB power management board

#### 3.1 Pictures of the EFL1-NFC-PMB board

Figure 8. EFL1-NFC-PMB board top side

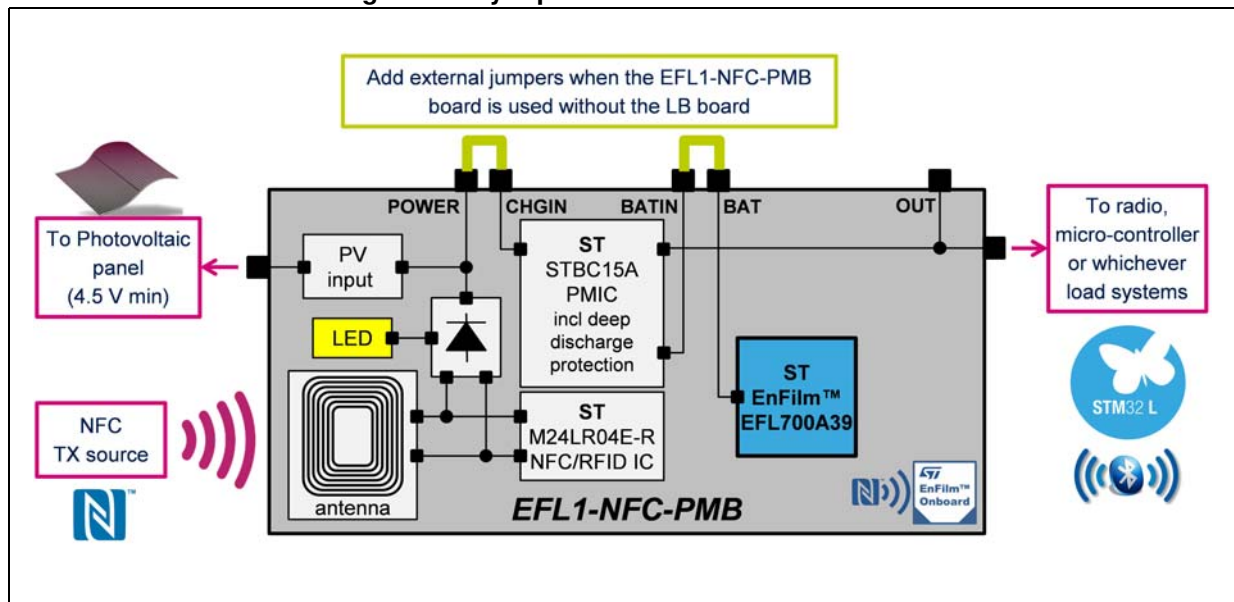

Figure 9. EFL1-NFC-PMB board bottom side



#### 3.2 Block diagram of the EFL1-NFC-PMB board

Figure 10. Synoptic of the EFL700PMB board



### 3.3 Using the EFL1-NFC-PMB board

The EFL1-NFC-PMB board can be used with the EnFilm™ load board or separately in your own application. It can be plugged directly in your system to supply a real IoT (Internet of Things) device with a micro-controller and radio circuit load.

For this, it will be necessary to jump strap POWER to CHGIN pins and BATIN to BAT pins as shown below in the [Figure 11](#).

**Figure 11. Description of the EFL1-NFC-PMB board**

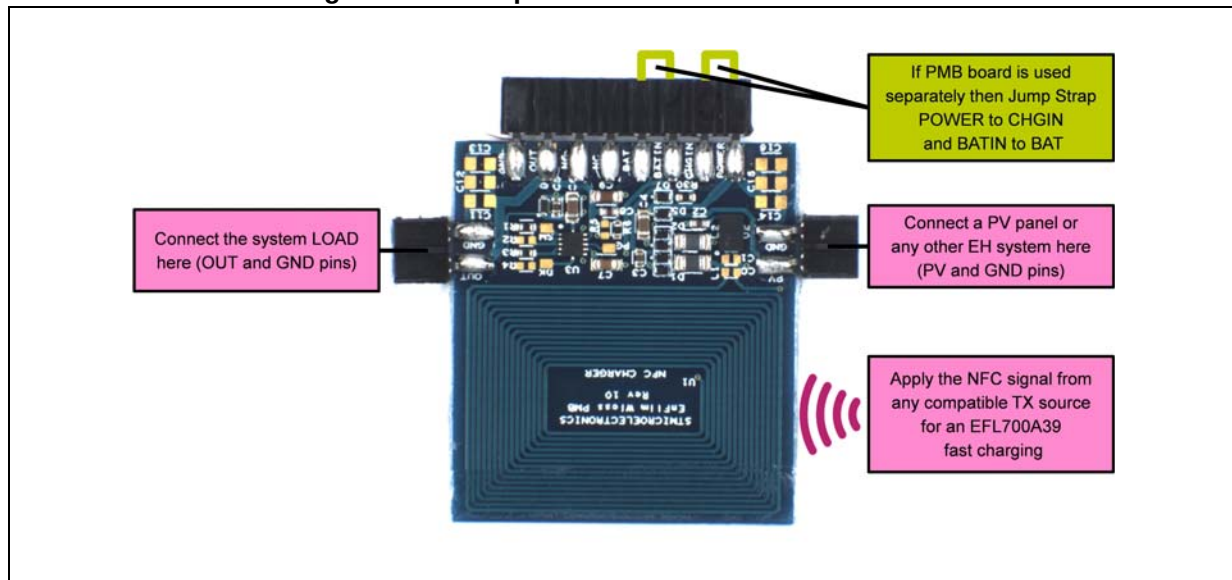

The EFL1-NFC-PMB board characteristics are the following at 25°C:

- 4.2 V output voltage limitation during the charge of the battery
- Deep discharge battery protection when output voltage gets down to 3.3 V
- Easy NFC contact-less fast charge with LED indicator on top EnFilm™ side
- Ultra-low nano-current consumption on EnFilm™:
  - 350 nA MAX in battery power supply mode (power backup)
  - 10 nA MAX in shelf-mode or brownout protection
- Ultra-low micro-power consumption on external charger input:
  - 4.5 μW MIN power need to start charging with an energy harvesting source

An external PV panel or any other energy harvesting source connected on PV and GND pins should have an output voltage above 4.5 V to enable the EnFilm™ charge.

The EFL1-NFC-PMB board can be wirelessly charged thanks to the embedded NFC/RFID smart charger. This unique feature allows easy and fast EnFilm™ charge thanks to any NFC/RFID reader or NFC-enabled phone.

For quick start, ST recommends the use of the RF transceiver demonstration board included inside the ST M24LR-DISCOVERY kit (order code: M24LR-DISCOVERY).

For detailed information, refer to the ST UM1589 user manual available on [www.st.com](http://www.st.com).

The RF transceiver board is an USB RFID reader demonstration board that includes the CR95HF 13.56-MHz multi-protocol contact-less transceiver. This board has to be plugged in to a PC and comes with a demonstration software.

**Figure 12. RF transceiver demonstration board**

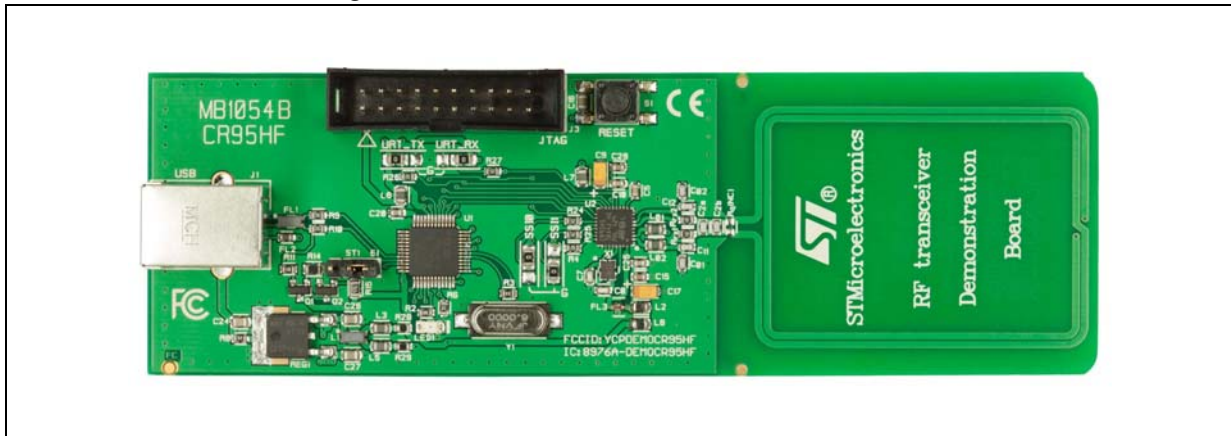

- Using the EFL1-NFC-PMB board with the ST RF transceiver demonstration board
  - a) Download and install the M24LR/CR95 application software setup file [STSWM24LR011] available in dedicated web pages on [www.st.com](http://www.st.com).
  - b) 2.Connect the RF transceiver demo board to a PC with a USB cable.
  - c) Launch setup.exe, and select CR95HF Demo Kit. Then, open the Demo NDEF messages menu or the Image Transfert Application menu for example.
  - d) Place the EFL1-NFC-PMB board antenna close to the RF transceiver demo board antenna.

The RF transceiver board powers the EFL1-NFC-PMB board and the green LED is lighting.

- Using the EFL1-NFC-PMB board with Android NFC phones
  - a) Enable NFC communication on your phone (Settings >Wireless and Networks > NFC).
  - b) Download the NfcV-Reader Application from Google Play Store.
  - c) Launch the NfcV-Reader application.
  - d) Place the phone's NFC antenna close to the EFL1-NFC-PMB board antenna.

The phone powers the EFL1-NFC-PMB board and the green LED is lighting.

Please note that performance may vary depending on the NFC phone and its RF management system.

## 4 The EFL700EVALKIT evaluation kit

### 4.1 Description of the complete evaluation kit with the EFL700PMB connected to the EnFilm™ load board (LB)

Figure 13. Description of the EFL700PMB connected to the EnFilm™ load board

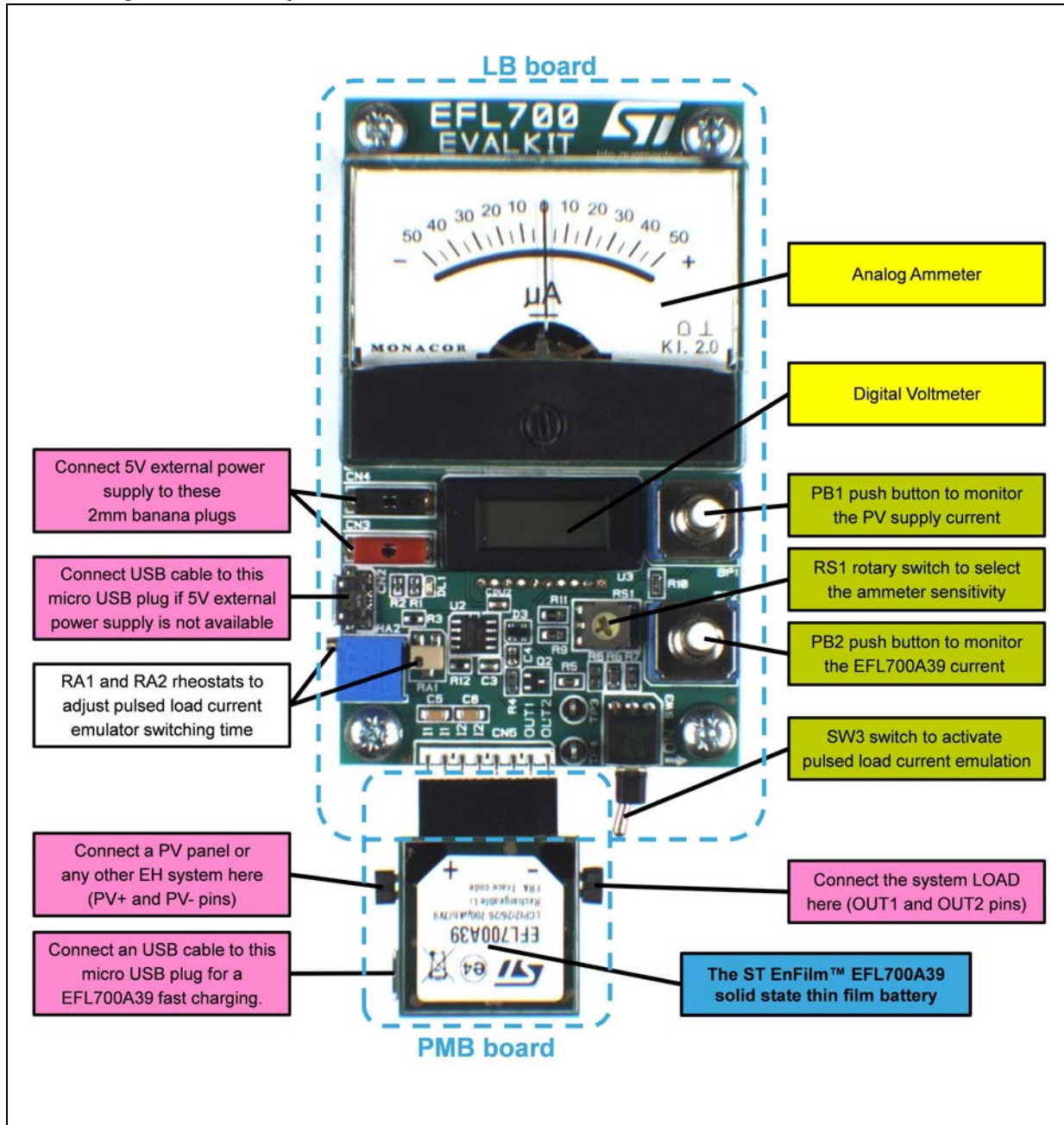



### 4.2 Block diagram of the complete evaluation kit with the EFL700PMB connected to the EnFilm™ load board

Figure 14. Synoptic of the EFL700EVALKIT kit

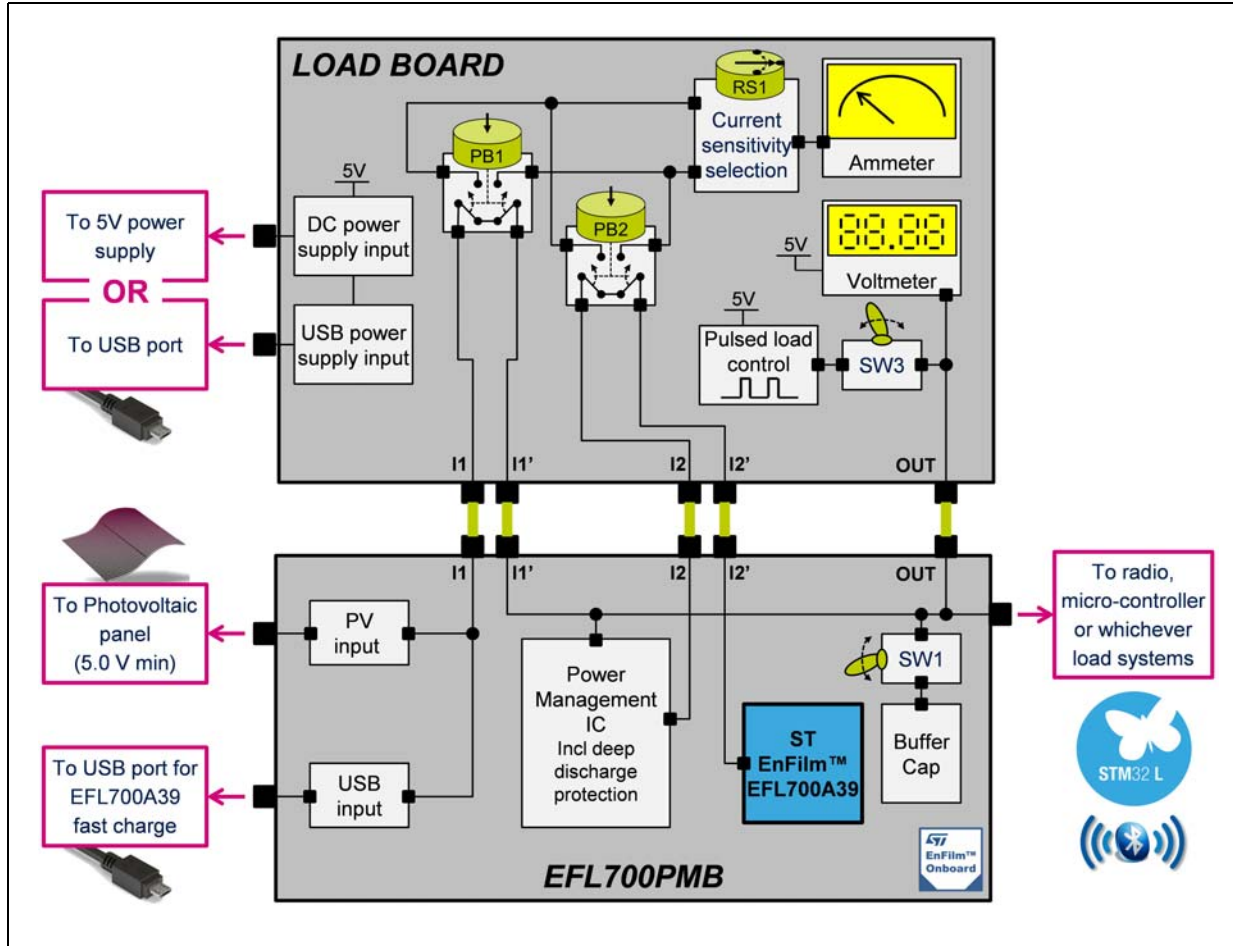

### 4.3 Using the complete EFL700EVALKIT evaluation kit

The complete discovery kit gives the possibility to monitor the EFL700A39 charging and discharging currents as if the EFL700A39 battery was used in a real case application with high pulse current load. It also helps to monitor the charging current delivered by an external charger like an energy harvesting device or an USB port.

First connect +5 V power supply on the LB board via 2 mm banana plugs or USB connector. Toggle the SW3 switch to the left position in order to switch "OFF" the pulsed load emulator operation.

Then, connect an external PV panel or any other energy harvesting device having an output voltage above 5 V to the left side connector of the EFL700PMB board as shown in the [Figure 13](#) (PV+ and PV- pins).

In order to monitor the current delivered by the PV through the analog ammeter, press the PB1 push button. The ammeter sensitivity can be adjusted by selecting the correct position of the RS1 rotary switch (depending on the PV current capability):

- Position 1: "10" marking on the ammeter means 10 mA current is flowing.
- Position 2: "10" marking on the ammeter means 1 mA current is flowing.
- Position 3: "10" marking on the ammeter means 100  $\mu$ A current is flowing.

Pressing the PB2 push button will show through the ammeter the current that goes in or out of the EFL700A39 micro-battery.

The digital voltmeter indicates the charging voltage of either both EFL700A39 and buffer capacitor when SW1 switch is "ON" or EFL700A39 alone when SW1 switch is "OFF". This digital voltmeter shall indicate +4.2 V when the EFL700A39 is fully charged.

By turning "ON" the SW3 switch (right position), a current burst operation mode is emulated (default settings: 5 mA / 100 ms every 10 s). In order to see the response of the PMB board, press PB1 or PB2 (never press both at the same time). This will show how the charger and PMB work together. If the charge source does not provide enough current, the PMB board will supply burst current until the EFL700A39 voltage gets down to its security range. Indeed, when the battery voltage falls below 3.2 V the power management IC embedded on the PMB board will disconnect the EFL700A39 in order to prevent it from deep discharge.

The adjustment of the pulsed load duty cycle can be performed with RA1 and RA2 rheostats. RA1 controls the pulse duration whereas RA2 controls the pulse repetition time. A probe scope can be connected between TP3 and TP4 test points to tune the switching time of the pulse load.

If for any reason there is a need to fast charge the EFL700A39 - and buffer capacitors if connected - then users can easily connect the EFL700PMB board micro USB plug to an external USB port.

### 4.4 Block diagram of the EFL1-NFC-PMB connected to the EnFilm™ load board

The EFL1-NFC-PMB board is compatible with the EnFilm™ load board and will operate in the same way than the EFL700PMB when connected to the EnFilm™ load board.

Figure 15. Synoptic of the EFL1-NFC-PMB connected to the EnFilm™ load board

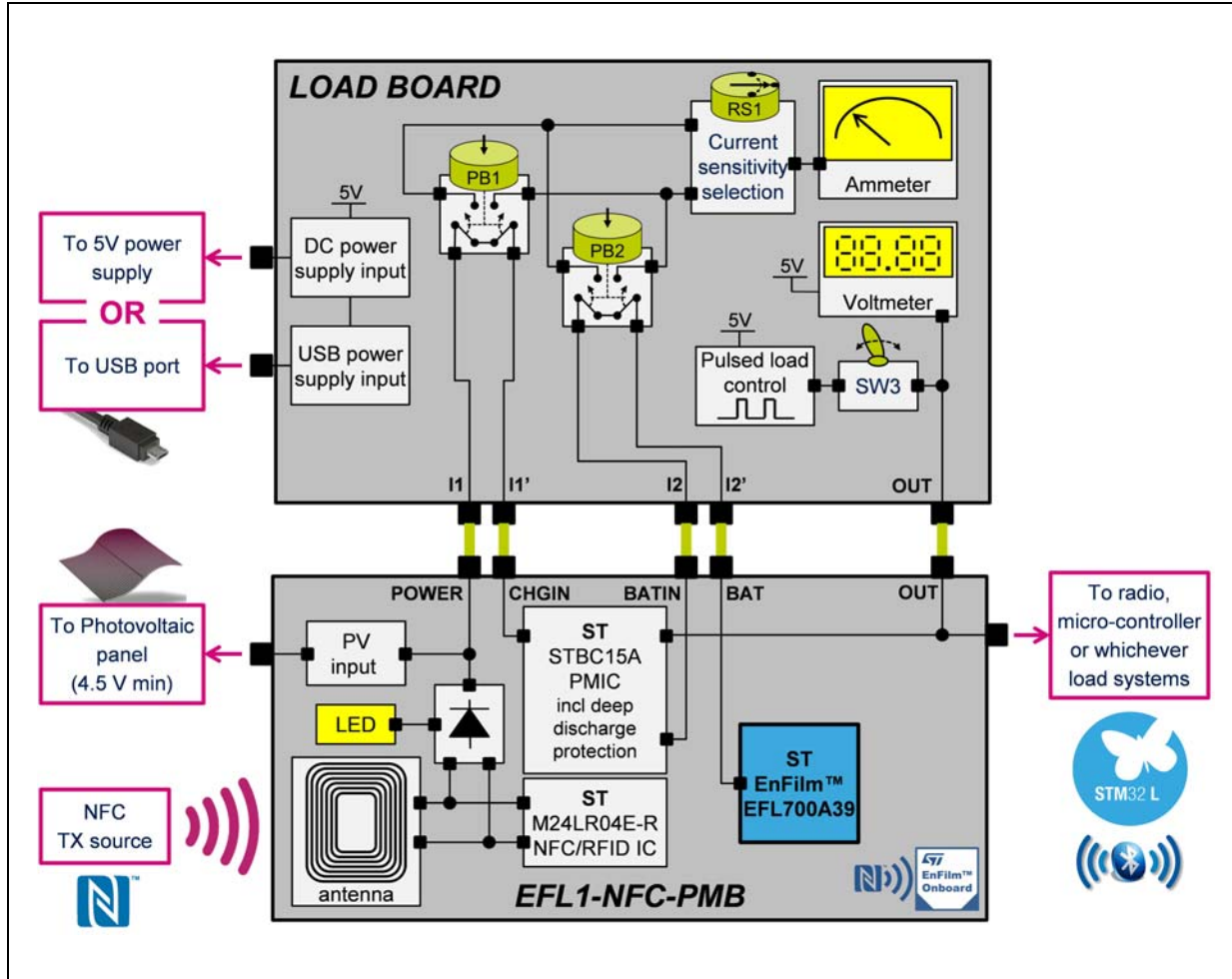

## 4.5 Use case with a PV energy harvester and the EFL700PMB board

### Step 1: Control of the efficiency of the PV energy harvester

The load is disconnected. Pressing PB1 permits the user to monitor the current delivered by the PV energy harvester. Then, activate the pulsed load current emulation by toggling SW3 switch on the EnFilm™ load board

Figure 16. Step 1 schema and picture

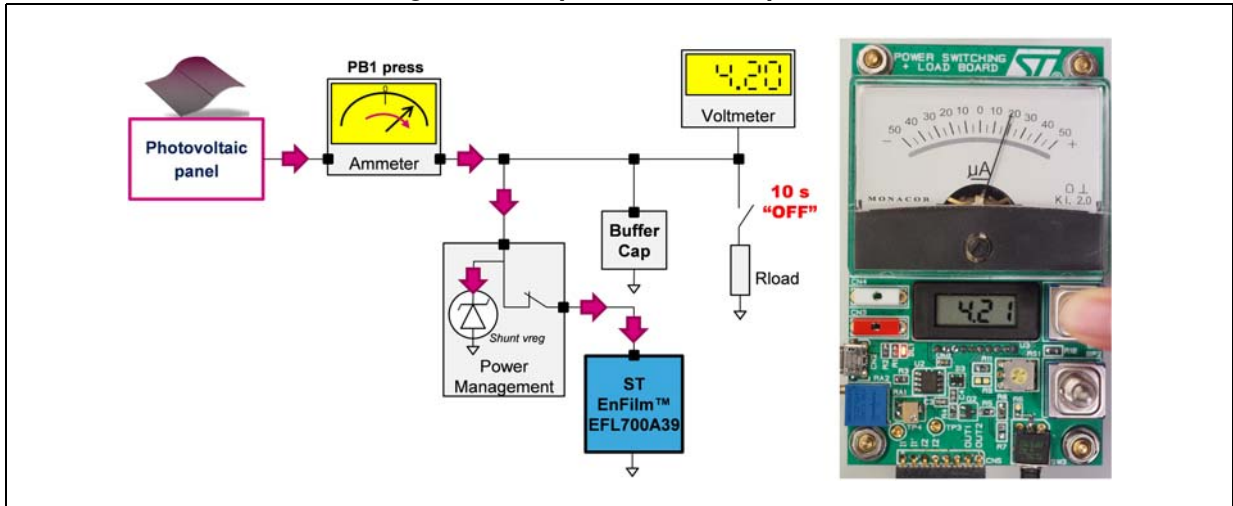

### Step 2: Connection of the load for 100 ms

PB2 monitors the current in the EFL700A39. The load is mainly supplied with buffer cap energy at the same time the EFL700A39 also participates. Voltage drops consequently from some tens of mV.

Figure 17. Step 2 schema and picture

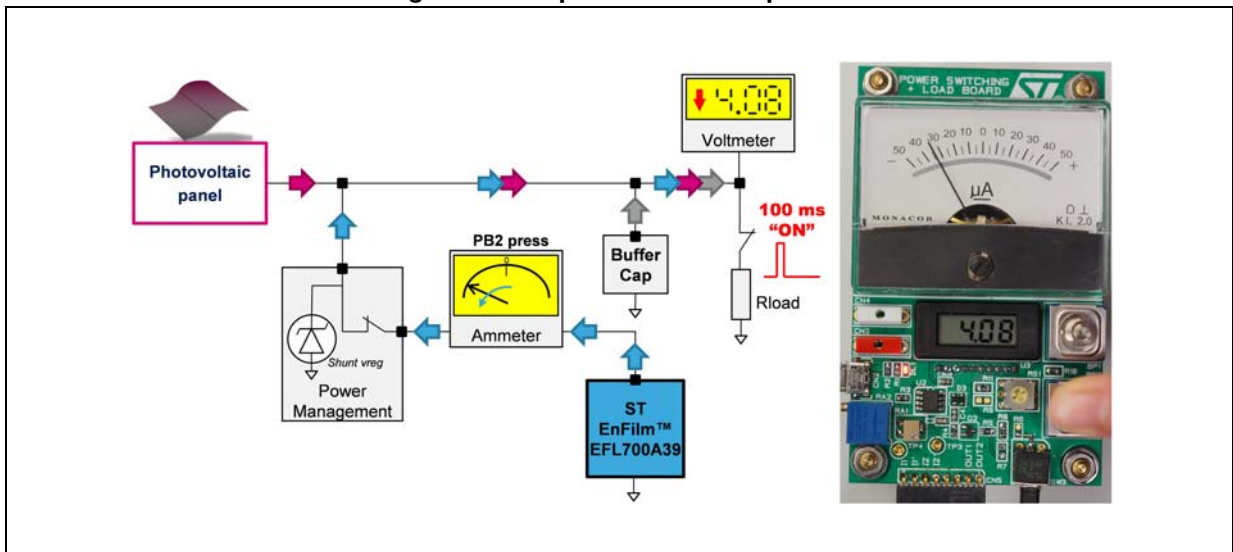



### Step 3: At the very beginning of disconnection of the load

PB2 monitors the current in the EFL700A39. The EFL700A39 is recharging the buffer cap, so current is still negative but reduces as the buffer cap gets charged.

Figure 18. Step 3 schema and picture

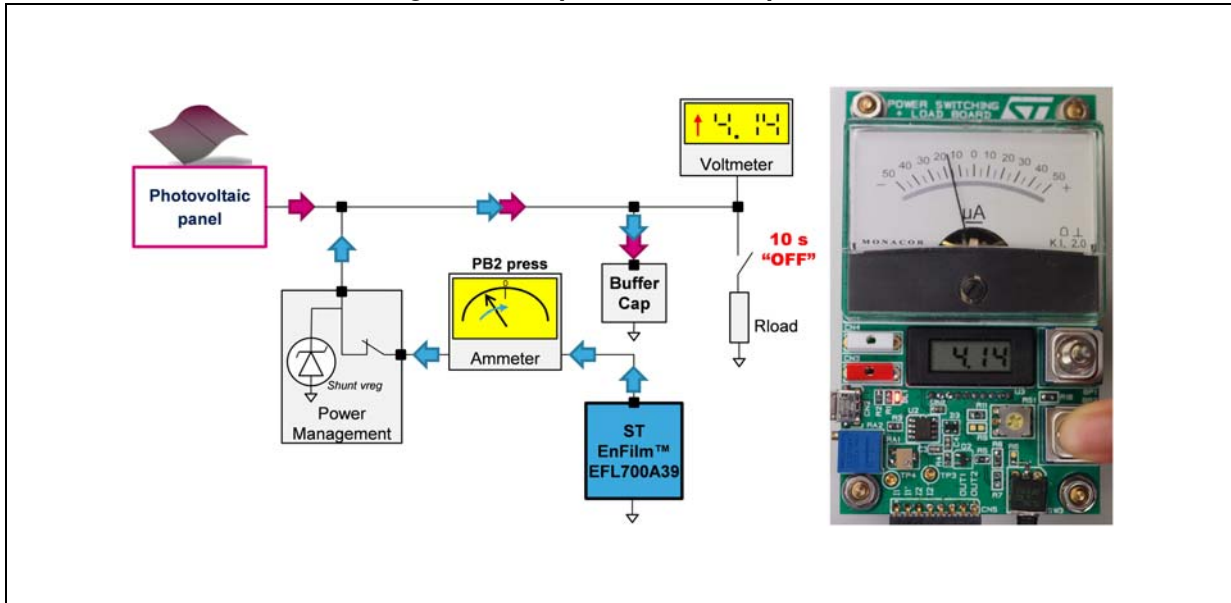

### Step 4: Load disconnected after a while

PB2 monitors the current in the EFL700A39. Once the buffer cap is charged, the EFL700A39 is getting charged at its turn by the PV harvesting system so the current is positive now until the voltage threshold of 4.2 V is reached.

Figure 19. Step 4 schema and picture

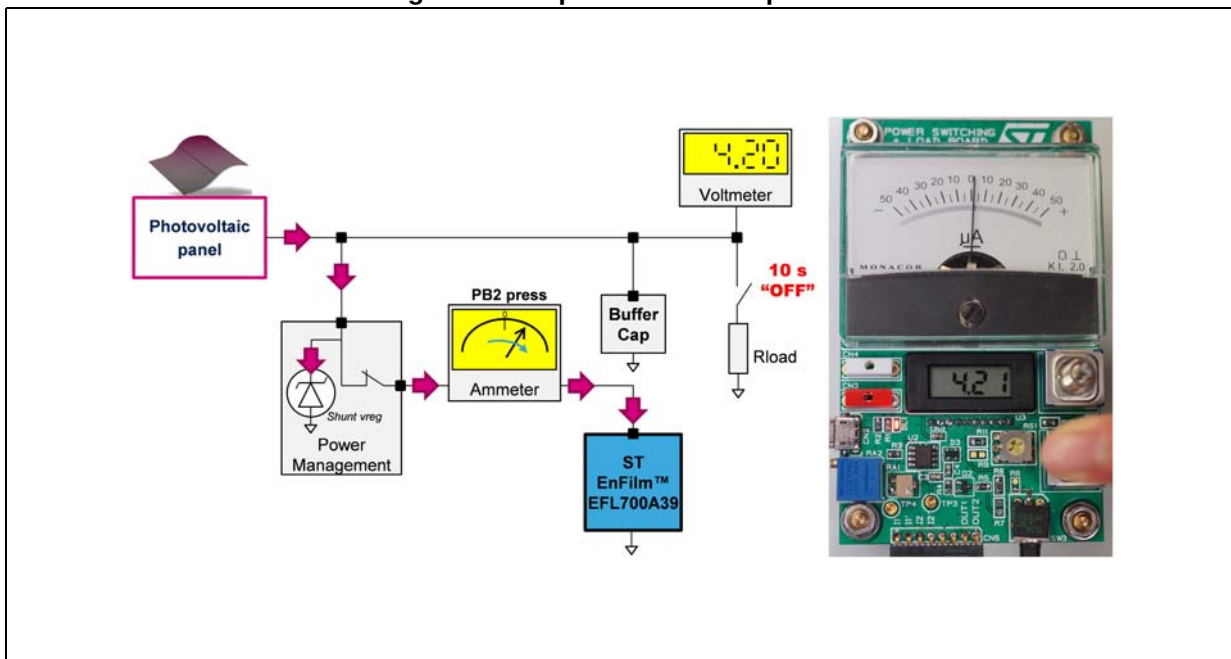



## 5.2 EnFilm™ load board from EFL700EVALKIT

Figure 21. Electrical schematic of the EnFilm™ load board

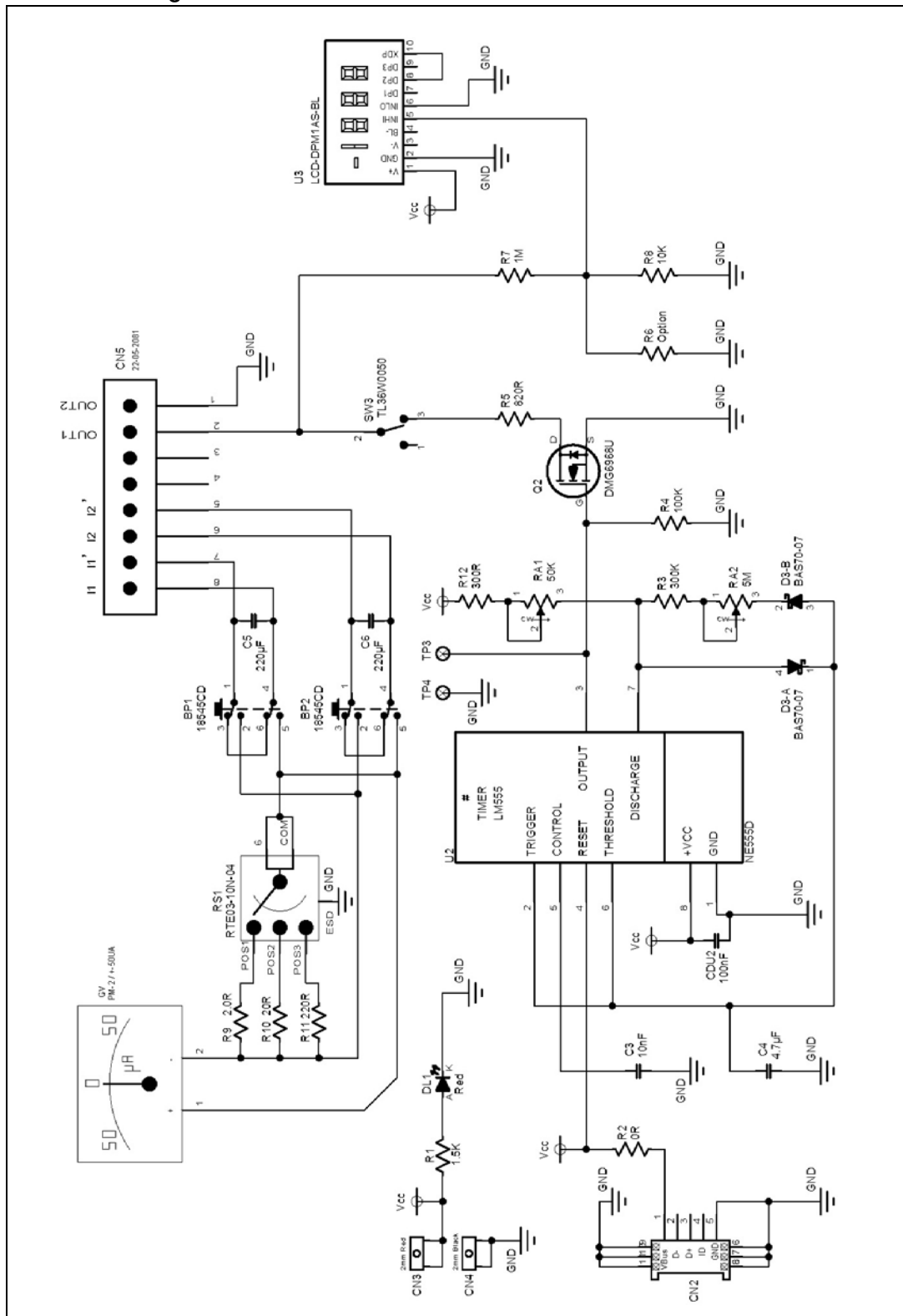

### 5.3 EFL1-NFC-PMB power management board

Figure 22. Electrical schematic of the EFL1-NFC-PMB board

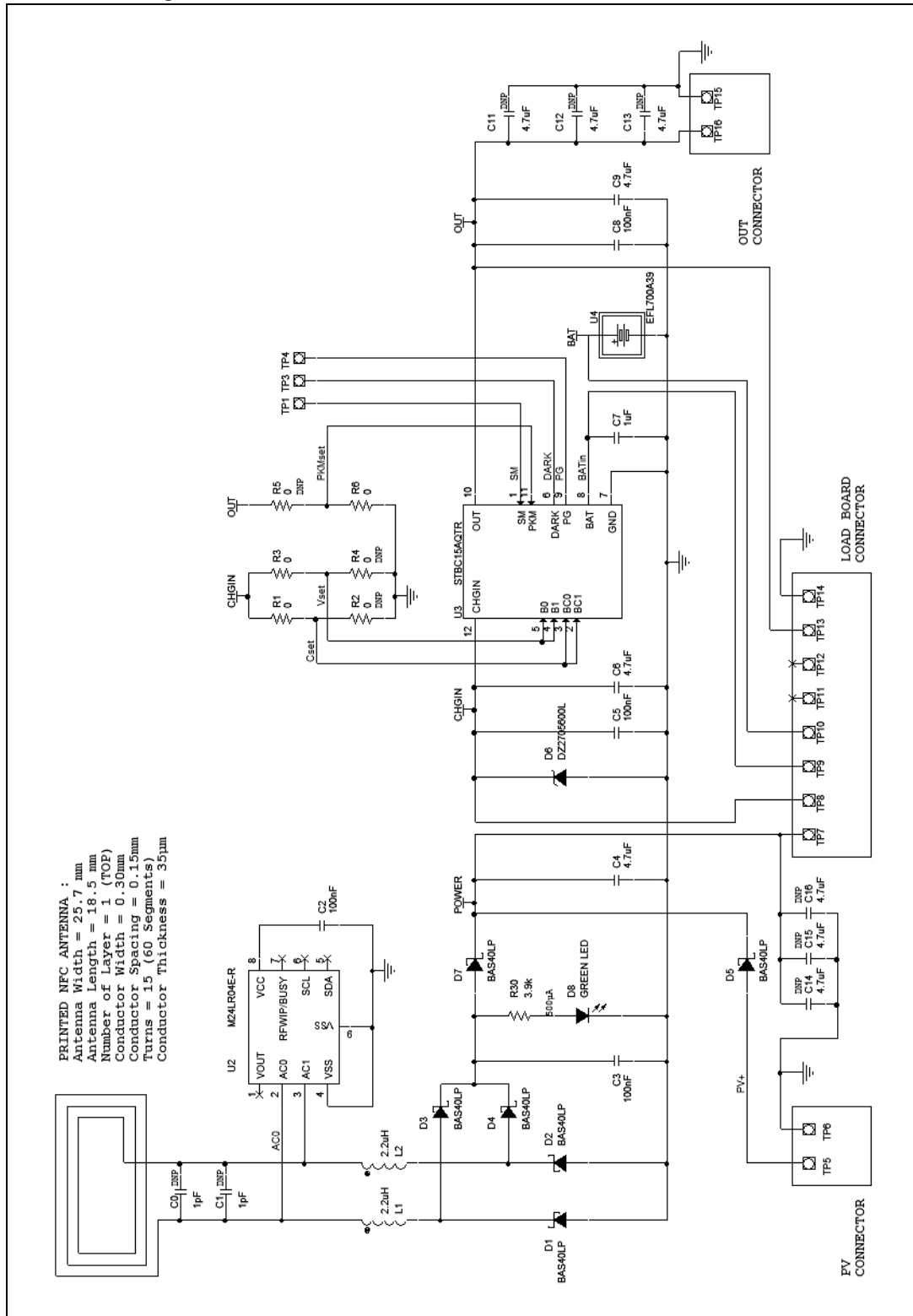



## 6 Bill of materials

Table 1. BOM of the EFL700PMB board

Reference	Designation	Supplier	Ref. parts	Value
BT	EnFilm™ - rechargeable solid state lithium thin film battery	STMicroelectronics	EFL700A39	700µA.h / 3.9 V
C1	Ceramic capacitor	AVX	06033D105KAT2A	1 µF
C2-C13	Ceramic buffer capacitors	MURATA	GRM31CR60J227M	8 x 220 µF
CN1	Connector Micro-USB	TE Connectivity	1981584-1	
CN2	Connector board-to-board	MULTICOMP	2212S-08SG-85	8 way / 2.54 mm pitch
D1	Diode	MULTICOMP	1N4148W	
D2	Diode	MULTICOMP	1N4148W	
OUT1, OUT2	Connector	Winslow	W35532TRC	2 way / 2.54 mm pitch
PVP, PVM	Connector	Winslow	W35532TRC	2 way / 2.54 mm pitch
R1	Resistor	PANASONIC	ERJP06F51R1V	51.1 ohms / 0.5W
R2	Resistor	PANASONIC	ERJ6GEY0R00V	0 ohms
R3A	Resistor	PANASONIC	ERJ3GEY0R00V	0 ohms
R3B	optional / not populated			
SW1	DIP Switch	MULTICOMP	MCDHN-02F-T-V	2 way
U1	Shunt battery charger system with low battery disconnect	LINEAR TECHNOLOGY	LTC4071EMS8E	
PCB	PMB board	AXIANE		

Table 2. BOM of the EnFilm™ load board

Ref.	Designation	Supplier	Ref. parts	Value
BP1	SWITCH PUSH BUTTON	APEM	18545CD	
BP2	SWITCH PUSH BUTTON	APEM	18545CD	
C3	Ceramic Capacitor	AVX	06035C103JAT2A	10nF
C4	Ceramic Capacitor	KEMET	C0603C475K9PACTU	4.7µF
C5	Ceramic capacitor	MURATA	GRM31CR60J227M	220µF
C6	Ceramic capacitor	MURATA	GRM31CR60J227M	220µF
CDU2	Ceramic Capacitor	KEMET	C0603C104K4RACTU	100nF
CN2	Micro-USB SMD connector	TE Connectivity	1981584-1	
CN3	2mm Standard tip plug	WIMA	105-0752-001	Red
CN4	2mm Standard tip plug	WIMA	105-0753-001	Black
CN5	Board-to-Board Connector	MOLEX	22.05.2081	8 way / 2.54 mm pitch
D3	Schottky diodes	NXP	BAS70-07	
DL1	LED	WURTH	150060RS75000	Red
GV	Ammeter PM-2 / +-50UA	MONACOR	29.045	
Q2	N-Channel MOSFET	DIODES INC.	DMG6968U7	
R1	Resistor	BOURNS	CR0603FX1501ELF	1,5K ohms
R2	Resistor	BOURNS	CR0603J000ELF	0 ohms
R3	Resistor	PANASONIC	ERJ3EKF3003V	300K ohms
R4	Resistor	PANASONIC	ERA6ARW104V	100K ohms
R5	Resistor	PANASONIC	ERJU06F8200V	820 ohms
R6	optional / not populated			
R7	Resistor	PANASONIC	ERA6AEB105V	1M ohms
R8	Resistor	PANASONIC	ERA6AEB103V	10K ohms
R9	Resistor	PANASONIC	ERJ6RQF2R0V	2 ohms
R10	Resistor	PANASONIC	ERJ6ENF20R0V	20 ohms
R11	Resistor	VISHAY	CRCW0805220RFKEA	220 ohms
R12	Resistor	PANASONIC	ERJP03F3000V	300 ohms
RA1	Trimmer 50KOHM, 10%, 12TURN	BOURNS	3224X-1-503E	0-50K ohms
RA2	Trimmer 5MOHM, 10%, 25TURN	BOURNS	3299P-1-505LF	0-5M ohms
RS1	Rotary DIP Switch	C&K	RTE03-10N-04	
SW3	SPDT On-On Switch	APEM	TL36W0050	
U2	Precision Timer	STMicroelectronics	NE555D	
U3	Digital voltmeter	LASCAR	DPM 1AS-BL	
PCB	LB board	AXIANE		

**Table 3. BOM of the EFL1-NFC-PMB board**

Ref.	Designation	Supplier	Ref. parts	Value
C0,C1	CAP / optional / not populated			
C2,C3,C5,C8	CAP CER 0.1UF 50V 10% X7R	MURATA	GRM155R71H104KE14	100 nF
C4,C6,C9	CAP CER 4.7UF 10V 10% X5R	MURATA	GRM185R61A475KE11	4.7 uF
C11,C12,C13 C14,C15,C16	CAP / optional / not populated			
C7	CAP CER 1UF 25V 10% X5R	MURATA	GRM185R61E105KA12	1.0 uF
D1,D2,D3, D4,D5,D7	DIODE SCHOTTKY 40V 200MA	DIODES INC	BAS40LP-7	
D6	DIODE ZENER 5.6V 120MW	PANASONIC	DZ2705600L	
D8	LED GREEN 54MW 20MA	ROHMS	SML-P11MTT86	
L1,L2	IND 2.2UH 600MA 340 MOHM	MURATA	LQM21PN2R2MC0D	2.2 uH
R1,R3,R6	RES SMD 0.0 OHM 1/10W	MURATA	ERJ-2GE0R00X	0 Ohms
R30	RES SMD 20 KOhms 1% 1/10W	MURATA	ERJ-2RK2002X	20 KOhms
TP5,TP6	CONNECTOR PV external source	SAMTEC	CES-102-01-T-S	2-way / 2.54 mm
TP15,TP16	CONNECTOR OUT power output	SAMTEC	CES-102-01-T-S	2-way / 2.54 mm
TP7 to TP14	CONNECTOR EnFilm load board	SAMTEC	CES-108-01-T-S	8-way / 2.54 mm
U1	PRINTED COIL NFC ANTENNA	STMicroelectronics		Width=25.7mm Length=18.5mm #turns = 9
U2	NFC/RFID 4KBIT EEPROM	STMicroelectronics	M24LR04E-RMC6T/2	
U3	EnFilm™ Power Management IC	STMicroelectronics	STBC15AQTR	
U4	EnFilm™ - rechargeable solid state lithium thin film battery	STMicroelectronics	EFL700AF39	700µA.h / 3.9 V With Nickel Foil
PCB	NFC PMB board	CIBEL	SmartPMB v10	FR4, 28x31 mm thickness = 0.7mm

## 7 Revision history

**Table 4. Document revision history**

<b>Date</b>	<b>Revision</b>	<b>Changes</b>
19-Jan-2015	1	Initial release.
20-Aug-2015	2	Updated Figure 1, Figure 2, Figure 3, Figure 4, Figure 6, Figure 8, Figure 9, Figure 10, Figure 11. Updated Section 8: Bill of materials and minor text changes to improve readability.
21-Apr-2016	3	Complete update to add new development information and to improve readability.
04-Jul-2016	4	Updates Introduction.

**IMPORTANT NOTICE – PLEASE READ CAREFULLY**

STMicroelectronics NV and its subsidiaries ("ST") reserve the right to make changes, corrections, enhancements, modifications, and improvements to ST products and/or to this document at any time without notice. Purchasers should obtain the latest relevant information on ST products before placing orders. ST products are sold pursuant to ST's terms and conditions of sale in place at the time of order acknowledgement.

Purchasers are solely responsible for the choice, selection, and use of ST products and ST assumes no liability for application assistance or the design of Purchasers' products.

No license, express or implied, to any intellectual property right is granted by ST herein.

Resale of ST products with provisions different from the information set forth herein shall void any warranty granted by ST for such product.

ST and the ST logo are trademarks of ST. All other product or service names are the property of their respective owners.

Information in this document supersedes and replaces information previously supplied in any prior versions of this document.

© 2016 STMicroelectronics – All rights reserved