



Chipsmall Limited consists of a professional team with an average of over 10 year of expertise in the distribution of electronic components. Based in Hongkong, we have already established firm and mutual-benefit business relationships with customers from,Europe,America and south Asia,supplying obsolete and hard-to-find components to meet their specific needs.

With the principle of “Quality Parts,Customers Priority,Honest Operation,and Considerate Service”,our business mainly focus on the distribution of electronic components. Line cards we deal with include Microchip,ALPS,ROHM,Xilinx,Pulse,ON,Everlight and Freescale. Main products comprise IC,Modules,Potentiometer,IC Socket,Relay,Connector.Our parts cover such applications as commercial,industrial, and automotives areas.

We are looking forward to setting up business relationship with you and hope to provide you with the best service and solution. Let us make a better world for our industry!



## Contact us

Tel: +86-755-8981 8866 Fax: +86-755-8427 6832

Email & Skype: info@chipsmall.com Web: www.chipsmall.com

Address: A1208, Overseas Decoration Building, #122 Zhenhua RD., Futian, Shenzhen, China



# EG1215 SERIES SLIDE SWITCH

ANTI-VANDAL SWITCHES  
 DETECTOR SWITCHES  
 DIP SWITCHES  
 KEYLOCK SWITCHES  
 NAVIGATION SWITCHES  
 PUSHBUTTON SWITCHES  
 ROCKER SWITCHES  
 ROTARY SWITCHES  
**SLIDE SWITCHES**  
 SNAP ACTION SWITCHES  
 TACTILE SWITCHES  
 TOGGLE SWITCHES  
 CAP OPTIONS



## APPLICATIONS / MARKETS



Handheld Devices



Wearable Electronics



Internet of Things



Smart Home



Telecommunication

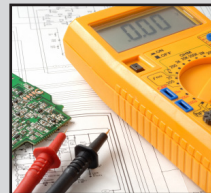

Testing Equipment

**RoHS**

## SPECIFICATIONS

**Contact Rating:** 25mA @ 24VDC  
**Electrical Life:** 10,000 Cycles  
**Contact Resistance:** 70mΩ Max  
**Insulation Resistance:** 1MΩ Min @ 100VDC  
**Dielectric Strength:** 100VAC for 1 Minute  
**Operating Temperature:** -20°C to 70°C  
**Storage Temperature:** -40°C to 85°C  
**Travel:** 1.50mm  
**Contact Arrangement:** SPDT  
**Actuation Force:** 150±100gF

## FEATURES & BENEFITS

- Surface mount PC board design
- 1.50mm travel
- Compact design
- 150 gram force
- SPDT function

## PART NUMBER CONFIGURATOR

Series



EG1215

Actuator  
Option



A - 1.30mm

Function  
Option



A - SPDT

Specifications subject to change without notice 8.2.2018



**E-SWITCH®**

www.e-switch.com

800.867.2717

1

# EG1215 SERIES SLIDE SWITCH

## BODY DIMENSIONS

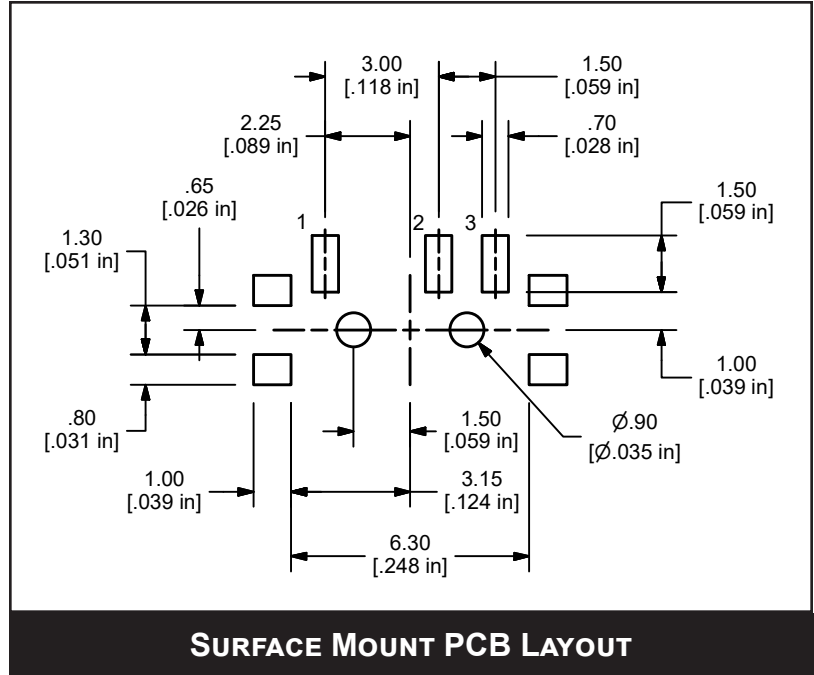
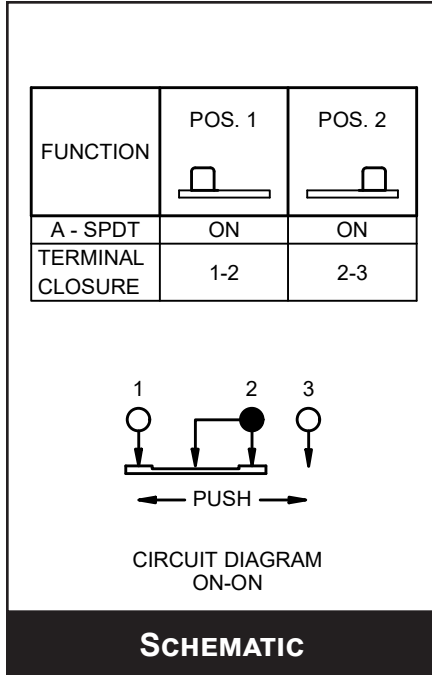

### A - SPDT - FUNCTION OPTION

