



Chipsmall Limited consists of a professional team with an average of over 10 year of expertise in the distribution of electronic components. Based in Hongkong, we have already established firm and mutual-benefit business relationships with customers from,Europe,America and south Asia,supplying obsolete and hard-to-find components to meet their specific needs.

With the principle of “Quality Parts,Customers Priority,Honest Operation,and Considerate Service”,our business mainly focus on the distribution of electronic components. Line cards we deal with include Microchip,ALPS,ROHM,Xilinx,Pulse,ON,Everlight and Freescale. Main products comprise IC,Modules,Potentiometer,IC Socket,Relay,Connector.Our parts cover such applications as commercial,industrial, and automotives areas.

We are looking forward to setting up business relationship with you and hope to provide you with the best service and solution. Let us make a better world for our industry!



## Contact us

Tel: +86-755-8981 8866 Fax: +86-755-8427 6832

Email & Skype: info@chipsmall.com Web: www.chipsmall.com

Address: A1208, Overseas Decoration Building, #122 Zhenhua RD., Futian, Shenzhen, China



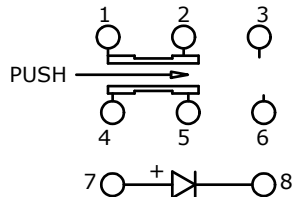
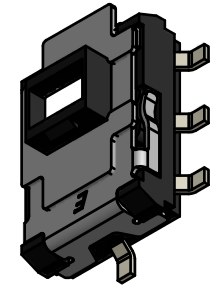
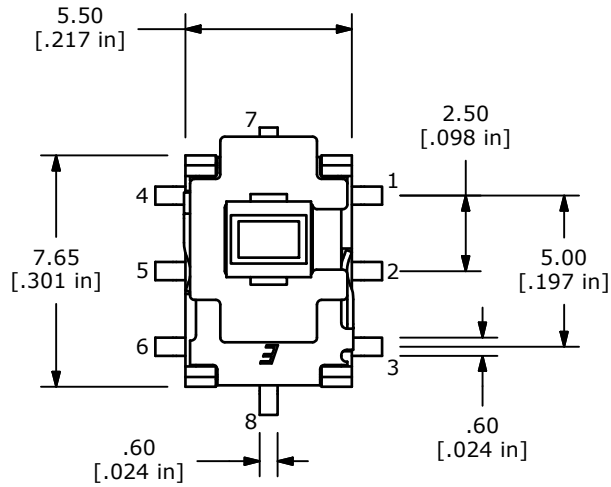
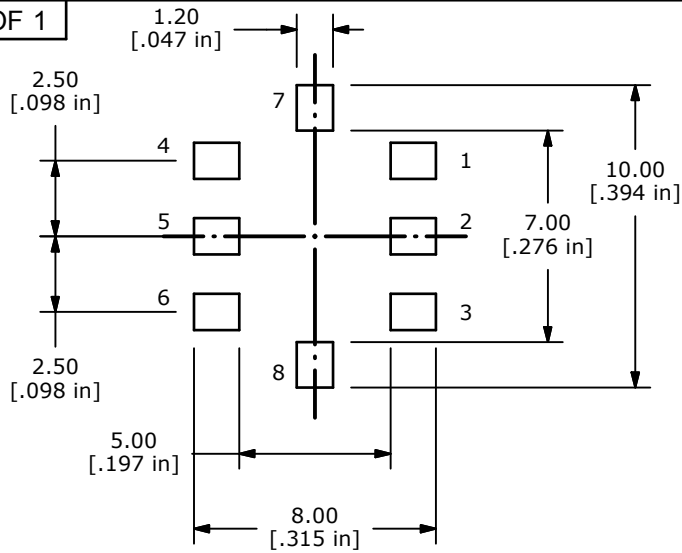

▲ CIRCUIT DIAGRAM ON - ON SINGLE COLOR LED

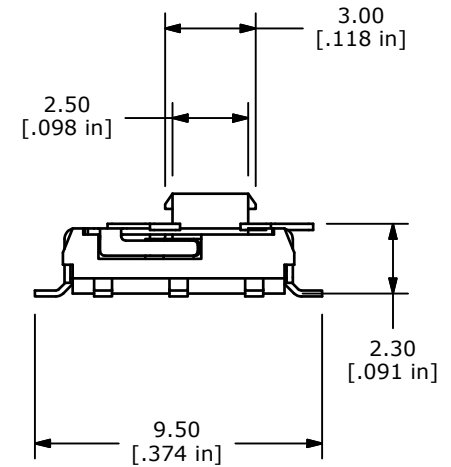
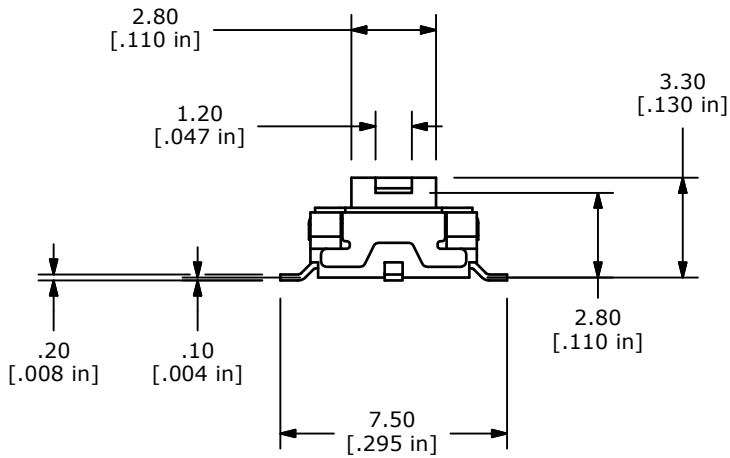

- NOTES:
1. ALL DIMENSIONS IN MM [INCH]
  2. TERMINAL NUMBERS FOR REF. ONLY
  3. TOLERANCE: X.X±0.4  
X.XX±0.25
  4. RATING: 0.3A @ 6VDC
  5. TRAVEL: 2.0 ±0.2
  6. OPERATING FORCE: 200± 150gF
  7. ELECTRICAL LIFE: 10,000 CYCLES MIN.
  8. CONTACT RESISTANCE: 50mΩ MAX.
  9. INSULATION RESISTANCE: 100MΩ AT 500 VDC
  10. DIELECTRIC STRENGTH: 500VAC
  11. OPERATING TEMPERATURE: -40C to +85C
  12. ▲DENOTES CRITICAL PARAMETER
  13. 2002/95/EC (ROHS) COMPLIANT

▲ LED SPECS	UNITS	BLUE
FORWARD CURRENT	mA	20
FORWARD VOLTAGE @ 20mA	V	3.3 typ.-4.0 max.
LUMINOUS INTENSITY @ 20mA	mcd	100 typ.



TITLE EGL2290B

A	22349	New Release	6/10/2016	rc
REV	PCR NO	DESCRIPTION	DATE	BY

SCALE	DATE	DR	DWG	REV
4:1	6/3/2016	rc	B300002	A

THE INFORMATION CONTAINED IN THIS DOCUMENT IS PROPRIETARY TO E-SWITCH AND IS NOT TO BE COPIED OR TRANSFERRED