



Chipsmall Limited consists of a professional team with an average of over 10 year of expertise in the distribution of electronic components. Based in Hongkong, we have already established firm and mutual-benefit business relationships with customers from,Europe,America and south Asia,supplying obsolete and hard-to-find components to meet their specific needs.

With the principle of "Quality Parts,Customers Priority,Honest Operation,and Considerate Service",our business mainly focus on the distribution of electronic components. Line cards we deal with include Microchip,ALPS,ROHM,Xilinx,Pulse,ON,Everlight and Freescale. Main products comprise IC,Modules,Potentiometer,IC Socket,Relay,Connector.Our parts cover such applications as commercial,industrial, and automotives areas.

We are looking forward to setting up business relationship with you and hope to provide you with the best service and solution. Let us make a better world for our industry!



Contact us

Tel: +86-755-8981 8866 Fax: +86-755-8427 6832

Email & Skype: info@chipsmall.com Web: www.chipsmall.com

Address: A1208, Overseas Decoration Building, #122 Zhenhua RD., Futian, Shenzhen, China



THIS COPY IS PROVIDED ON A RESTRICTED BASIS AND IS NOT TO BE USED IN ANY WAY DETRIMENTAL TO THE INTERESTS OF PANDUIT CORP.

WIRE SIZE	NUMBER OF WIRES	NUMBER OF ADDITIONAL WIRES OF ONE SIZE			
		#22 AWG [0,5 mm ²]	#20 AWG [0,75 mm ²]	#18 AWG [1,0 mm ²]	#16 AWG [1,5 mm ²]
#22 AWG [0,5 mm ²]	1	1-4	1-3	1-2	1
	2	1-3	1-2	1-2	1
	3	1-2	1	1	1
	4	1	0	0	0
#20 AWG [0,75 mm ²]	1	1-3	1-3	1-2	1
	2	1-2	1-2	1	1
	3	1	1	0	0
#18 AWG [1,0 mm ²]	1	1-3	1-2	1-2	1
	2	1-2	1	1	0
#16 AWG [1,5 mm ²]	1	1-3	1-2	1	1
#14 AWG [2,5 mm ²]	1	1	1	0	0

NOTES:

1. USED FOR:

- A. SOLID OR STRANDED COPPER WIRE
- B. 221°F [105°C] MAX. OPERATING TEMPERATURE
- C. 600V. MAX. BLDG WIRE (1000 V. MAX. IN SIGNS, FIXTURES & LUMINAIRES)
- D. SEE CHART FOR WIRE COMBINATIONS

2. INSTALLATION TOOLS:

- A. UL LISTED AND CSA CERTIFIED: CT-100A, CT-1550, CT-1551, CT-2400 (CT-2455CH), CT-2500 (CT-2550CH), CT-600-A (CT-550CH)
- B. PANDUIT APPROVED: CT-160, CT-260, CT-400, CT-460

3. WIRE STRIP LENGTH: $7/16" \begin{smallmatrix} +1/32 \\ -0 \end{smallmatrix}$ [11,1 mm $\begin{smallmatrix} +0,8 \\ -0 \end{smallmatrix}$]

4. SEE www.panduit.com FOR PACKAGE QUANTITIES, INDICATED BY PART NUMBER SUFFIX

5. DIMENSIONS IN BRACKETS ARE METRIC EQUIVALENT

6. TWIST ENDS OF STRIPPED WIRE TOGETHER BEFORE INSERTING INTO WIRE JOINT

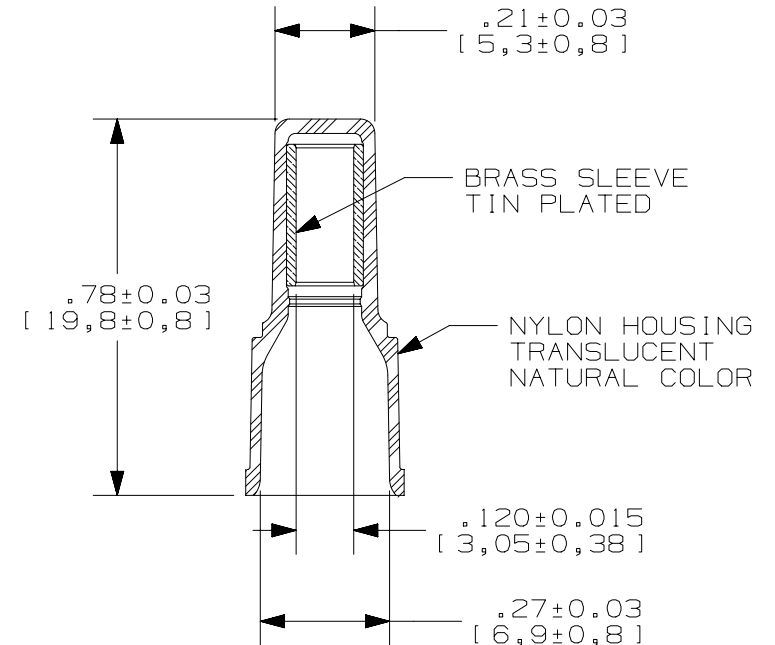

LISTED
587H
E52164



CERTIFIED
LR31212

TITLE STRONGHOLD WIRE JOINT EJN218-216 NYLON INSULATED, #22-14 AWG CUSTOMER DRAWING					
ITEM REVISION NAME 00123STI/00			PANDUIT TM		
DATASET FILE NAME 00123STI.DC/00					
UNLESS OTHERWISE SPECIFIED, DIMENSIONAL TOLERANCES ARE: IN [mm]			MATERIAL: SEE NOTES		
.x ± .1 [2.54]		.xxx ± .005 [.127]		DRAWING NUMBER: SH41342	
.xx ± .03 [.76]		ANGLES ± 5 °		THIRD ANGLE PROJECTION	
DRAWN BY DAW	DATE -	CHK	SCALE N.T.S.	SHEET 1 OF 1	
REV			DESCRIPTION		SIZE A

00	2/18	JHNU	TMR	RGB	RELEASED	00123SH
REV	DATE	BY	CHK	APR	DESCRIPTION	ECN

D10100DA/12