



Chipsmall Limited consists of a professional team with an average of over 10 year of expertise in the distribution of electronic components. Based in Hongkong, we have already established firm and mutual-benefit business relationships with customers from,Europe,America and south Asia,supplying obsolete and hard-to-find components to meet their specific needs.

With the principle of “Quality Parts,Customers Priority,Honest Operation,and Considerate Service”,our business mainly focus on the distribution of electronic components. Line cards we deal with include Microchip,ALPS,ROHM,Xilinx,Pulse,ON,Everlight and Freescale. Main products comprise IC,Modules,Potentiometer,IC Socket,Relay,Connector.Our parts cover such applications as commercial,industrial, and automotives areas.

We are looking forward to setting up business relationship with you and hope to provide you with the best service and solution. Let us make a better world for our industry!



Contact us

Tel: +86-755-8981 8866 Fax: +86-755-8427 6832

Email & Skype: info@chipsmall.com Web: www.chipsmall.com

Address: A1208, Overseas Decoration Building, #122 Zhenhua RD., Futian, Shenzhen, China



PE22100 Evaluation Kit (EVK) User's Manual

UltraCMOS® Isolated Transformer Driver



Copyright and Trademarks

©2017, Peregrine Semiconductor Corporation. All rights reserved. The Peregrine name, logo, UTSi and UltraCMOS are registered trademarks and HaRP, MultiSwitch and DuNE are trademarks of Peregrine Semiconductor Corp. All other trademarks mentioned herein are the property of their respective owners.

Disclaimers

The information in this document is believed to be reliable. However, Peregrine assumes no liability for the use of this information. Use shall be entirely at the user's own risk. No patent rights or licenses to any circuits described in this document are implied or granted to any third party. Peregrine's products are not designed or intended for use in devices or systems intended for surgical implant, or in other applications intended to support or sustain life, or in any application in which the failure of the Peregrine product could create a situation in which personal injury or death might occur. Peregrine assumes no liability for damages, including consequential or incidental damages, arising out of the use of its products in such applications.

Patent Statement

Peregrine products are protected under one or more of the following U.S. patents: patents.psemi.com

Sales Contact

For additional information, contact Sales at sales@psemi.com.

Corporate Headquarters

9369 Carroll Park Drive, San Diego, CA, 92121
858-731-9400

Table of Contents

Introduction - - - - -	1
Introduction - - - - -	1
Application Support	1
Evaluation Kit Contents and Requirements	1
Kit Contents	1
Hardware Requirements	2
Safety Precautions	2
Evaluation Board Assembly - - - - -	3
Evaluation Board Assembly Overview - - - - -	3
Block Diagram and Schematic	4
Circuit Description	5
Quick Start Guide - - - - -	7
Quick Start Overview - - - - -	7
Evaluation Board Overview	7
Evaluation Test Setup	8
Hardware Operation	9
Technical Resources - - - - -	11
Technical Resources - - - - -	11

This page intentionally left blank.



Introduction

Introduction

The PE22100 is a push pull driver for driving small transformers for isolated power supply applications. The PE22100 drives the primary of a center-tapped transformer such as the 782100 family from Murata from a 3.0V or a 5V supply to deliver an isolated power supply.

The device consists of an on-chip oscillator whose frequency is set by an external capacitor. The oscillator output is divided by two in frequency to create anti-phase clock signals that drive two power switches. The device also contains an internal current limit and thermal cutout. The PE22100 is available in a 2 x 2 x 0.5 mm QFN package and is specified for operation from -40° to +125°C.

The PE22100 evaluation board allows the user to evaluate the PE22100 transformer driver IC in a typical operating circuit.

The PE22100 is an isolated transformer driver capable of providing up to 1W of isolated power via an external transformer.

The PE22100 evaluation kit (EVK) user's manual includes the evaluation board schematic, circuit description, quick start guide, and measurement results.

Application Support

For any technical inquiries regarding the evaluation kit or software, please visit applications support at www.psemi.com (fastest response) or call (858) 731-9400.

Evaluation Kit Contents and Requirements

Kit Contents

The PE22100 EVK includes the following hardware required to evaluate the transformer driver.

Table 1 • PE22100 Evaluation Kit Contents

Quantity	Description
1	PE22100 transformer driver evaluation board assembly (PRT-66476)

Hardware Requirements

In order to evaluate the performance of the evaluation board, the following equipment is required:

- 5V DC power supply
- Digital voltmeter
- Test leads

Safety Precautions



Caution: The PE22100 transformer driver EVK contains components that might be damaged by exposure to voltages in excess of the specified voltage, including voltages produced by electrostatic discharges. Handle the board in accordance with procedures for handling static-sensitive components. Avoid applying excessive voltages to the power supply terminals or signal inputs or outputs.



Caution: PCB surface can become hot. Contact may cause burns do not touch!

Evaluation Board Assembly

2

Evaluation Board Assembly Overview

The evaluation board (EVB) is assembled with a PE22100 transformer driver and a Murata 782100/55JVC transformer. The device is intended to be evaluated using the test pins shown in **Figure 1**.

Figure 1 • PE22100 Evaluation Board Assembly

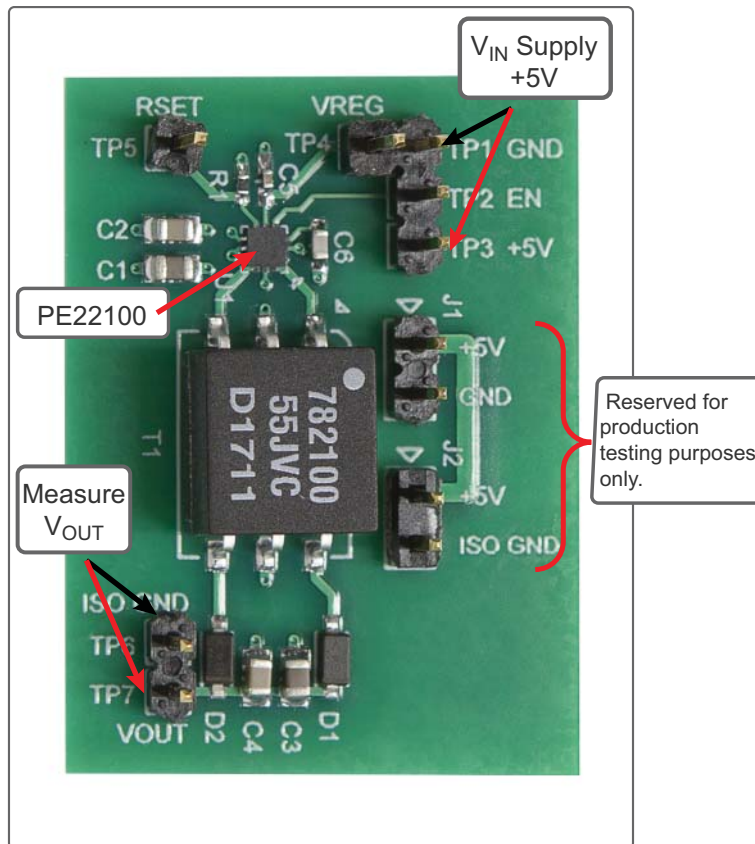

Block Diagram and Schematic

The evaluation board block diagram and schematic are shown in **Figure 2** and **Figure 3**.

Figure 2 • PE22100 Evaluation Board Block Diagram

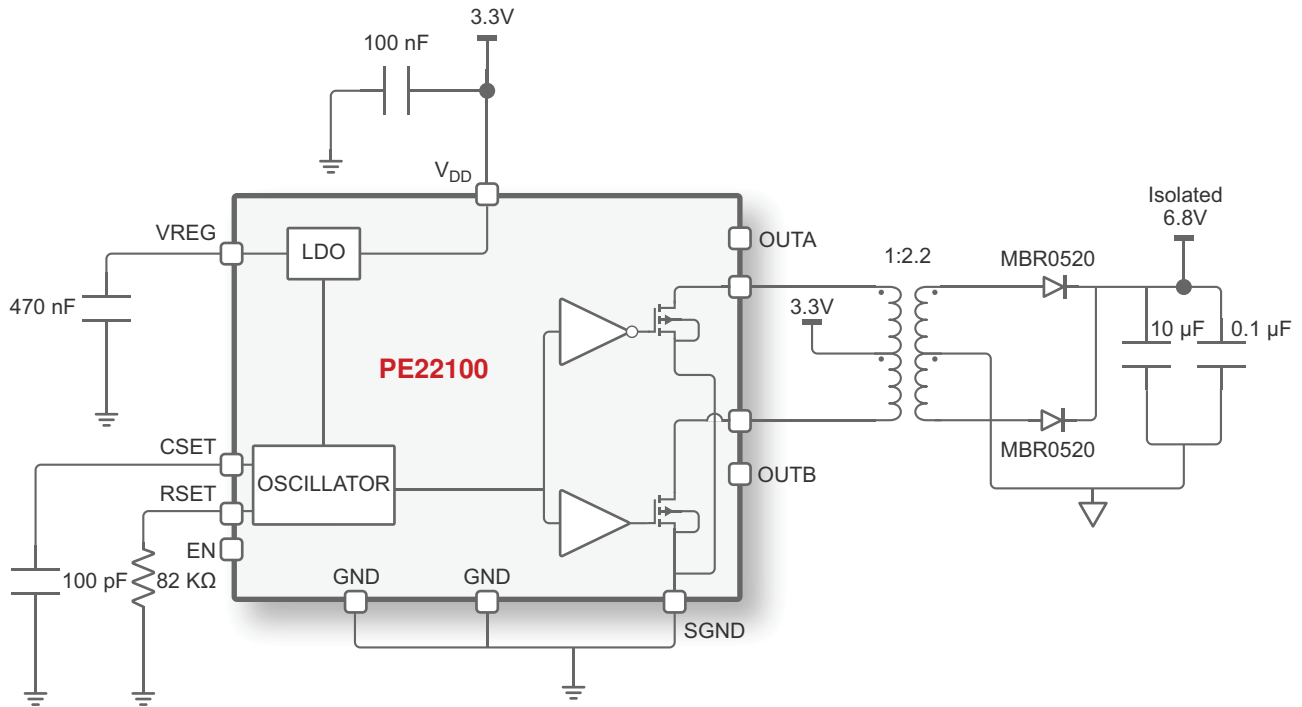
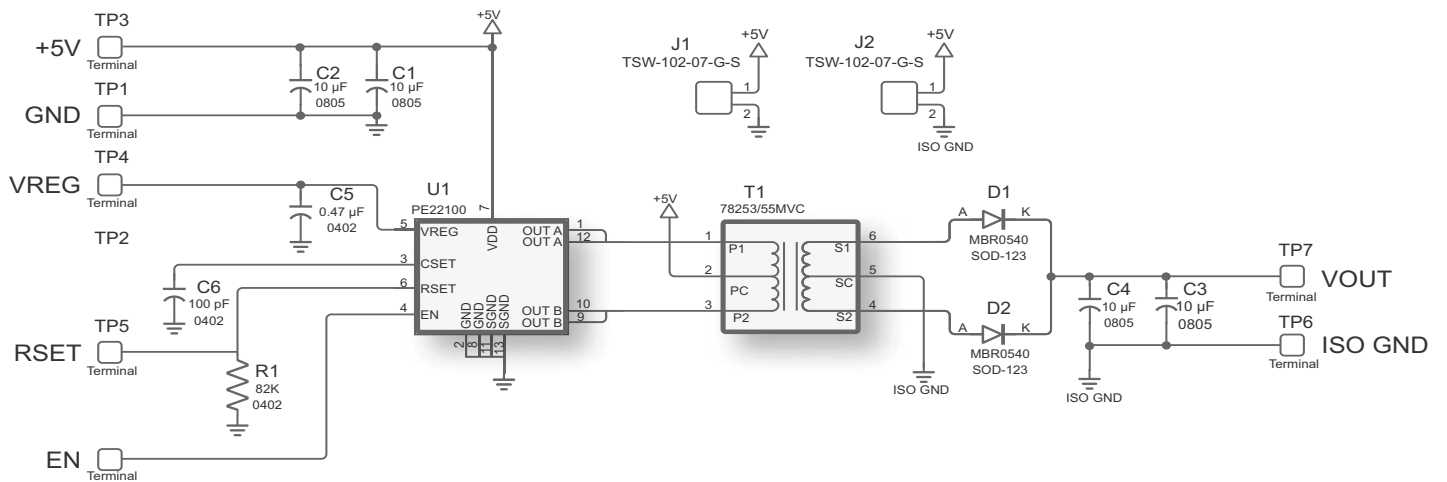

Figure 3 • PE22100 Evaluation Board Schematic



Circuit Description

The evaluation board is configured with a PE22100 transformer driver (U1) and a 782100/55JVC transformer (T1) in a push-pull configuration. The output from this transformer is then rectified via D1 and D2 to produce an isolated DC output.

The PE22100 features an internal regulator that supplies the chip will output a nominal 2.6V on C5.

An internal oscillator is generated in the chip and is visible as a triangle wave on C6.

This page intentionally left blank.

Quick Start Guide



Quick Start Overview

This chapter will guide the user through the operating specifications, hardware configuration, and test setup. Operating the EVB beyond the operating specifications can result in damage to the high-speed driver and/or the transformer driver.

Evaluation Board Overview

The evaluation board is designed to ease customer evaluation of Peregrine’s products. The board contains:

- Header pins for power inputs and outputs
- Test points for performance verification

The operating specifications of the evaluation board are:

- Maximum input operating voltage of 5.5V
- Minimum input operating voltage of 4.5V
- Maximum output current of 200 mA

Figure 4 shows the typical efficiency and output voltage using the 782100/55JVC transformer. The efficiency is measured using the output voltage at TP6 and TP7, and includes the losses due to the rectifier diodes.

Figure 4 • Efficiency and Output Voltage, $C_{SET} = 100\text{ pF}$

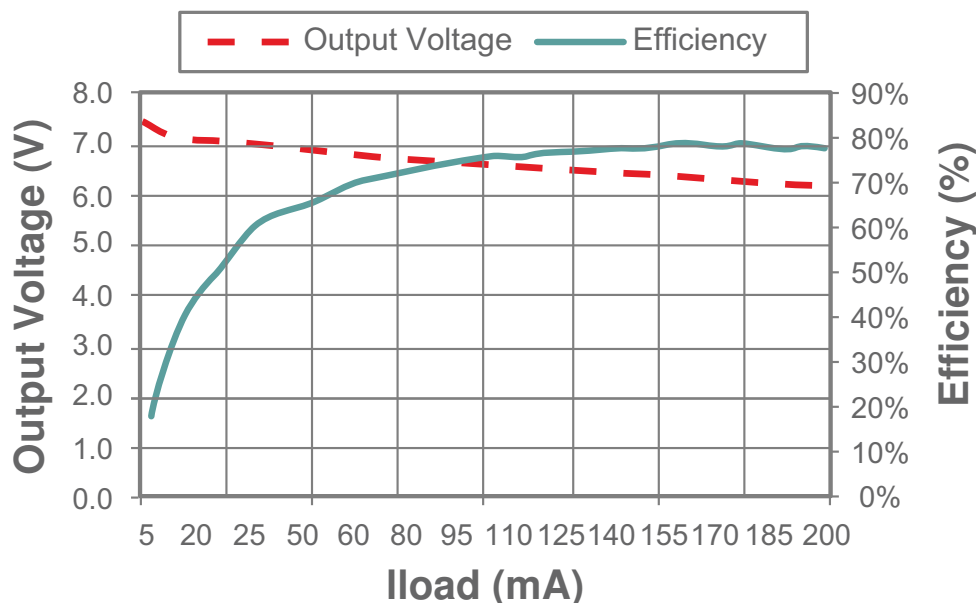

Evaluation Test Setup

Figure 5 shows the test setup for the PE22100 evaluation board. Make sure that the specified safety precautions mentioned in “Safety Precautions” on page 2 are followed.

Figure 5 • PE22100 Evaluation Board Test Setup

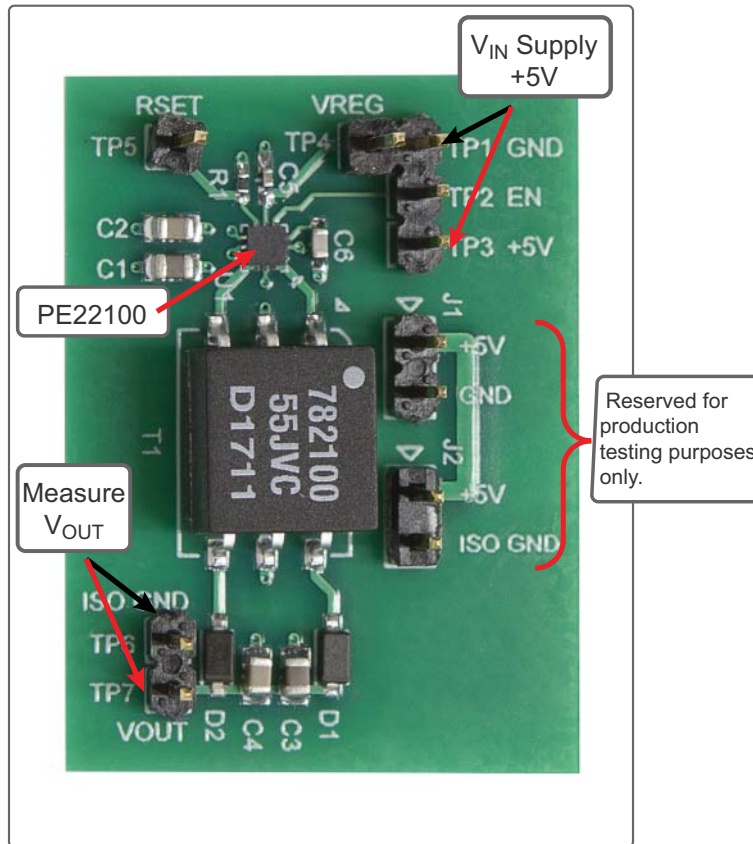

Hardware Operation

The general guidelines for operating the hardware evaluation board are listed in this section. Follow the steps to configure the hardware properly for the performance.

- 1) Verify that all DC power supplies are turned off before proceeding.
- 2) Connect 5V to TP3 and ground return to TP1.
- 3) Measure the output supply with a voltmeter connected across TP6 and TP7.

This page intentionally left blank.

Technical Resources



Technical Resources

Additional technical resources are available for download in the Products section at www.psemi.com. These include the Product Specification datasheet, evaluation kit schematic and bill of materials, material declaration form, and PC-compatible software file.

Trademarks are subject to trademark claims.

This page intentionally left blank.