



Chipsmall Limited consists of a professional team with an average of over 10 year of expertise in the distribution of electronic components. Based in Hongkong, we have already established firm and mutual-benefit business relationships with customers from,Europe,America and south Asia,supplying obsolete and hard-to-find components to meet their specific needs.

With the principle of “Quality Parts,Customers Priority,Honest Operation,and Considerate Service”,our business mainly focus on the distribution of electronic components. Line cards we deal with include Microchip,ALPS,ROHM,Xilinx,Pulse,ON,Everlight and Freescale. Main products comprise IC,Modules,Potentiometer,IC Socket,Relay,Connector.Our parts cover such applications as commercial,industrial, and automotives areas.

We are looking forward to setting up business relationship with you and hope to provide you with the best service and solution. Let us make a better world for our industry!



Contact us

Tel: +86-755-8981 8866 Fax: +86-755-8427 6832

Email & Skype: info@chipsmall.com Web: www.chipsmall.com

Address: A1208, Overseas Decoration Building, #122 Zhenhua RD., Futian, Shenzhen, China



Evaluation Kit

APPLICABLE PARTS (SOLD SEPARATELY)

- PA97

INTRODUCTION

This easy-to-use kit provides a platform for the evaluation of linear power amplifiers circuits using the PA97 pin-out. With ample breadboarding areas it is flexible enough to analyze a multitude of standard or proprietary circuit configurations. Critical connections for power supply bypassing are pre-wired. Components not usually readily available in engineering labs are provided. External connection to the evaluation kit can be made via the terminals at the edge of the circuit board. These terminal pads are suitable for standard banana jacks or direct soldering of wires. The schematic is shown in Figure 2.

Figure 1: PCB

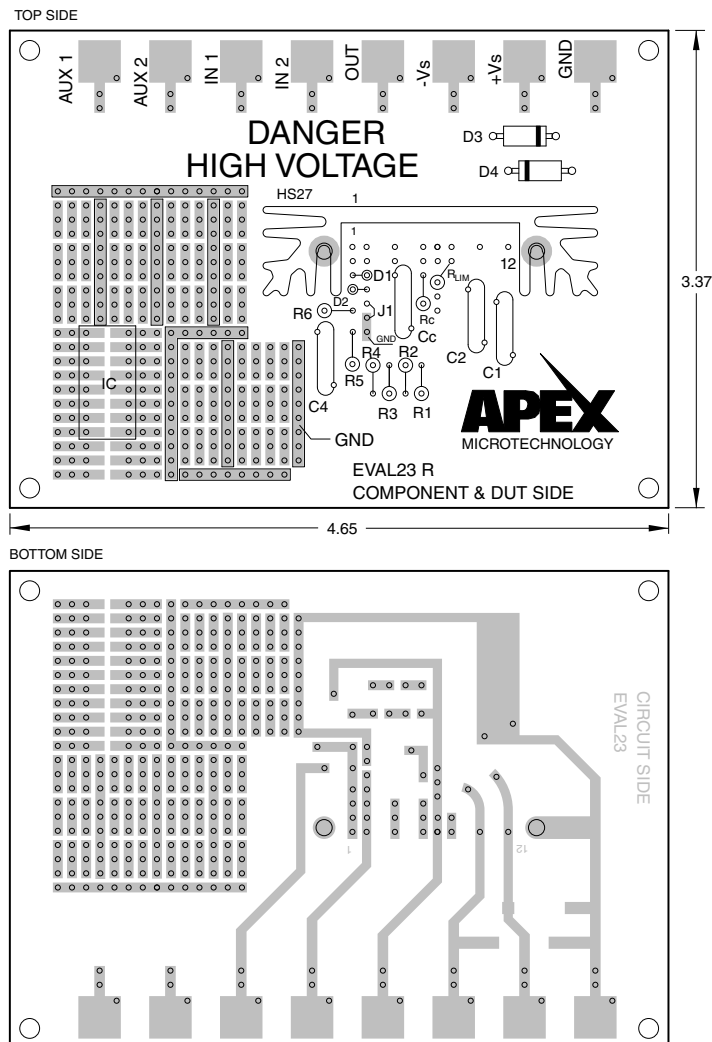

Figure 2: EK Schematic

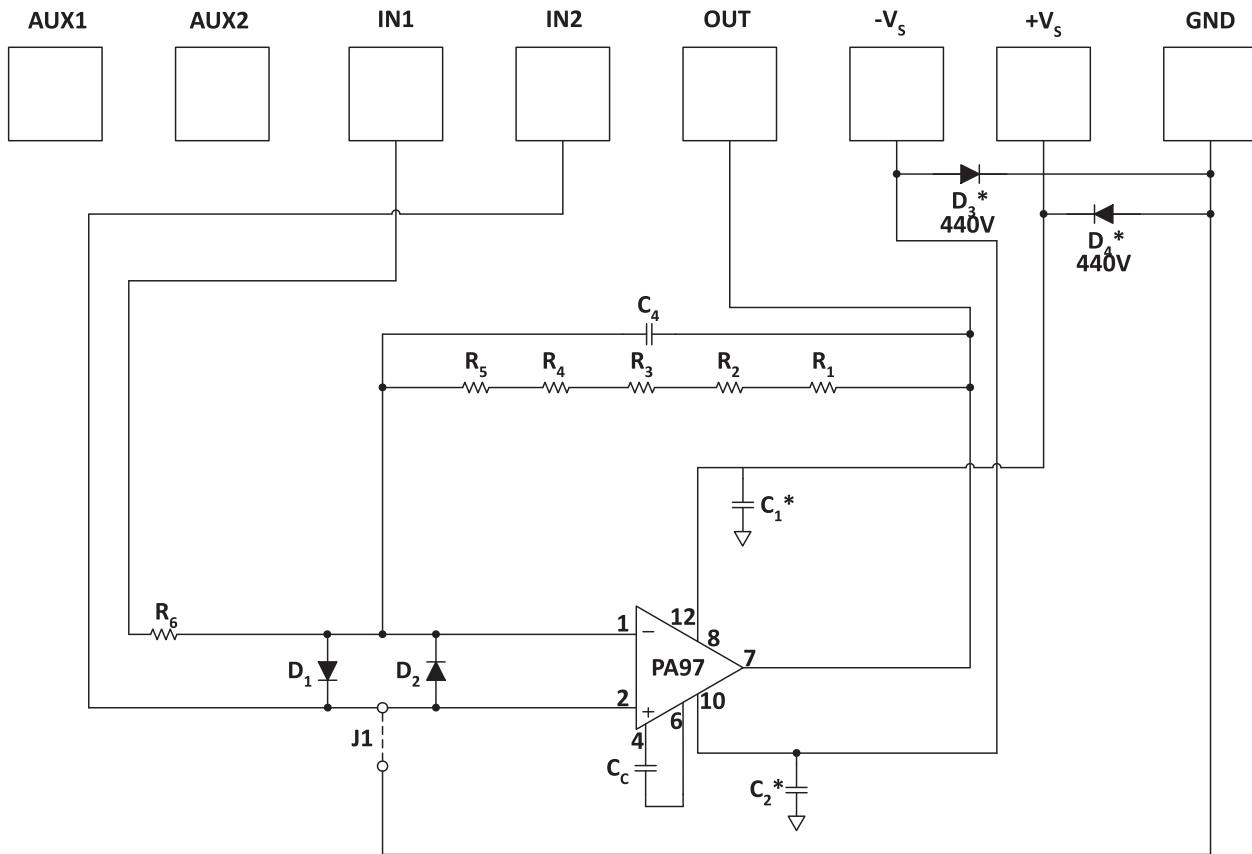

Figure 2 shows the schematic of the evaluation kit's pre-wired connections. Components supplied with the kit are marked with an asterisk (*). See the amplifier's data sheet for full application information.

PARTS LIST

Reference	Manufacturer Part #	Description	QTY
	EVAL23	PC Board	1
D3, D4	P6KE440A	TransZorb, General	2
C1, C2	562R5GAS10	Capacitor 0.01μF 1kV	2

ASSEMBLY

1. See Figure 2. Insert and solder the TransZorb diodes at D3 and D4 (440V).
2. Insert and solder the disc bypass capacitors at C1 and C2.
3. Jumper R_{LIM} and R_C . Note that heatsink HS28 is not used.
4. Add banana jacks as necessary to complete connections to external circuits and power supplies.
5. Insert the amplifier into the PCB mounting holes located in the space between the heatsink fins (not used) and solder pins.
6. Add other passive components as necessary to complete your circuit.
7. Most common configurations will ground the non-inverting pin of the amplifier. J1 is a convenient way to do this if necessary for your application circuit.
8. The four holes at the corners of the circuit board are for mounting #6 standoff spacers if desired.
9. R1-R5 are multiple feedback resistors in series. Commonly available resistors do not have a breakdown voltage sufficient to stand off the output voltage of the amplifier. Using multiple resistors will divide down the voltage that each resistor must withstand.

NEED TECHNICAL HELP? CONTACT APEX SUPPORT!

For all Apex Microtechnology product questions and inquiries, call toll free 800-546-2739 in North America. For inquiries via email, please contact apex.support@apexanalog.com. International customers can also request support by contacting their local Apex Microtechnology Sales Representative. To find the one nearest to you, go to www.apexanalog.com

IMPORTANT NOTICE

Apex Microtechnology, Inc. has made every effort to insure the accuracy of the content contained in this document. However, the information is subject to change without notice and is provided "AS IS" without warranty of any kind (expressed or implied). Apex Microtechnology reserves the right to make changes without further notice to any specifications or products mentioned herein to improve reliability. This document is the property of Apex Microtechnology and by furnishing this information, Apex Microtechnology grants no license, expressed or implied under any patents, mask work rights, copyrights, trademarks, trade secrets or other intellectual property rights. Apex Microtechnology owns the copyrights associated with the information contained herein and gives consent for copies to be made of the information only for use within your organization with respect to Apex Microtechnology integrated circuits or other products of Apex Microtechnology. This consent does not extend to other copying such as copying for general distribution, advertising or promotional purposes, or for creating any work for resale.

APEX MICROTECHNOLOGY PRODUCTS ARE NOT DESIGNED, AUTHORIZED OR WARRANTED TO BE SUITABLE FOR USE IN PRODUCTS USED FOR LIFE SUPPORT, AUTOMOTIVE SAFETY, SECURITY DEVICES, OR OTHER CRITICAL APPLICATIONS. PRODUCTS IN SUCH APPLICATIONS ARE UNDERSTOOD TO BE FULLY AT THE CUSTOMER OR THE CUSTOMER'S RISK.

Apex Microtechnology, Apex and Apex Precision Power are trademarks of Apex Microtechnology, Inc. All other corporate names noted herein may be trademarks of their respective holders.