



Chipsmall Limited consists of a professional team with an average of over 10 year of expertise in the distribution of electronic components. Based in Hongkong, we have already established firm and mutual-benefit business relationships with customers from,Europe,America and south Asia,supplying obsolete and hard-to-find components to meet their specific needs.

With the principle of “Quality Parts,Customers Priority,Honest Operation,and Considerate Service”,our business mainly focus on the distribution of electronic components. Line cards we deal with include Microchip,ALPS,ROHM,Xilinx,Pulse,ON,Everlight and Freescale. Main products comprise IC,Modules,Potentiometer,IC Socket,Relay,Connector.Our parts cover such applications as commercial,industrial, and automotives areas.

We are looking forward to setting up business relationship with you and hope to provide you with the best service and solution. Let us make a better world for our industry!



## Contact us

Tel: +86-755-8981 8866 Fax: +86-755-8427 6832

Email & Skype: info@chipsmall.com Web: www.chipsmall.com

Address: A1208, Overseas Decoration Building, #122 Zhenhua RD., Futian, Shenzhen, China



**Evaluation Kit**

**APPLICABLE PARTS (SOLD SEPARATELY)**

- PA75CX

**INTRODUCTION**

Fast, easy breadboarding of circuits using the PA75CX is possible with the EK33 PC board. Mounting holes are provided and the provision for standard banana jacks simplifies connection and testing. Components are labeled on both sides of the board for ease in probing. This kit is not suitable for PA75CC or PA75CD.

A multitude of circuit configurations are possible; therefore, some components may be omitted depending on the desired circuit.

**Figure 1: PCB Layout**

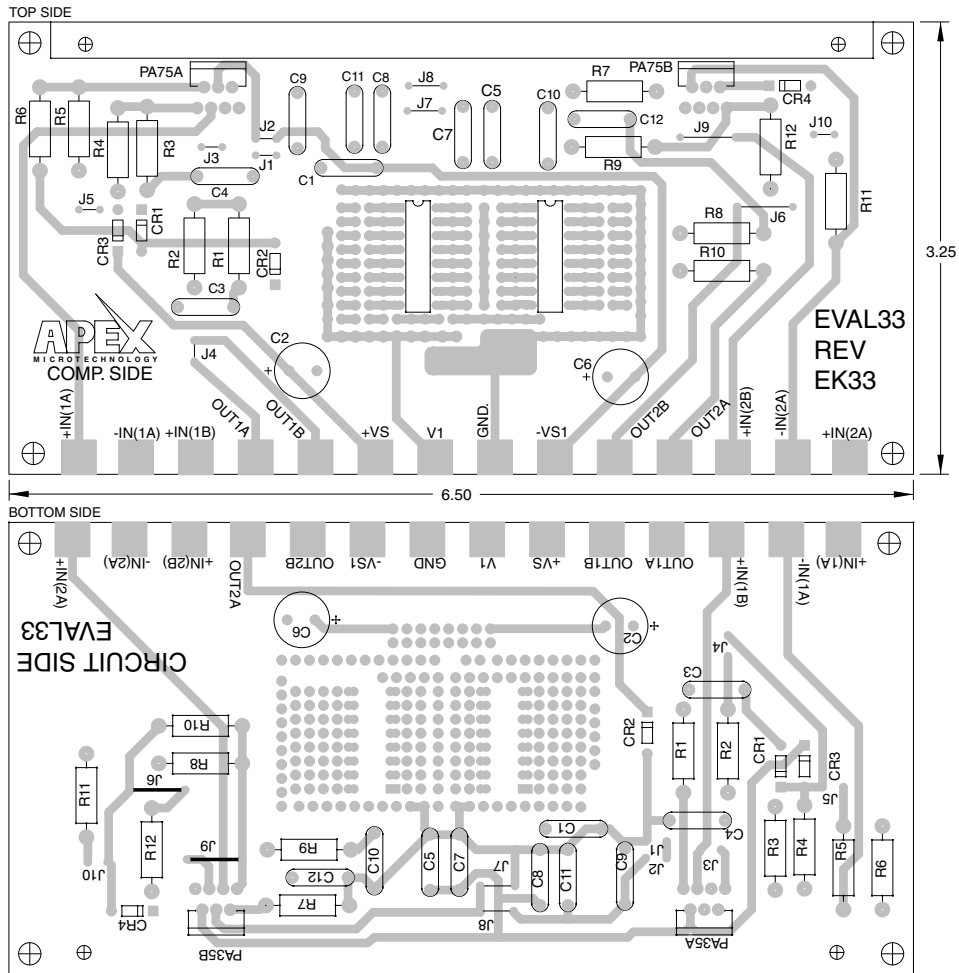
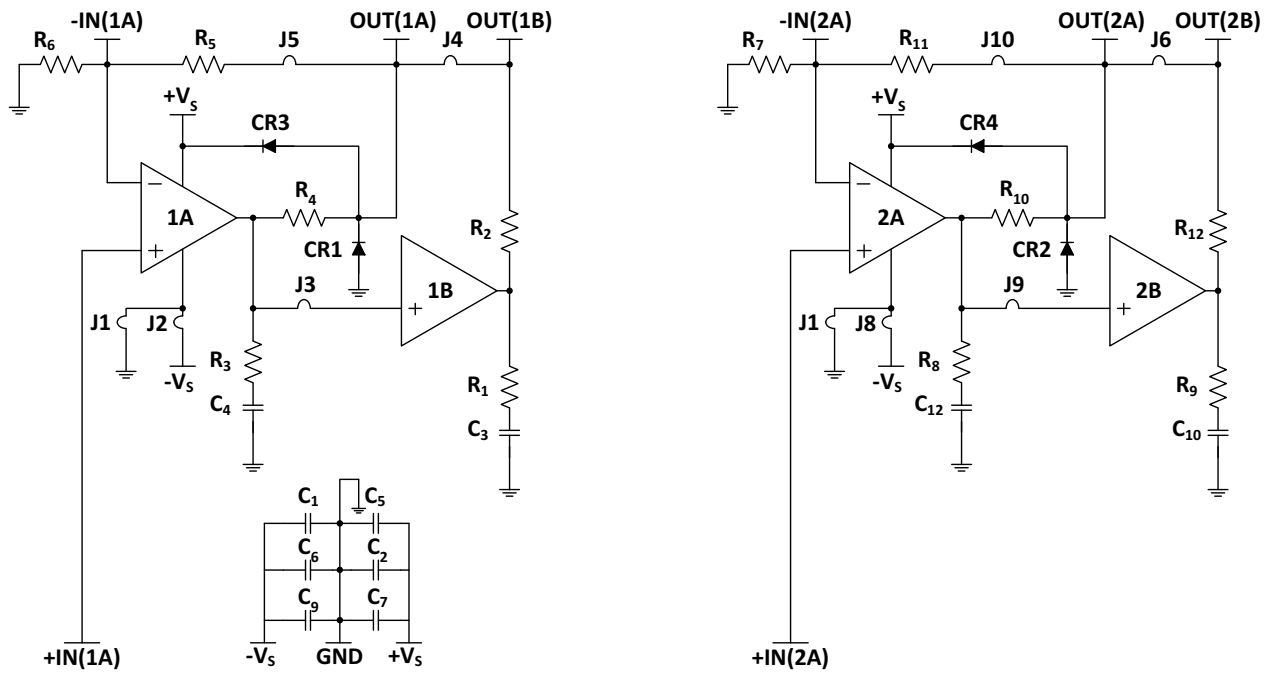

Figure 2: Equivalent Schematic



**TYPICAL COMPONENT FUNCTIONS**

Component	Function
C1, C2, C5, C6, C7, C9	Power Supply bypasses MUST be used for each amplifier. Usually ceramic types of .01μF to 1.0μF, as well as, 10μF of capacitance per ampere of output current.
R11, R5	Feedback resistors
The following locations should be jumpered unless used otherwise (their most common function is listed).	
J3, J9	Output amp a to input amp b
J2, J8	-Vs
J4, J6	Connects paralleling output a to output b
J5, J10	Connects feedback for amp a
The following locations should be left open unless used otherwise (their most common anticipated function is listed)	
J1, J7	Connects -Vs to ground reference

The function of all other components is up to the designer’s circuit needs.

**PARTS LIST**

Reference	Manufacturer Part #	Description	QTY
	EVAL33	Evaluation Board	1
	CLAMP04	Clamp for HS29	2
	MS11	Pin Receptacle, 30 pin strip	1
	TW14	Thermal Washer TO-220 (10/Pack)	1
	HS29	Heat Sink, 2.7°C/W	1

**Figure 3: Assembly**

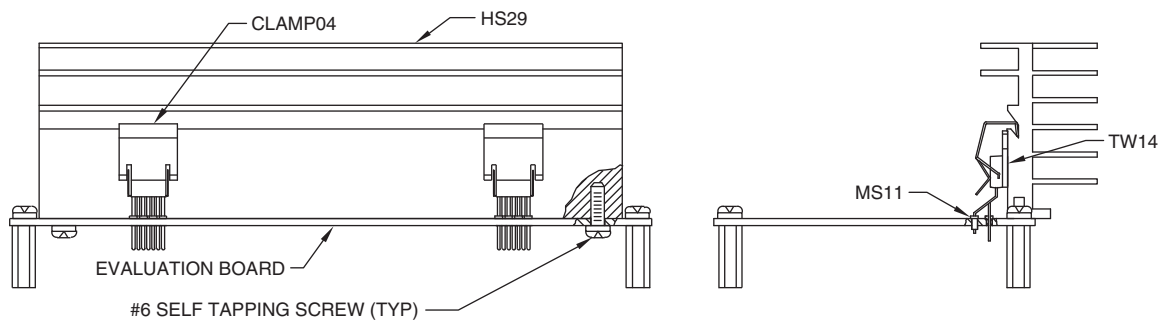

**NEED TECHNICAL HELP? CONTACT APEX SUPPORT!**

For all Apex Microtechnology product questions and inquiries, call toll free 800-546-2739 in North America. For inquiries via email, please contact [apex.support@apexanalog.com](mailto:apex.support@apexanalog.com). International customers can also request support by contacting their local Apex Microtechnology Sales Representative. To find the one nearest to you, go to [www.apexanalog.com](http://www.apexanalog.com)

**IMPORTANT NOTICE**

Apex Microtechnology, Inc. has made every effort to insure the accuracy of the content contained in this document. However, the information is subject to change without notice and is provided "AS IS" without warranty of any kind (expressed or implied). Apex Microtechnology reserves the right to make changes without further notice to any specifications or products mentioned herein to improve reliability. This document is the property of Apex Microtechnology and by furnishing this information, Apex Microtechnology grants no license, expressed or implied under any patents, mask work rights, copyrights, trademarks, trade secrets or other intellectual property rights. Apex Microtechnology owns the copyrights associated with the information contained herein and gives consent for copies to be made of the information only for use within your organization with respect to Apex Microtechnology integrated circuits or other products of Apex Microtechnology. This consent does not extend to other copying such as copying for general distribution, advertising or promotional purposes, or for creating any work for resale.

APEX MICROTECHNOLOGY PRODUCTS ARE NOT DESIGNED, AUTHORIZED OR WARRANTED TO BE SUITABLE FOR USE IN PRODUCTS USED FOR LIFE SUPPORT, AUTOMOTIVE SAFETY, SECURITY DEVICES, OR OTHER CRITICAL APPLICATIONS. PRODUCTS IN SUCH APPLICATIONS ARE UNDERSTOOD TO BE FULLY AT THE CUSTOMER OR THE CUSTOMER'S RISK.

Apex Microtechnology, Apex and Apex Precision Power are trademarks of Apex Microtechnology, Inc. All other corporate names noted herein may be trademarks of their respective holders.