



Chipsmall Limited consists of a professional team with an average of over 10 year of expertise in the distribution of electronic components. Based in Hongkong, we have already established firm and mutual-benefit business relationships with customers from,Europe,America and south Asia,supplying obsolete and hard-to-find components to meet their specific needs.

With the principle of "Quality Parts,Customers Priority,Honest Operation,and Considerate Service",our business mainly focus on the distribution of electronic components. Line cards we deal with include Microchip,ALPS,ROHM,Xilinx,Pulse,ON,Everlight and Freescale. Main products comprise IC,Modules,Potentiometer,IC Socket,Relay,Connector.Our parts cover such applications as commercial,industrial, and automotives areas.

We are looking forward to setting up business relationship with you and hope to provide you with the best service and solution. Let us make a better world for our industry!



Contact us

Tel: +86-755-8981 8866 Fax: +86-755-8427 6832

Email & Skype: info@chipsmall.com Web: www.chipsmall.com

Address: A1208, Overseas Decoration Building, #122 Zhenhua RD., Futian, Shenzhen, China



Evaluation Kit for MP103 Power Amplifier

APPLICABLE PARTS (SOLD SEPARATELY)

- MP103

INTRODUCTION

This easy to use kit provides a platform with good circuit board layout and grounding to evaluate MP103 Power Amplifier. With additional prototype area, it is flexible enough to analyze a multitude of standard or proprietary circuit configurations. All necessary components are provided with the kit. External connections to the evaluation kit can be made through the connectors at the edges of the circuit. The circuit provides a line termination of 50Ω.

Figure 1: Equivalent Schematic

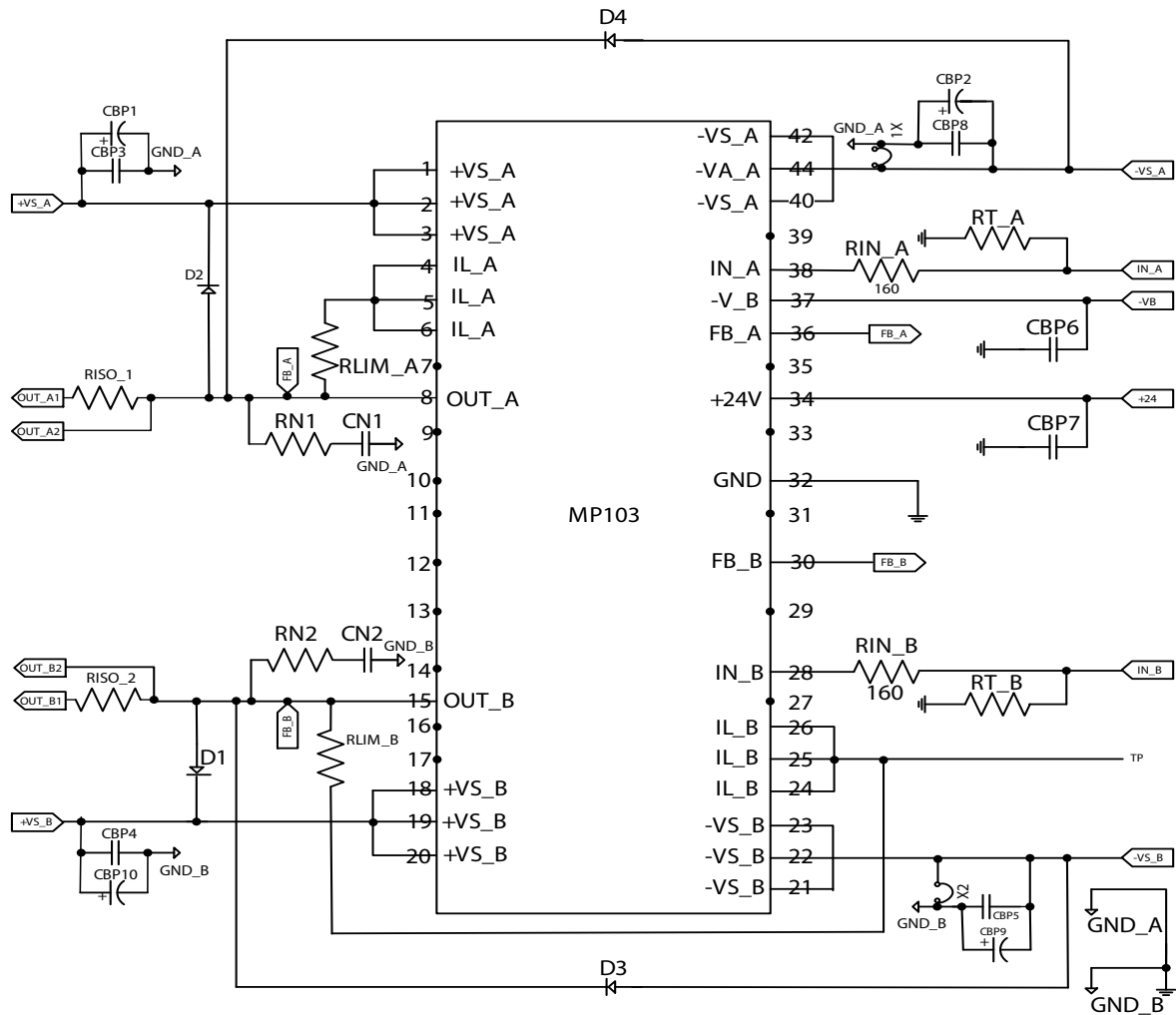

PARTS LIST

RESISTORS

Ref	Apex Part #	Description	Qty
RINA, RINB	CFR-50JB-52-160R	160Ω, ½W	2
RTA, RTB	PR03000205109JAC00	51Ω, 3W, 5%	2
RN1, RN2	CMF5510K000FKEA	10kΩ, 1/4W, 1%	2
RLIMA, RLIMB	15FR100E-ND	0.1Ω, 5W, Metal	2
RISO1, RISO2	ERX-5SJ1R5	1.5 Ω, 5W, Metal Film	2

PRINTED CIRCUIT BOARD

Ref	Apex Part #	Description	Qty
EVAL 85	EVAL85	PRINTED CIRCUIT BOARD	1

CAPACITORS

Designator	Manufacturer Pin	Description	Qty
CN1, CN2	RDER72E472K1M1H03A	Ceramic, 4.7nF, 200V	2
CBP1, CBP10	LGU2D221MELY	Alum, 220uF, 200V	2
CBP2, CBP9	EEU-FM1H681L	ALUM, 680uF, 50V	2
CBP3, CBP4	C5750X7R2E105K230KA	Film, 1uf, 250V	2
CBP5, CBP6	C5750X7R2E105K230KA	Film, 1uf, 250V	2
CBP7, CBP8	C5750X7R2E105K230KA	Film, 1uf, 250V	2

DIODES

Ref	Apex Part #	Description	Qty
D1, D2, D3, D4	MUR160RLG	Rectifier, Ultra-fast	4

HARDWARE

Description	Apex Part #	Qty
HEAT SINK FOR AMPLIFIER	HS31	1
CAGE JACKS	MS11	42
BNC CONNECTOR, PC MOUNT	146510CJ	2
BANANA JACKS, PC MOUNT	571-0100	17
SCREW, PANHEAD, #8 X 0.375"	91735A192	4
SPACER GROMMETS	60SPG00004	4
STANDOFF, HEX, #8 X 2.00"	2221	4
Screw Pan head, #8 x 0.625"	92325A313	4
Screw, Pan head, #4 x 0.625"	90272A105	4

MISCELLANEOUS

Designator	Manufacturer Pin	Qty
JUMPER, SLIP ON	SPC02SVJN-RC	10
HEADER, CONNECTOR	PRPC002SADN-RC	10
TEST POINT, PC MINI	5001	10

BEFORE YOU GET STARTED

- All Apex Microtechnology amplifiers should be handled using proper ESD precautions.
- Always use the heat sink and thermal washers included in this kit.
- Always use adequate power supply bypassing.
- Do not change the connections while the circuit is powered.
- Initially set all power supplies to the minimum operations levels allowed in the device data sheet.
- Check for oscillations.
- Please refer to Application Note, AN01 for general operating conditions.

ASSEMBLY INSTRUCTIONS

During the assembly, please refer to the circuit schematics, assembly drawings, and the data sheet of the part being used on the evaluation kit.

1. Note that each side of the circuit board is identified as either the component side or the DUT side. The component side has the designators printed on that side.
2. All through hole components (except the cage jacks) are installed on the component side of the board and soldered on the DUT side.
3. 42 pin receptacles are supplied with this evaluation kit. Insert the carrier strip through the DUT side, and solder the cage jacks on the component side. Once the cage jacks are soldered, remove the carrier strip, leaving only cage jacks soldered on the board.
4. Install CBP3, CBP4, CBP5, CBP6, CBP7 and CBP8 on the component side of the board.
5. Install diodes, D1, D2, D3, D4 and capacitors CBP1, CBP10 on the component side of the board. Ensure that the orientation of the components match the circuit schematic drawing.
6. Next install all the smaller components on the board. This is done because it becomes difficult to install a smaller part on the board once all the larger components are installed.

7. Mount the BNC connector provided with the kit (146510CJ) and solder it to the board. Also mount the banana jacks on the board. Install other miscellaneous components like jumpers and test points to complete your application circuit.
8. From the DUT side of the PCB, snap the spacer-grommets into the holes at the four corners of the PCB. Notice that the holes are slightly rectangular and match the spacer-grommets long and short sides to the holes in the PCB.
9. Apply a thin, uniform layer of thermal grease to the amplifier; a straight edge may be useful here. Position the amplifier over the mounting holes in the heat sink. Firmly push the amplifier onto the heat sink while slightly rotating the amplifier back and forth, ending with the mounting holes of the amplifier over the mounting holes in the heat sink.
10. Use 4-40x $\frac{1}{4}$ " machine screws to mount the amplifier to the heat sink. Do not over-tighten the screws as this provides no thermal benefit and may break the hardware.
11. Place the PCB assembly on the heat sink/amplifier assembly so that the hex spacers come through the aligning holes near the corners of the amplifier location in the PCB. Carefully lower the PCB assembly until the pins of the amplifier engage the cage jacks and then continue pushing the PCB assembly in the area between the amplifier's pins until the four spacer grommets at the four corners of the PCB touch the heat sink. At this point the PCB should not be bowed.
12. Use #8 X 1" sheet metal screws to mount the PCB to the heat sink at the four spacer-grommets.
13. #8 hex stand offs (2221) are also provided with the kit. Install the # 8 x 0.375" screws (91735A190), provided with the kit, from the component side. Attach the standoffs to these screws on the corners of the board. Refer to the assembly drawings while installing the standoffs.
14. Connect the external connections via the BNC connector and terminal strip. Hook up power supply and signals as necessary. The amplifier is now ready for testing.

Figure 2: Top Assembly

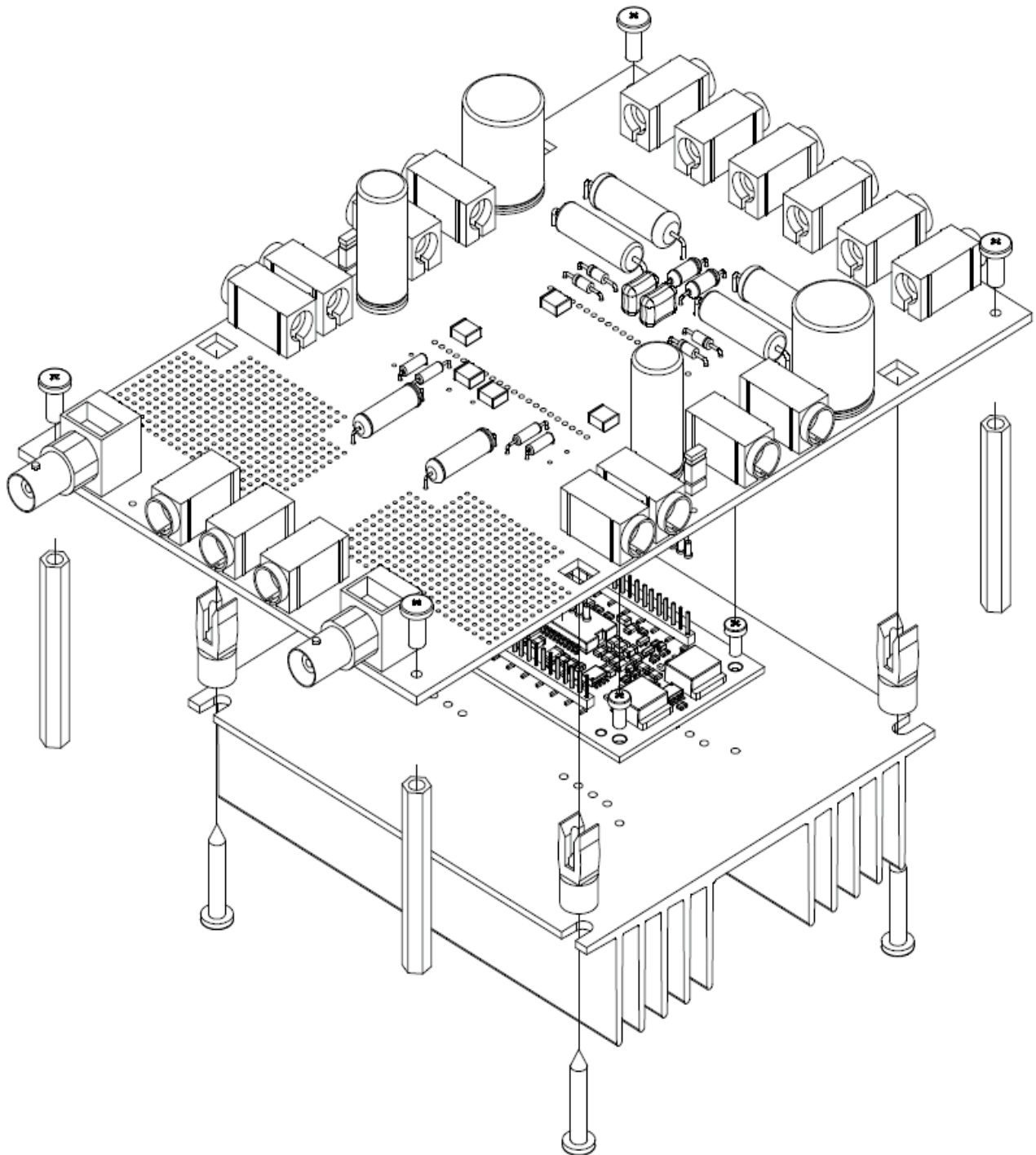
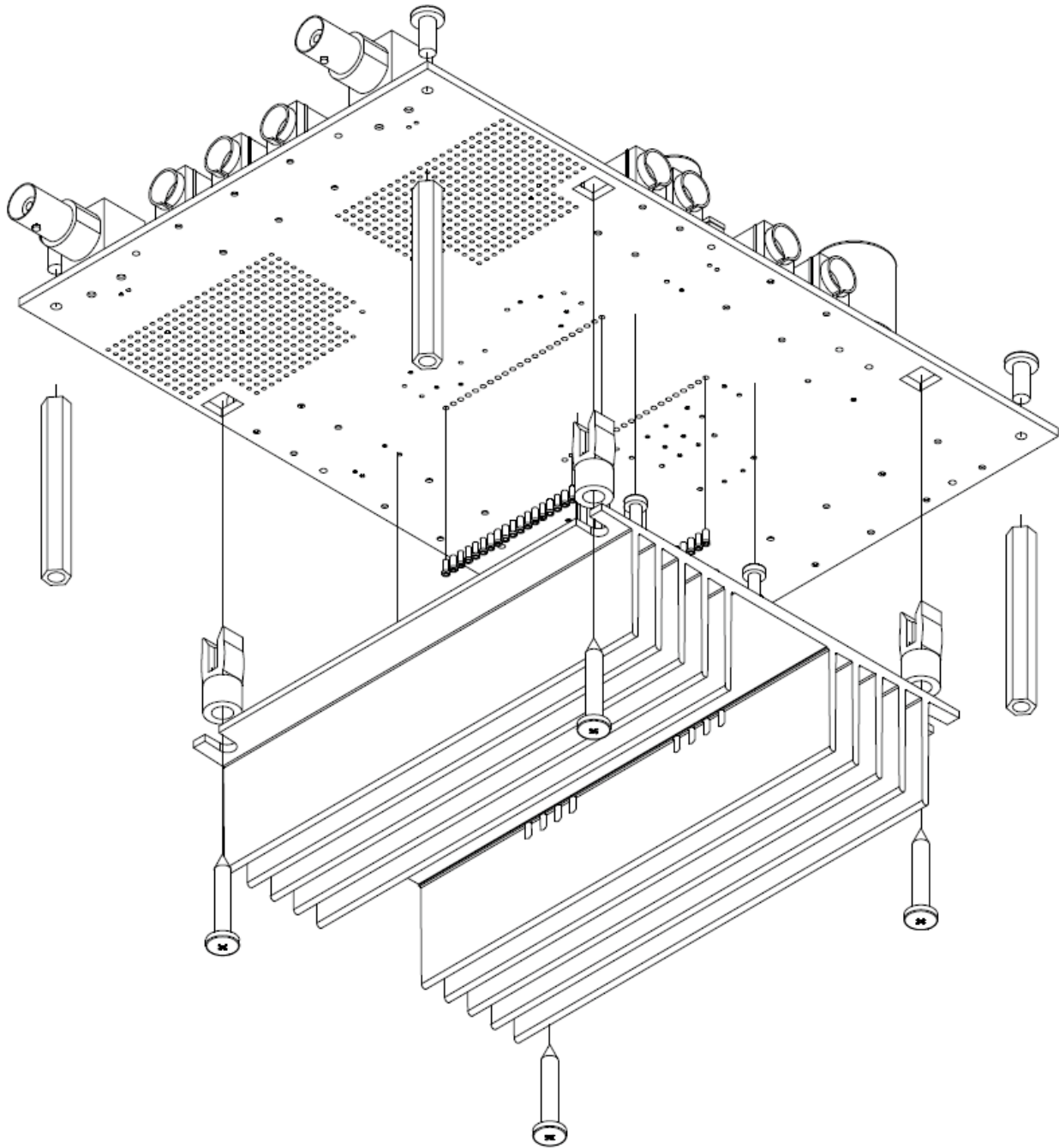

Figure 3: Bottom Assembly



TEST ASSEMBLY

EQUIPMENT NEEDED

1. Power Supply
2. Function Generator
3. Oscilloscope
4. Proper Heat Sink System (if operating at high current)

TEST SETUP

Connect the positive power supply to banana jacks P8 and P17. Since the negative supply is grounded, connect the ground connection of the positive supply to jacks P9 and P16. Connect the auxiliary supply to jacks P3, P4 and P5. Connect the BNC cable from the function generator to the BNC connector IN_A and/or IN_B based on the required channel to be used. If using a reactive load, connect the RISO resistor to banana jack Out_A1/Out_B1. If using a resistive load, connect the load to banana jack Out_A2/Out_B2. Out_A2 and Out_B2 are shorted across the RISO resistor (refer figure 1). Refer to the amplifier datasheet for typical values of input voltage, frequency and supply voltage. Input and output waveforms can be checked on an Oscilloscope by connecting it to the test points mounted on the board. Begin the test with minimum values of input and supply voltage.

Note: For added precaution, power on the circuit with the amplifier removed. Check the voltage at each cage jack without the DUT, for correct voltage / signal at each respective pin. Once this is done, plug in the DUT and check for the correct signal

TEST RESULTS

The input is set to 1.5V, with a -200mV offset, and the output is 97.5V. The test results can be seen in figure 4. The input of the amplifier is shown in Yellow color and the output of the amplifier is shown in Blue color. The input of the amplifier is set with a fixed rising edge and falling edge slew rate. The output is 65 times that of the input. The output current flowing through the capacitor is shown by the magenta colored waveform.

Figure 4: Output Waveforms

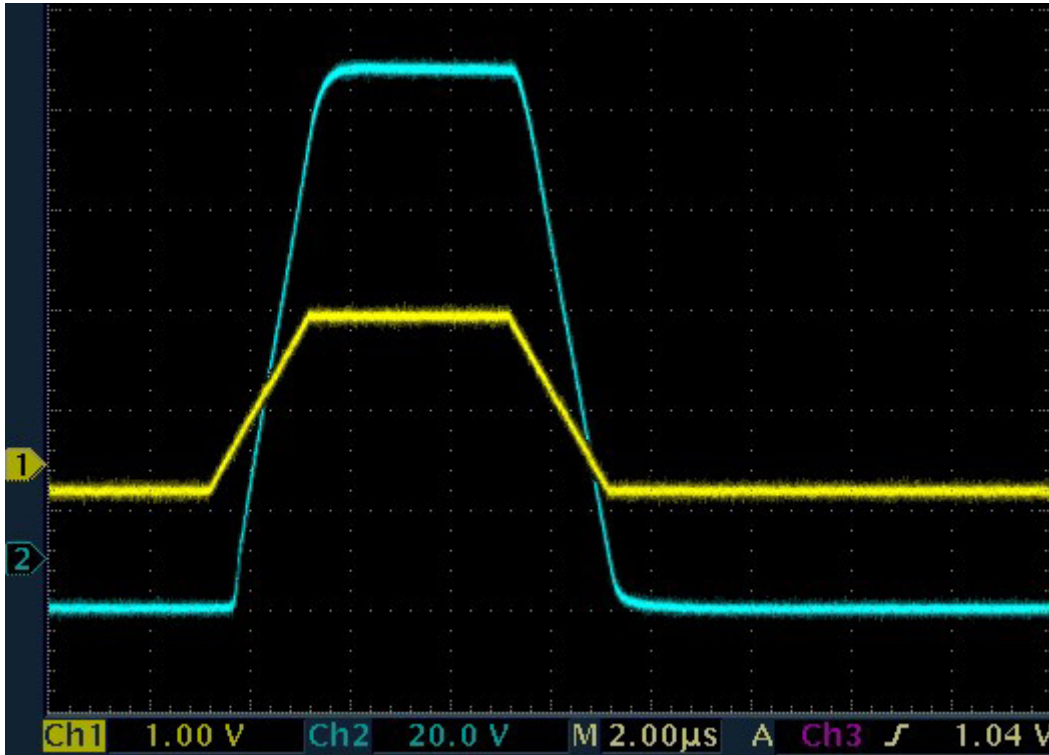

NEED TECHNICAL HELP? CONTACT APEX SUPPORT!

For all Apex Microtechnology product questions and inquiries, call toll free 800-546-2739 in North America. For inquiries via email, please contact apex.support@apexanalog.com. International customers can also request support by contacting their local Apex Microtechnology Sales Representative. To find the one nearest to you, go to www.apexanalog.com

IMPORTANT NOTICE

Apex Microtechnology, Inc. has made every effort to insure the accuracy of the content contained in this document. However, the information is subject to change without notice and is provided "AS IS" without warranty of any kind (expressed or implied). Apex Microtechnology reserves the right to make changes without further notice to any specifications or products mentioned herein to improve reliability. This document is the property of Apex Microtechnology and by furnishing this information, Apex Microtechnology grants no license, expressed or implied under any patents, mask work rights, copyrights, trademarks, trade secrets or other intellectual property rights. Apex Microtechnology owns the copyrights associated with the information contained herein and gives consent for copies to be made of the information only for use within your organization with respect to Apex Microtechnology integrated circuits or other products of Apex Microtechnology. This consent does not extend to other copying such as copying for general distribution, advertising or promotional purposes, or for creating any work for resale.

APEX MICROTECHNOLOGY PRODUCTS ARE NOT DESIGNED, AUTHORIZED OR WARRANTED TO BE SUITABLE FOR USE IN PRODUCTS USED FOR LIFE SUPPORT, AUTOMOTIVE SAFETY, SECURITY DEVICES, OR OTHER CRITICAL APPLICATIONS. PRODUCTS IN SUCH APPLICATIONS ARE UNDERSTOOD TO BE FULLY AT THE CUSTOMER OR THE CUSTOMER'S RISK.

Apex Microtechnology, Apex and Apex Precision Power are trademarks of Apex Microtechnology, Inc. All other corporate names noted herein may be trademarks of their respective holders.