



Chipsmall Limited consists of a professional team with an average of over 10 year of expertise in the distribution of electronic components. Based in Hongkong, we have already established firm and mutual-benefit business relationships with customers from,Europe,America and south Asia,supplying obsolete and hard-to-find components to meet their specific needs.

With the principle of “Quality Parts,Customers Priority,Honest Operation,and Considerate Service”,our business mainly focus on the distribution of electronic components. Line cards we deal with include Microchip,ALPS,ROHM,Xilinx,Pulse,ON,Everlight and Freescale. Main products comprise IC,Modules,Potentiometer,IC Socket,Relay,Connector.Our parts cover such applications as commercial,industrial, and automotives areas.

We are looking forward to setting up business relationship with you and hope to provide you with the best service and solution. Let us make a better world for our industry!



Contact us

Tel: +86-755-8981 8866 Fax: +86-755-8427 6832

Email & Skype: info@chipsmall.com Web: www.chipsmall.com

Address: A1208, Overseas Decoration Building, #122 Zhenhua RD., Futian, Shenzhen, China





Introduction

The EK3L02AL is an Evaluation Kit designed to provide the user with a complete, ready-to-use platform for the evaluation of the LIS3L02AL, a low-power 3-Axis linear capacitive accelerometer that includes a sensing element and an IC interface able to take information from the sensing element and to provide an analog signal to the external world.

Besides the MEMS sensor, the system mounts a linear voltage regulator and a rail to rail Low noise Quad amplifier configured as non-inverting buffer thus making both direct sensor outputs and buffered sensor outputs available to the user.

The kit provides also an easy way to control its Self-Test (ST) pin.

Obsolete Product(s) - Obsolete Product(s)

Contents

- 1 Evaluation Kit Description 3**
 - 1.1 Operating the Evaluation Kit 4
 - 1.2 Driving ST signal 5
 - 1.2.1 Self-Test 5

- 2 Schematic Diagram 6**

- 3 Bill Of Material 7**

- 4 Revision History 8**

Obsolete Product(s) - Obsolete Product(s)

1 Evaluation Kit Description

The EK3L02AL is an Evaluation Kit designed to provide the user with a complete, ready-to-use platform for the evaluation of the LIS3L02AL 3-axis analog output linear accelerometer. The block diagram of the evaluation kit and the top silk-screen of the board are shown respectively in *Figure 1* and *Figure 2* while the photo of the full board is given in *Figure 3*.

Figure 1. Evaluation Board Block Diagram

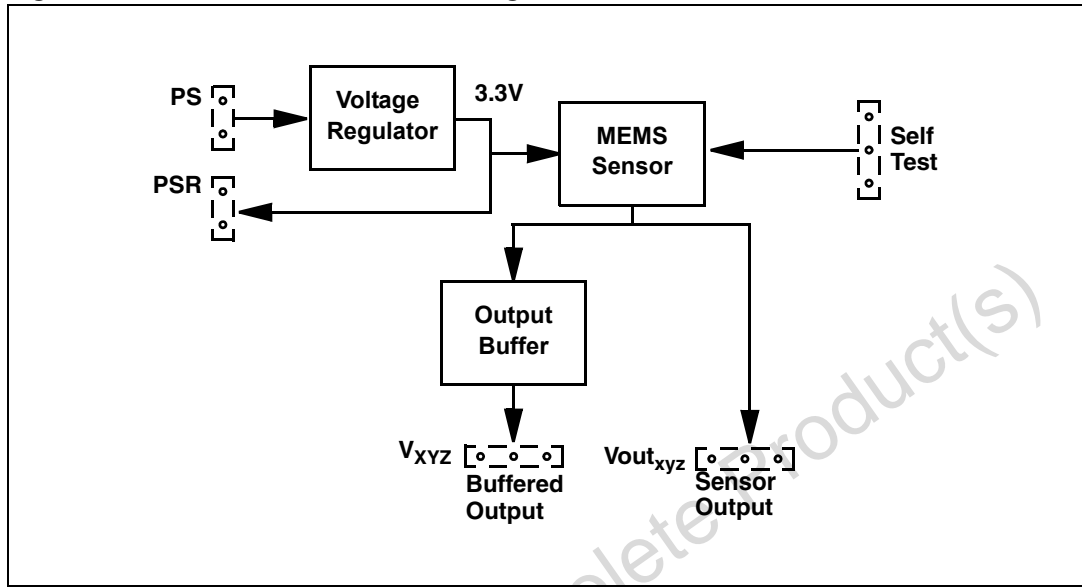

Figure 2. Top silk-screen for EK3L02AL board layout

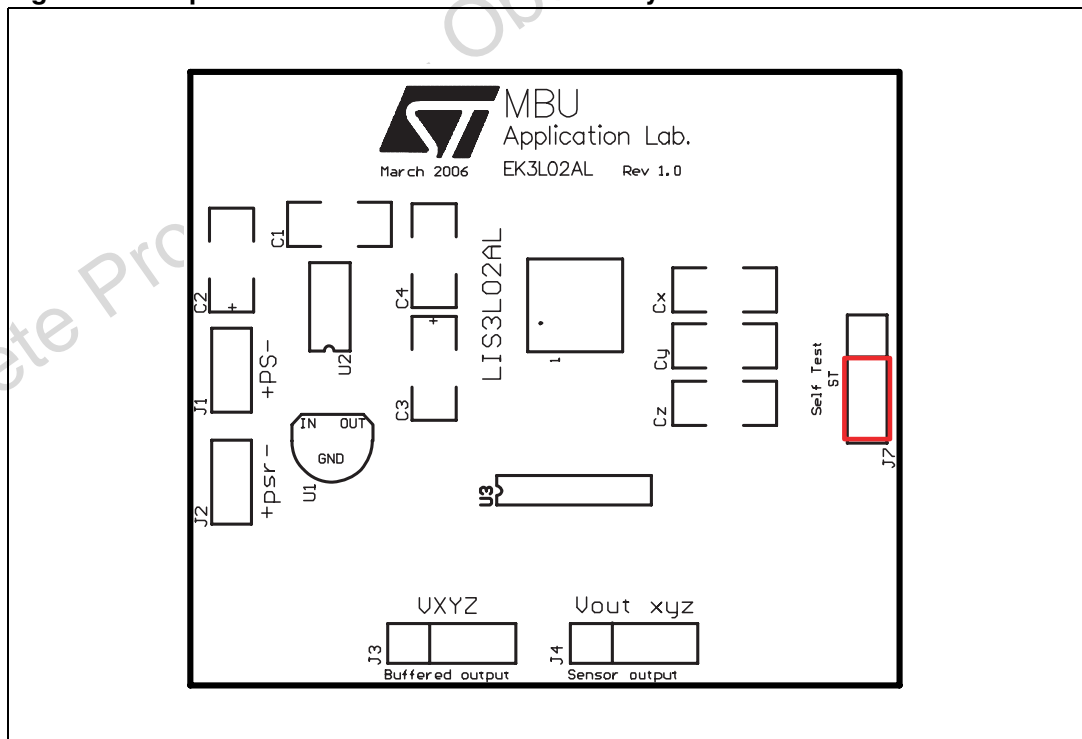
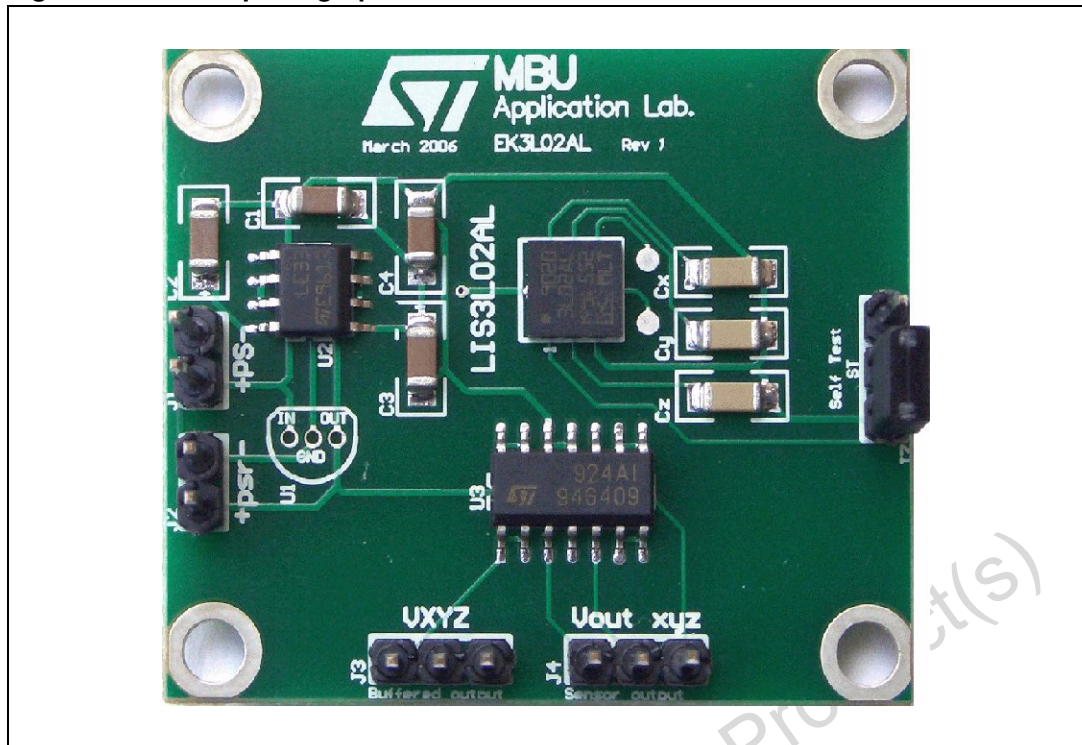

Figure 3. Board photograph



1.1 Operating the Evaluation Kit

To operate the evaluation kit it is necessary to supply it through the connector marked as J1 (PS) with a dc voltage comprised between 3.7V and 18V. The suggested supply voltage is 5V. The typical current consumption of the LIS3L02AL MEMS sensor is 0.85 mA while the typical current consumption of the whole board is in the range of 6 mA.

The voltage applied to the board is then regulated through a linear voltage regulator which supplies the MEMS sensor at 3.3V.

The outputs (Voutx, Vouty and Voutz) of the LIS3L02AL linear accelerometer are band limited through the usage of three capacitors Cx, Cy and Cz of 1.5nF which, together with the output resistance $R_{out}=110K\Omega$ of the sensor, create a single-pole low-pass filter having a cut-off frequency of about 1KHz.

In case a different cut-off frequency f_t is required, the above capacitances must be replaced by the users with other components having the value given by the following formula:

$$C(x, y, z) = \frac{1}{2 \cdot \pi \cdot R_{out} \cdot f_t}$$

As anticipated above, the EK3L02AL makes both the direct sensor outputs and the buffered signals available to the outside through two different connectors which are named respectively J4 (Sensor output) and J3 (Buffered output). In particular the three channels are made available going from the left to the right of the board in the order Vout_x, Vout_y and Vout_z.

The buffering of the sensor outputs is obtained through the usage of a rail-to-rail low-noise quad-amplifier configured as non-inverting buffer.

1.2 Driving ST signal

The board allows to control ST (Self Test) signal through the usage of a test point (marked J7) and a jumper.

1.2.1 Self-Test

When the jumper related to J7 (ST) is either inserted as marked highlighted by the red box in [Figure 2](#) or completely removed from the board the self-test feature is disabled.

In order to activate the self-test feature the afore said jumper must be into J7 so to short-circuit its central and upper pins.

When this function is activated the seismic mass of the sensor is moved by means of an electrostatic test-force simulating a definite input acceleration. Under these conditions the sensor outputs will exhibit a voltage change in their DC levels as specified in the datasheet of the LIS3L02AL sensor.

Obsolete Product(s) - Obsolete Product(s)

2 Schematic Diagram

The schematic diagram of the EK3L02AL evaluation kit is shown in [Figure 4](#).

Figure 4. Schematic diagram for EK3L02AL board

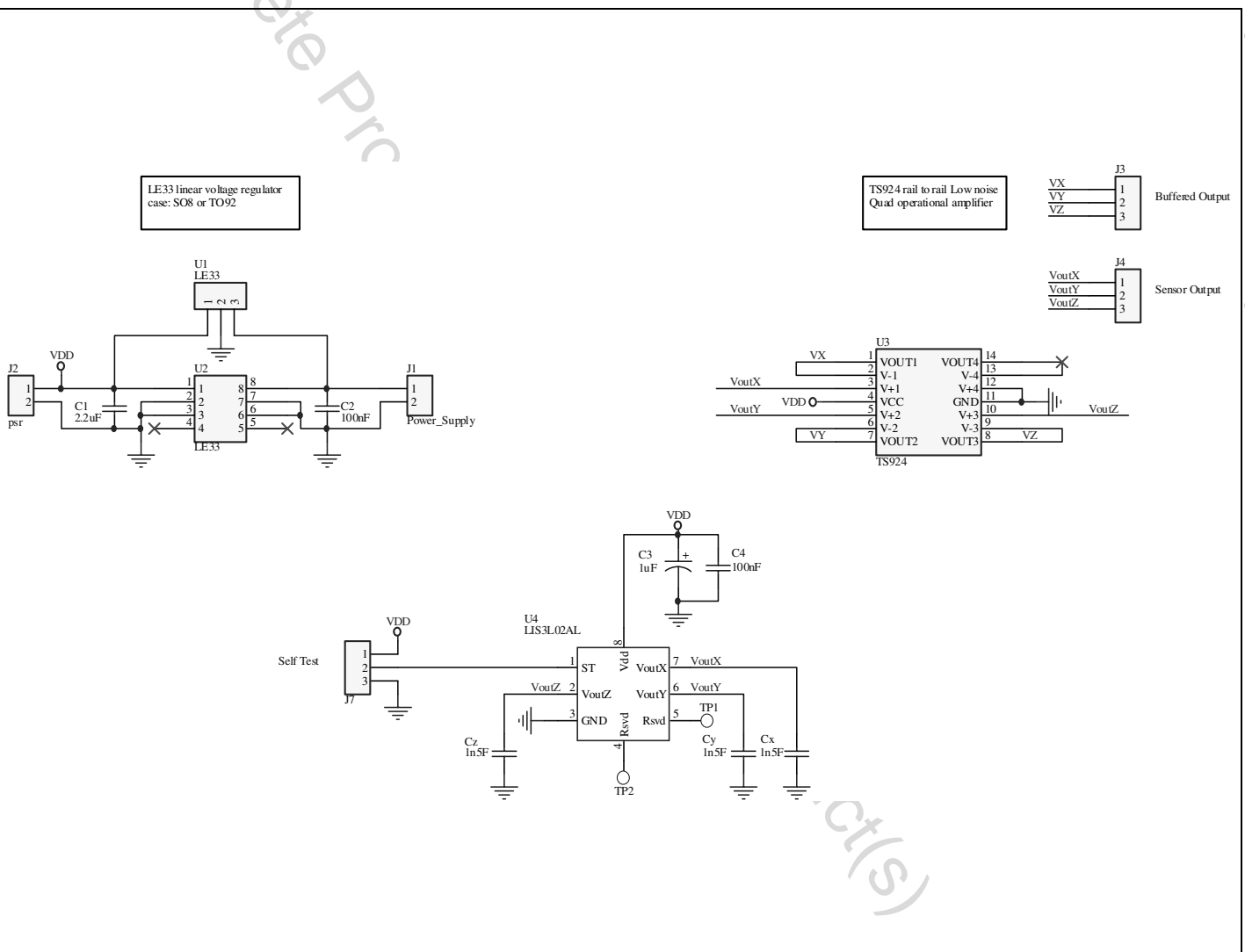

Obsolete Proc

3 Bill Of Material

The Bill of Material for EK3L02AL evaluation kit is given in [Table 1](#)

Table 1. Bill Of Material

Item	Quantity	Reference	Value
1	2	C2,C4	100nF
2	1	C1	2.2uF
3	3	Cx,Cy,Cz	1.5nF
4	1	C3	1uF
5	2	J1,J2	CON2
6	3	J3,J4,J7	CON3
7	1	U2	LE33
8	1	U3	TS924
9	1	U4	LIS3L02AL

4 Revision History

Table 2. Document revision history

Date	Revision	Changes
07-Jun-2006	1	Initial release.

Obsolete Product(s) - Obsolete Product(s)

Please Read Carefully:

Information in this document is provided solely in connection with ST products. STMicroelectronics NV and its subsidiaries ("ST") reserve the right to make changes, corrections, modifications or improvements, to this document, and the products and services described herein at any time, without notice.

All ST products are sold pursuant to ST's terms and conditions of sale.

Purchasers are solely responsible for the choice, selection and use of the ST products and services described herein, and ST assumes no liability whatsoever relating to the choice, selection or use of the ST products and services described herein.

No license, express or implied, by estoppel or otherwise, to any intellectual property rights is granted under this document. If any part of this document refers to any third party products or services it shall not be deemed a license grant by ST for the use of such third party products or services, or any intellectual property contained therein or considered as a warranty covering the use in any manner whatsoever of such third party products or services or any intellectual property contained therein.

UNLESS OTHERWISE SET FORTH IN ST'S TERMS AND CONDITIONS OF SALE ST DISCLAIMS ANY EXPRESS OR IMPLIED WARRANTY WITH RESPECT TO THE USE AND/OR SALE OF ST PRODUCTS INCLUDING WITHOUT LIMITATION IMPLIED WARRANTIES OF MERCHANTABILITY, FITNESS FOR A PARTICULAR PURPOSE (AND THEIR EQUIVALENTS UNDER THE LAWS OF ANY JURISDICTION), OR INFRINGEMENT OF ANY PATENT, COPYRIGHT OR OTHER INTELLECTUAL PROPERTY RIGHT.

UNLESS EXPRESSLY APPROVED IN WRITING BY AN AUTHORIZED REPRESENTATIVE OF ST, ST PRODUCTS ARE NOT DESIGNED, AUTHORIZED OR WARRANTED FOR USE IN MILITARY, AIR CRAFT, SPACE, LIFE SAVING, OR LIFE SUSTAINING APPLICATIONS, NOR IN PRODUCTS OR SYSTEMS, WHERE FAILURE OR MALFUNCTION MAY RESULT IN PERSONAL INJURY, DEATH, OR SEVERE PROPERTY OR ENVIRONMENTAL DAMAGE.

Resale of ST products with provisions different from the statements and/or technical features set forth in this document shall immediately void any warranty granted by ST for the ST product or service described herein and shall not create or extend in any manner whatsoever, any liability of ST.

ST and the ST logo are trademarks or registered trademarks of ST in various countries.

Information in this document supersedes and replaces all information previously supplied.

The ST logo is a registered trademark of STMicroelectronics. All other names are the property of their respective owners.

© 2006 STMicroelectronics - All rights reserved

STMicroelectronics group of companies

Australia - Belgium - Brazil - Canada - China - Czech Republic - Finland - France - Germany - Hong Kong - India - Israel - Italy - Japan - Malaysia - Malta - Morocco - Singapore - Spain - Sweden - Switzerland - United Kingdom - United States of America

www.st.com