



Chipsmall Limited consists of a professional team with an average of over 10 year of expertise in the distribution of electronic components. Based in Hongkong, we have already established firm and mutual-benefit business relationships with customers from,Europe,America and south Asia,supplying obsolete and hard-to-find components to meet their specific needs.

With the principle of “Quality Parts,Customers Priority,Honest Operation,and Considerate Service”,our business mainly focus on the distribution of electronic components. Line cards we deal with include Microchip,ALPS,ROHM,Xilinx,Pulse,ON,Everlight and Freescale. Main products comprise IC,Modules,Potentiometer,IC Socket,Relay,Connector.Our parts cover such applications as commercial,industrial, and automotives areas.

We are looking forward to setting up business relationship with you and hope to provide you with the best service and solution. Let us make a better world for our industry!



Contact us

Tel: +86-755-8981 8866 Fax: +86-755-8427 6832

Email & Skype: info@chipsmall.com Web: www.chipsmall.com

Address: A1208, Overseas Decoration Building, #122 Zhenhua RD., Futian, Shenzhen, China



Evaluation Kit

APPLICABLE PARTS (SOLD SEPARATELY)

- PB63/PB64 Power Booster

INTRODUCTION

This easy-to-use kit provides a platform for the evaluation of the PB63/PB64 high voltage power boosters. The PB63/PB64 is designed most commonly in combination with a small signal, general purpose op amp. However, they can also be used without a driver amplifier. This kit can be used to analyze a multitude of standard or proprietary circuit configurations.

Figure 1: PCB Layout

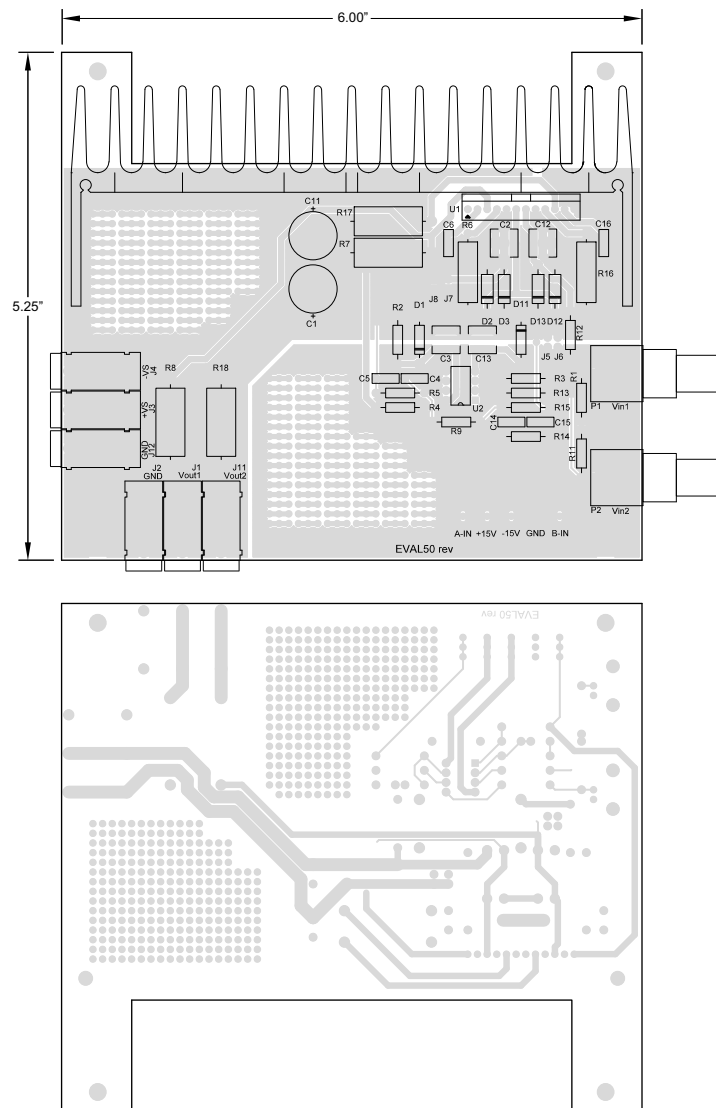
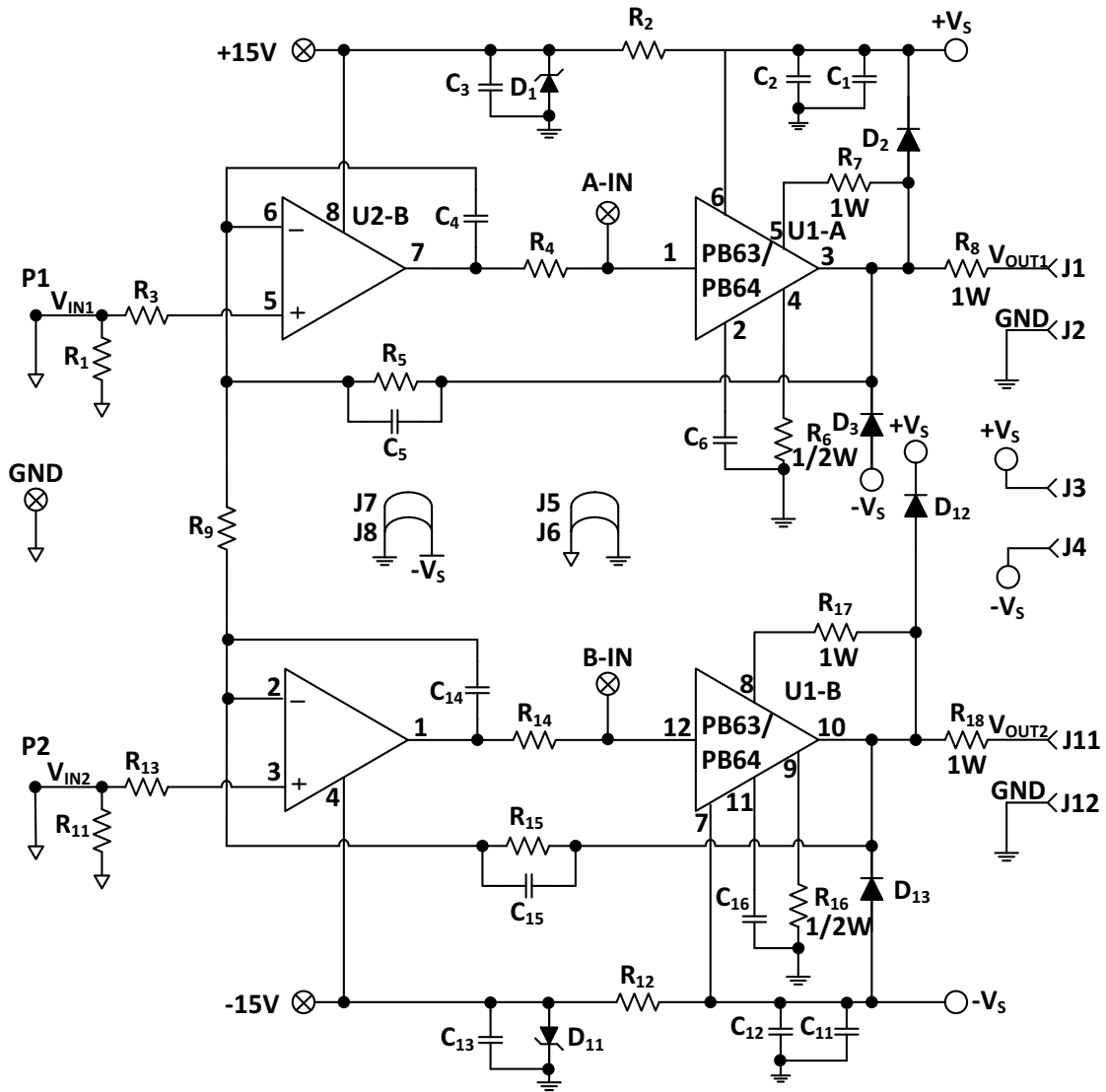

Figure 2: Equivalent Schematic



SUGGESTED CIRCUIT COMPONENT DESCRIPTIONS

Component	Description
R1, R11	51.1 Ω, Input Termination Resistor
R2, R12	10 kΩ, Shunt Regulator Bias Resistor
R3, R9, R13	2.21 kΩ, Input Resistor
R4, R14	Zero Ω, Short
R5, R15	49.9 kΩ, Feedback Resistor
R6, R16	499 Ω, Booster Gain Set Resistor
R7, R17	0.39 Ω, Current Limit Resistor
R8, R18	Zero Ω, Short (Load Isolation Resistor)
C1, C11	33 μF, 200 V, Electrolytic Bypass Capacitor
C2, C12, C3, C13	1 μF, 200V, Ceramic Bypass Capacitor
C4, C14, C6, C16	10 pF, Silver Mica Compensation Capacitor
C5, C15	Open
U2	LT1355, Dual Operational Amplifier
D1, D11	15 V, Zener Diode, BZX79-C15
D2, D3, D12, D13	Ultra-Fast Recovery Output Protection Diodes, MUR140
J5, J6	Optional Jumper, Signal Ground To Power Ground
J7, J8	Optional Jumper, Power Ground To -VS

SUGGESTED EVALUATION CIRCUIT DESCRIPTION

The circuit is configured as a differential input, differential output power amplifier. This topology allows the user to evaluate each channel of the PB63/PB64 independently as a single ended driver or simultaneously operating in bridge mode. The circuit will accept a true differential input signal as well as a single ended input signal applied to either input. The voltage gain is approximately 46 Volts per Volt with the component values specified in the table. Please refer to the schematic diagram.

$$GAIN = \frac{R5 + R15}{R9} + 1$$

CAUTION

Use the supplied thermal washers or thermal grease between the power amplifier and the heat sink.

PARTS LIST

Reference	Part #	Description	QTY
	HS20	Heatsink	1
	EVAL50	PC Board	1
MS06	310-43-120-41-001000	Socket-0.015-0.025 Dia. Pins	1 Pkg (2 Pcs)
	TW07	Thermal Washer	1 Pkg (10 Pcs)
C2, C12, C13, C3	1825B105K201N	Cap, 1 μ F, 200V, 10%-R	4
	146511	Connector, BNC	2
	571-0100	Connector, Banana	6

BEFORE YOU GET STARTED

- All Apex Microtechnology amplifiers should be handled using proper ESD precautions.
- Always use the heat sink and thermal washers included in this kit.
- Always use adequate power supply bypassing.
- Do not change connections while the circuit is powered.
- Initially set all power supplies to the minimum operating levels allowed in the device data sheet.
- Check for oscillations.
- Please refer to Application Note, AN01 for general operating considerations.

ASSEMBLY

1. On the silk screen side of the evaluation board, insert and solder the MS06 mating socket in DUT holes 1-12. Be sure each one is fully seated.
2. Solder components for your circuit. Be sure to include proper bypassing, required compensation components and current limit resistors. See the op amp data sheet for help in selecting these components.
3. Place the TW07 thermal washer on the heat sink over the mounting hole for the DUT. Place a #6 screw through the mounting hole and thread a #6 nut onto the screw at the back of the heat sink. Do not tighten. Note that there are two sets of mounting holes on the HS20. Holes on one edge allow room between the DUT and evaluation board for the MS06 socket. The holes on the other edge are for direct through hole mounting of the DUT to the evaluation board. It is recommended that you use the MS06.
4. Mount the DUT to the HS20 by sliding under the head of the #6 screw and on top of the thermal washer. Tighten the nut to the specified 8 to 10 in-lbs. (0.9 to 1.3 N*m) do not over torque.
5. Install leads of the DUT into the MS06 on the evaluation board. Use #6 self-tapping screws to secure the evaluation board to the HS20 heatsink as shown in the assembly diagram (Figure 3).

Figure 3: Assembly Diagram

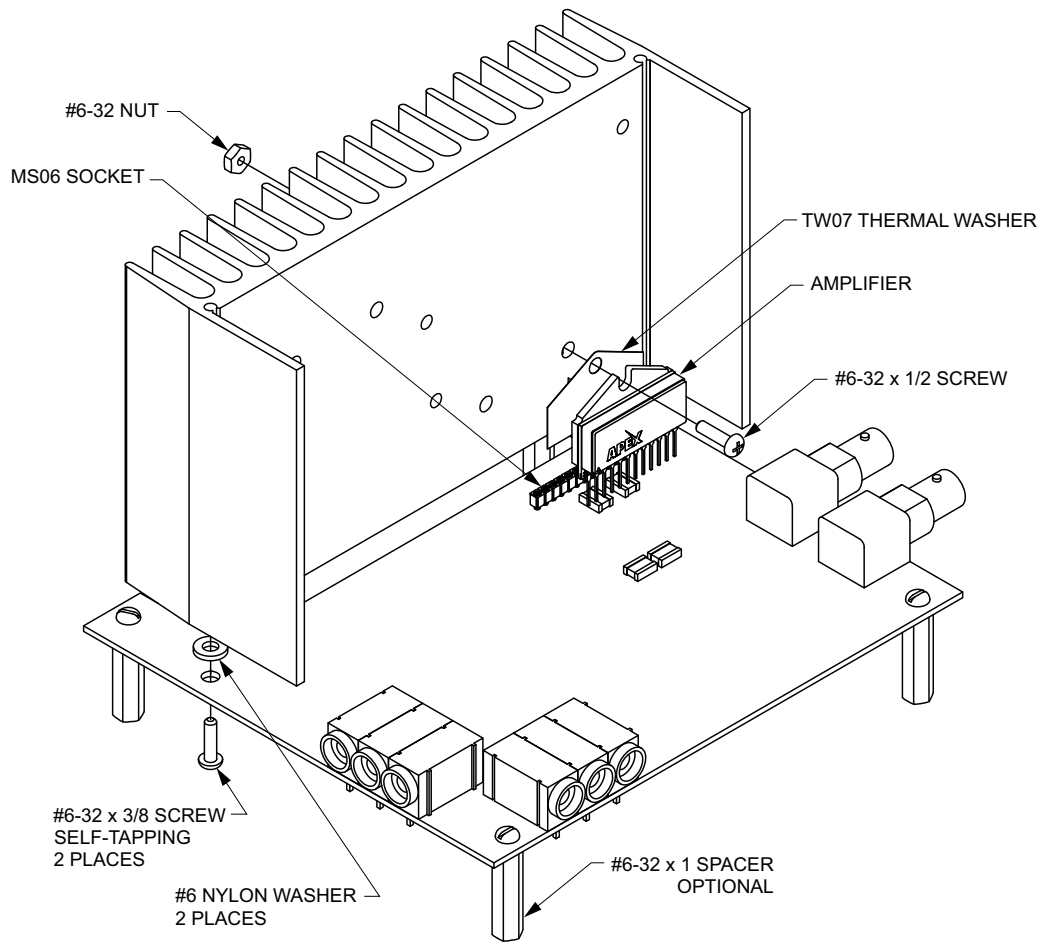

NEED TECHNICAL HELP? CONTACT APEX SUPPORT!

For all Apex Microtechnology product questions and inquiries, call toll free 800-546-2739 in North America. For inquiries via email, please contact apex.support@apexanalog.com. International customers can also request support by contacting their local Apex Microtechnology Sales Representative. To find the one nearest to you, go to www.apexanalog.com

IMPORTANT NOTICE

Apex Microtechnology, Inc. has made every effort to insure the accuracy of the content contained in this document. However, the information is subject to change without notice and is provided "AS IS" without warranty of any kind (expressed or implied). Apex Microtechnology reserves the right to make changes without further notice to any specifications or products mentioned herein to improve reliability. This document is the property of Apex Microtechnology and by furnishing this information, Apex Microtechnology grants no license, expressed or implied under any patents, mask work rights, copyrights, trademarks, trade secrets or other intellectual property rights. Apex Microtechnology owns the copyrights associated with the information contained herein and gives consent for copies to be made of the information only for use within your organization with respect to Apex Microtechnology integrated circuits or other products of Apex Microtechnology. This consent does not extend to other copying such as copying for general distribution, advertising or promotional purposes, or for creating any work for resale.

APEX MICROTECHNOLOGY PRODUCTS ARE NOT DESIGNED, AUTHORIZED OR WARRANTED TO BE SUITABLE FOR USE IN PRODUCTS USED FOR LIFE SUPPORT, AUTOMOTIVE SAFETY, SECURITY DEVICES, OR OTHER CRITICAL APPLICATIONS. PRODUCTS IN SUCH APPLICATIONS ARE UNDERSTOOD TO BE FULLY AT THE CUSTOMER OR THE CUSTOMER'S RISK.

Apex Microtechnology, Apex and Apex Precision Power are trademarks of Apex Microtechnology, Inc. All other corporate names noted herein may be trademarks of their respective holders.