



Chipsmall Limited consists of a professional team with an average of over 10 year of expertise in the distribution of electronic components. Based in Hongkong, we have already established firm and mutual-benefit business relationships with customers from,Europe,America and south Asia,supplying obsolete and hard-to-find components to meet their specific needs.

With the principle of “Quality Parts,Customers Priority,Honest Operation,and Considerate Service”,our business mainly focus on the distribution of electronic components. Line cards we deal with include Microchip,ALPS,ROHM,Xilinx,Pulse,ON,Everlight and Freescale. Main products comprise IC,Modules,Potentiometer,IC Socket,Relay,Connector.Our parts cover such applications as commercial,industrial, and automotives areas.

We are looking forward to setting up business relationship with you and hope to provide you with the best service and solution. Let us make a better world for our industry!



Contact us

Tel: +86-755-8981 8866 Fax: +86-755-8427 6832

Email & Skype: info@chipsmall.com Web: www.chipsmall.com

Address: A1208, Overseas Decoration Building, #122 Zhenhua RD., Futian, Shenzhen, China



Dual Channel Differential DSL Line Driver

The EL1528 is a dual channel differential amplifier designed for driving full rate ADSL signals at very low power dissipation. The high drive capability of 450mA makes this driver ideal for both CAP and DMT designs. It contains two pairs of wideband, high-voltage, current mode feedback amplifiers optimized for low power consumption in DSL systems.

These drivers achieve an MTPR distortion measurement of better than 70dB, while consuming typically 5mA per DSL channel of total supply current. This supply current can be set using a resistor on the I_{ADJ} pin. Two other pins (C₀ & C₁) can also be used to adjust supply current to one of four pre-set modes (full-I_S, 3/4-I_S, 1/2-I_S, and full power-down). The EL1528 operates on ±5V to ±12V supplies and retains its bandwidth and linearity over the complete supply range.

The device is supplied in a thermally-enhanced 20-pin HTSSOP and the small footprint (4x5mm) 24-pin QFN packages. The EL1528 is specified for operation over the full -40°C to +85°C temperature range.

Features

- Pb-free available
- 450mA output drive capability
- 44.4V_{P-P} differential output drive into 100Ω
- -75dBc THD @ 500kHz 16V_{P-P}
- MTPR of -70dB
- Operates down to 2mA per amplifier supply current
- Current control pins
- Channel separation
 - 80dB @ 500kHz
 - 75dB @ 1MHz
- Pb-free available (RoHS compliant)

Applications

- Dual port ADSL line drivers
- HDSL line drivers
- VDSL line drivers

Pinouts

**EL1528
(24-PIN QFN)
TOP VIEW**

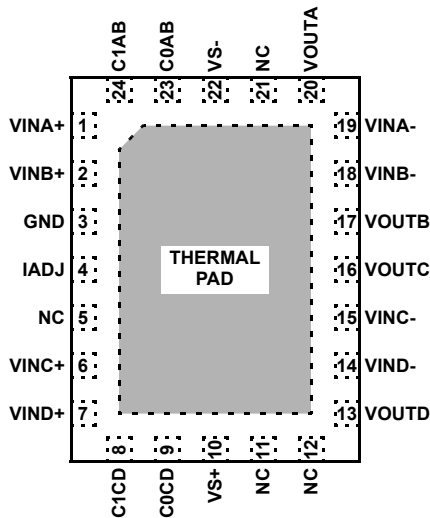

**EL1528
(20-PIN HTSSOP)
TOP VIEW**

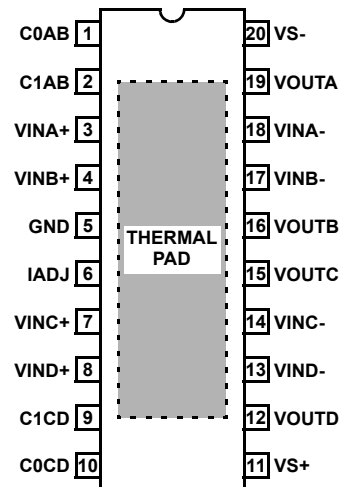

All Intersil U.S. products are manufactured, assembled and tested utilizing ISO9001 quality systems.
Intersil Corporation's quality certifications can be viewed at www.intersil.com/design/quality

Intersil products are sold by description only. Intersil Corporation reserves the right to make changes in circuit design, software and/or specifications at any time without notice. Accordingly, the reader is cautioned to verify that data sheets are current before placing orders. Information furnished by Intersil is believed to be accurate and reliable. However, no responsibility is assumed by Intersil or its subsidiaries for its use; nor for any infringements of patents or other rights of third parties which may result from its use. No license is granted by implication or otherwise under any patent or patent rights of Intersil or its subsidiaries.

For information regarding Intersil Corporation and its products, see www.intersil.com