



Chipsmall Limited consists of a professional team with an average of over 10 year of expertise in the distribution of electronic components. Based in Hongkong, we have already established firm and mutual-benefit business relationships with customers from,Europe,America and south Asia,supplying obsolete and hard-to-find components to meet their specific needs.

With the principle of “Quality Parts,Customers Priority,Honest Operation,and Considerate Service”,our business mainly focus on the distribution of electronic components. Line cards we deal with include Microchip,ALPS,ROHM,Xilinx,Pulse,ON,Everlight and Freescale. Main products comprise IC,Modules,Potentiometer,IC Socket,Relay,Connector.Our parts cover such applications as commercial,industrial, and automotives areas.

We are looking forward to setting up business relationship with you and hope to provide you with the best service and solution. Let us make a better world for our industry!



Contact us

Tel: +86-755-8981 8866 Fax: +86-755-8427 6832

Email & Skype: info@chipsmall.com Web: www.chipsmall.com

Address: A1208, Overseas Decoration Building, #122 Zhenhua RD., Futian, Shenzhen, China



Energy Management Energy Analyzer Type EM210

CARLO GAVAZZI

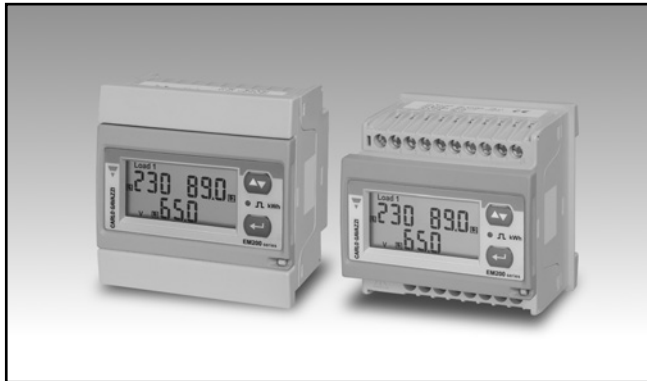

- Multi-use housing: for both DIN-rail and panel mounting applications
- Current inputs AV option: CT 5A
- Current inputs MV option: current sensor 333 mV (CTV series) or ROG4K, Rogowski coil by Carlo Gavazzi without necessity of external integrator
- Class B (kWh) according to EN50470-3
- Class 1 (kWh) according to EN62053-21
- Class 2 (kvarh) according to EN62053-23
- Accuracy ± 0.5 RDG (current/voltage)
- Energy meter
- Instantaneous variables readout: 3 DGT
- Energies readout: 7 DGT
- System variables: W, var, PF, Hz, Phase-sequence.
- Single phase variables: VLL, VLN, A, PF, THD (A,V, up to the 15th harmonic)
- Energy measurements: total kWh (imported and exported); kvarh
- TRMS measurements of distorted sine waves (voltages/currents)
- Self power supply
- Dimensions: 4-DIN modules and 72x72mm
- Protection degree (front): IP40
- Application adaptable display and programming procedure (Easyprog function)
- Easy connections management
- Detachable display

Product description

Three-phase energy meter with removable front LCD display unit. The same unit can be used either as a DIN-rail mounting or a panel mounting energy meter. This general purpose three-phase energy meter is suitable for both active and reactive energy metering for cost allocation but also for main electrical parameter meas-

urement and retransmission (transducer function). Possibility to display also exported active energy (e.g. in case of regenerated energy in lifts or similar applications) harmonic distortion information are available for the voltages and the currents, up to the 15th harmonic. An hourcounter meter is available to link the energy consumption to the

relevant working hours and an hourcounter to link the exported energy to production hours. Housing for DIN-rail mounting with IP40 (front) protection degree. Current measurements carried out by means of external current transformers transformers, 5A or 333mV (CTV series), or ROG4K, Rogowski coil solution without external integra-

tor. Voltage measurements carried out either by means of direct connection or by means of potential transformers. EM210 is provided, as standard, with a pulsating output for active energy retransmission. In addition a 2-wire RS485 communication port is available as an option.

How to order

EM210 72D AV5 3 X O X X



Type Selection

Range code	System	Power supply	Options
AV5: 230/400VLL AC, 5(6) A or 1(6)A (*) (CT connection)	3: balanced and unbalanced load: 3-phase, 4-wire; 3-phase, 3-wire (without N connection); 2-phase, 3-wire; 1-phase, 2-wire	X: Self power supply from 40V to 480VAC LL, 45 to 65 Hz (connection VL2-VL3)	X: none
AV6: 120/230VLL AC 5(6)A or 1(6)A (*) (VT/PT and CT connections)			
MV5: 230/400VLL AC, 0.333V (current sensor CTV series or ROG4K connection)			
MV6: 120/230VLL AC, 0.333V (VT/PT and current sensor CTV series or ROG4K connection)			
Output 1	Output 2	(*) the range 1(6)A is available but not in compliance with the EN50470-3 standard.	
O: Single static output (opto-mosfet)	X: None S: RS485 port		

Input specification

Rated Input	System type: 3	Display refresh time	1 second
Current type	Not isolated (shunt inputs). Note: the external current transformers can be connected to earth individually.	Display	2 lines 1st line: 7-DGT or 3-DGT+3-DGT 2nd line: 3-DGT LCD, h 7mm.
Current range AV5, AV6	In: primary current corresponding to 5 A secondary output. Imax: 1.2 In (6A secondary). Note: The "1(6) A" range is available but not in compliance with the EN50470-3 standard.	Type	3-DGT.
Current range MV5, MV6	In: primary current corresponding to 0.333 V secondary output. Imax: 1.2 In (0.4V secondary).	Instantaneous variables read-out	Total: 5+2, 6+1 or 7DGT
Voltage (direct or by VT/PT)	AV5, MV5: 230/400VLL; 6A; Un: 160 to 240VLN (277 to 415VLL). AV6, MV6: 120/230VLL; 6A; Un: 57.7 to 144VLN (100 to 230VLL).	Energies	EEE indication when the value being measured is exceeding the "Continuous inputs overload" (maximum measurement capacity)
Accuracy (Display + RS485) (@25°C ±5°C, R.H. ≤60%, 50Hz)	In: see below, Un: see below	Overload status	Max. instantaneous variables: 999; energies: 9 999 999. Min. instantaneous variables: 0; energies 0.00.
Current AV5, AV6 models	From 0.002In to 0.2In: ±(0.5% RDG +3DGT). From 0.2In to Imax: ±(0.5% RDG +1DGT).	Max. and Min. indication	
Current MV5, MV6 models	From 0.002In to 0.2In: ±(1% RDG +3DGT). From 0.2In to Imax: ±(0.5% RDG +1DGT).	LEDs	
Phase-neutral voltage	In the range Un: ±(0,5% RDG +1DGT).	Red LED (energy consumption) AV5, AV6	0.001 kWh by pulse if CT ratio x VT ratio is <7; 0.01 kWh by pulse if CT ratio x VT ratio is ≥ 7.0 < 70.0; 0.1 kWh by pulse if CT ratio x VT ratio is ≥ 70.0 < 700.0; 1 kWh by pulse if CT ratio x VT ratio is ≥ 700.0.
Phase-phase voltage	In the range Un: ±(1% RDG +1DGT).	Red LED (energy consumption) MV5, MV6	0.001kWh/pulse if VT ratio by In < 35.0 0.01kWh/pulse if VT ratio by In ≥35.0 and <350.0 0.1kWh/pulse if VT ratio by In ≥ 350.0 and <3500.0 1kWh/pulse if VT ratio by In ≥ 3500.0
Frequency	Range: 45 to 65Hz; resolution: ±1Hz	Max frequency	16Hz, according to EN50470-3. Green LED (on the terminal blocks side) for power on (steady) and communication status: RX-TX (in case of RS485 option only) blinking.
Active power	±(1%RDG +2DGT).	Measurements	See "List of the variables that can be connected to:"
Power factor	±[0.001+1%(1.000 - "PF RDG")].	Method	TRMS measurements of distorted wave forms.
Reactive power	±(2%RDG +2DGT).	Coupling type	By means of external CT's.
Active energy	class B according to EN50470-1-3; class 1 according to EN62053-21.	Crest factor	AV5, AV6: ≤3 (15A max. peak). MV5, MV6: 1.414 @ Imax (Imax=1.2 In = 0.4V). In any case: Vpeak max = 0.565V.
Reactive energy	class 2 according to EN62053-23.		
Start up current:	10mA.		
Energy additional errors			
Influence quantities	According to EN62053-21, EN50470-1-3, EN62053-23		
Temperature drift	≤200ppm/°C.		
Sampling rate	1600 samples/s @ 50Hz, 1900 samples/s @ 60Hz		

Input specification (cont.)

Current Overloads Continuous For 500ms	1.2In, @ 50Hz. 20In, @ 50Hz.	Frequency	45 to 65 Hz.
Voltage Overloads Continuous For 500ms	1.2 Un 2 Un	Keypad	Two push buttons for variable selection and programming of the instrument working parameters.
Current input impedance AV5, AV6 MV5, MV6	< 0.3VA >100 kΩ		
Voltage input impedance Self-power supply	Power consumption: < 2VA		

Output specifications

Pulse output Number of outputs Type	1 Programmable from 0.01 to 9.99 kWh per pulses. Output connectable to the energy meter (+kWh)	Connections	2-wire max. distance 1000m, termination directly on the instrument.
Pulse duration	TOFF ≥120ms, according to EN62052-31. TON selectable (30 ms or 100 ms) according to EN62053-31	Addresses	247, selectable by means of the front keypad
Output Load	Static: opto-mosfet. VON 2.5 VAC/DC, 70 mA max. VOFF 260 VAC/DC max.	Protocol Data (bidirectional) Dynamic (reading only)	MODBUS/JBUS (RTU)
Insulation	By means of optocouplers, 4000 VRMS output to measuring inputs.	Static (reading and writing)	System and phase variables: see table "List of variables..." All the configuration parameters.
RS485 Type	Multidrop, bidirectional (static and dynamic variables)	Data format	1 start bit, 8 data bit, and even parity, 1 or 2 stop bit.
		Baud-rate	9.6, 19.2, 38.4, 57.6, 115.2 kbps.
		Driver input capability	1/5 unit load. Maximum 160 transceiver on the same bus.
		Insulation	By means of optocouplers, 4000 VRMS output to measuring input.

Software functions

Password	Numeric code of max. 3 DGT; 2 protection levels of the programming data:	Transformer ratio	1.0 to 99.9 / 100 to 999
1st level	Password "0", no protection;	VT (PT) ratio	1.0 to 99.9 / 100 to 999
2nd level	Password from 1 to 999, all data are protected	CT (AV5, AV6)	The max CTxVT product for AV5 models is 1187 (X option), for AV6 models is 2421 (X option). Primary current 10 to 10000.
Programming lock	By means of potentiometer (back-side of the display module) it is possible to lock the access to all the configuration parameters.	Displaying	Up to 3 variables per page. 6 different set of variables available.
System selection		Reset	By means of the front keypad: total energies (kWh, kvarh).
System 3-Ph.n unbalanced load	3-phase (4-wire) 3-phase (3-wire) without neutral connection.	Easy connection function	Wrong phase detection and displaying. For all the display selections (except "D" and "E") the current, power and energy measurement are independent on the current direction.
System 3-Ph.1 balanced load	<ul style="list-style-type: none"> 3-phase (3-wire) one current and 3-phase to phase voltage measurements. 3-phase (4-wire) one current and 3-phase to neutral voltage measurements. 		
System 2-Ph	2-phase (3-wire)		
System 1-Ph	1-phase (2-wire)		

General specifications

Operating temperature	-25°C to +55°C (-13°F to 131°F) (R.H. from 0 to 90% non-condensing) according to EN62053-21 and EN62053-23.	Surge	80Mhz On current and voltage measuring inputs circuit: 6kV;
Storage temperature	-30°C to +70°C (-22°F to 158°F) (R.H. < 90% non-condensing) according to EN62053-21 and EN62053-23)	Radio frequency suppression	According to CISPR 22
Overvoltage category	Cat. III	Standard compliance	
Insulation (for 1 minute)	4000 VRMS between measuring inputs and digital output.	Safety	EC60664, IEC61010-1 EN60664, EN61010-1 EN62052-11
Dielectric strength	4000VAC RMS for 1 minute	Metrology	EN62053-21, EN62053-23, EN50470-3
Noise rejection CMRR	100 dB, 48 to 62 Hz	Pulse output Approvals	DIN43864, IEC62053-31 CE, cULus listed (only AV)
EMC		Connections	Screw type 2.4 x 3.5 mm Min./Max. screws tightening torque: 0.4 Nm / 0.8 Nm
Electrostatic discharges	According to EN62052-11 15kV air discharge.	Housing	
Immunity to irradiated electromagnetic fields	Test with current: 10V/m from 80 to 2000MHz Test without any current: 30V/m from 80 to 2000MHz;	Dimensions (WxHxD)	72 x 72 x 65 mm
Burst	On current and voltage measuring inputs circuit: 4kV	Material	Noryl, PA66 self-extinguishing: UL 94 V-0 Panel and DIN-rail
Immunity to conducted disturbances	10V/m from 150kHz to	Mounting	
		Protection degree	
		Front	IP40
		Screw terminals	IP20
		Weight	Approx. 400g (packing included)



Power supply specifications

Self power supply

40 to 480VAC (45-65Hz).
Across input "VL2" and
"VL3"

Power consumption

≤2VA/1W

Accuracy AV5, AV6 (According to EN50470-3 and EN62053-23)

kWh, accuracy (RDG) depending on the current

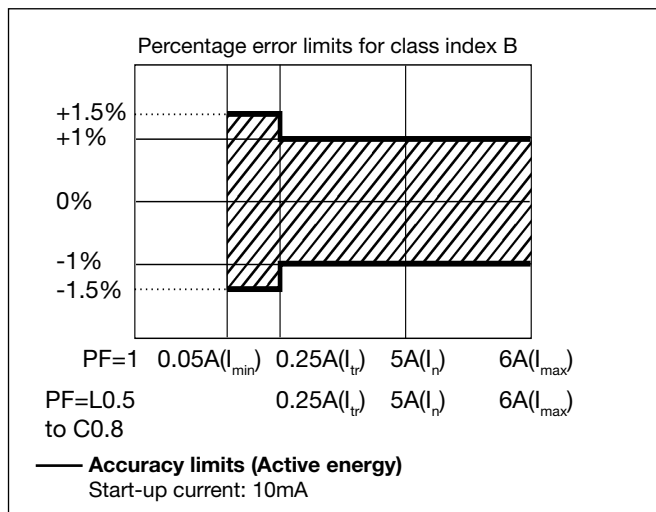

kvarh, accuracy (RDG) depending on the current

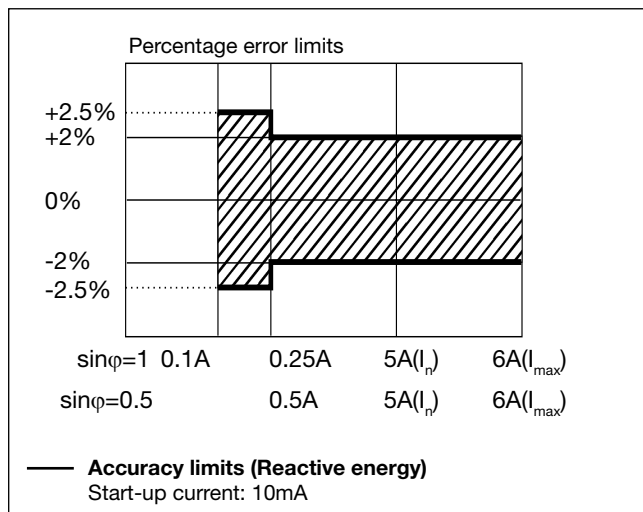

Accuracy MV5, MV6 (According to EN50470-3 and EN62053-23)

kWh, accuracy (RDG) depending on the current

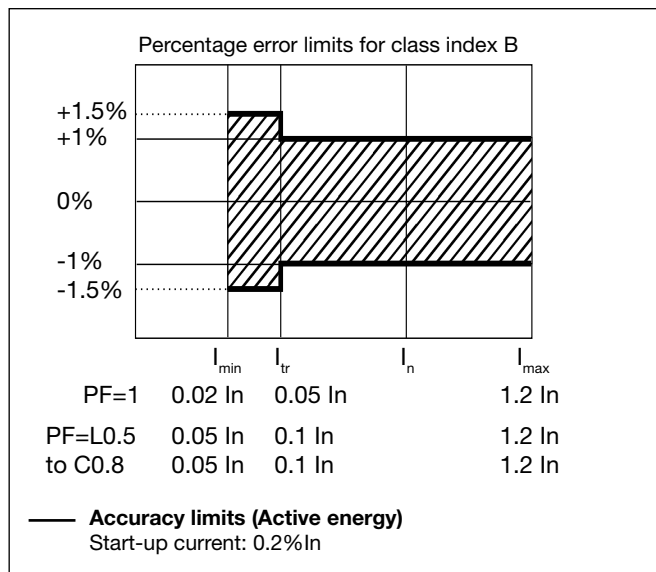

kvarh, accuracy (RDG) depending on the current

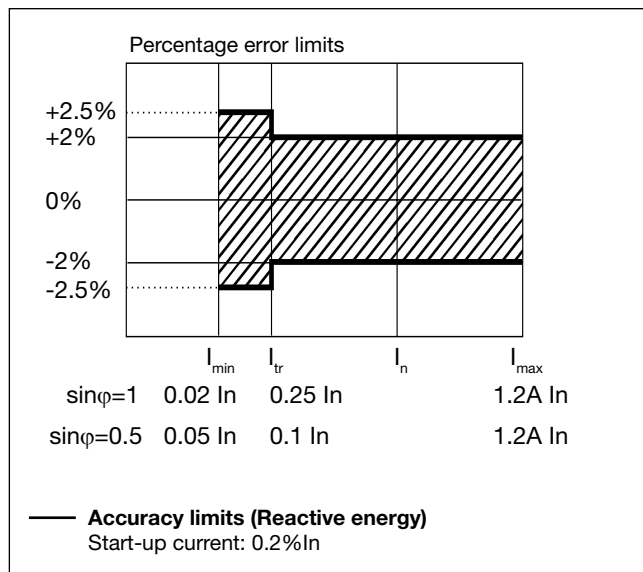

Insulation between inputs and outputs

	Measuring input	Opto-Mosfet output	Communication port	Self power supply
Measuring inputs	-	4kV	4kV	0kV
Opto-Mosfet output	4kV	-	-	4kV
Communication port	4kV	-	-	4kV
Self power supply	0kV	4kV	4kV	-

NOTE: all the models have, mandatorily, to be connected to external current transformers.

Used calculation formulas

Phase variables

Instantaneous effective voltage

$$V_{1N} = \sqrt{\frac{1}{n} \cdot \sum_1^n (V_{1N})_i^2}$$

Instantaneous active power

$$W_1 = \frac{1}{n} \cdot \sum_1^n (V_{1N})_i \cdot (A_1)_i$$

Instantaneous power factor

$$\cos\varphi_1 = \frac{W_1}{VA_1}$$

Instantaneous effective current

$$A_1 = \sqrt{\frac{1}{n} \cdot \sum_1^n (A_1)_i^2}$$

Instantaneous apparent power

$$VA_1 = V_{1N} \cdot A_1$$

Instantaneous reactive power

$$\text{var}_1 = \sqrt{(VA_1)^2 - (W_1)^2}$$

System variables

Equivalent three-phase voltage

$$V_\Sigma = \frac{V_1 + V_2 + V_3}{3} \cdot \sqrt{3}$$

Voltage asymmetry

Three-phase active power

$$W_\Sigma = W_1 + W_2 + W_3$$

Three-phase apparent power

$$VA_\Sigma = \sqrt{W_\Sigma^2 + \text{var}_\Sigma^2}$$

Three-phase power factor

$$\cos\varphi_\Sigma = \frac{W_\Sigma}{VA_\Sigma}$$

Energy metering

$$k \text{ var hi} = \int_{t_1}^{t_2} Qi(t) dt \cong \Delta t \sum_{n1}^{n2} Qnj$$

$$kWhi = \int_{t_1}^{t_2} Pi(t) dt \cong \Delta t \sum_{n1}^{n2} Pnj$$

Where:

i= considered phase (L1, L2 or L3)
P= active power; **Q**= reactive power;
t1, t2=starting and ending time points of consumption recording; **n**= time unit; Δt = time interval between two successive power consumptions;
n1, n2= starting and ending discrete time points of consumption recording

List of the variables that can be connected to:

- RS485 communication port
- Pulse outputs (only “energies”)

N°	Variable	1-ph. sys.	2-ph. sys.	3-ph. 4-wire balanced system	3-ph. 4-wire unbalanced system	3-ph. 3-wire balanced system	3-ph. 3-wire unbalanced system	Notes
1	kWh	x	x	x	x	x	x	Total (2)
2	kvarh	x	x	x	x	x	x	Total (3)
3	V L-N sys (1)	o	x	x	x	x	x	sys=system (Σ)
4	V L1	x	x	x	x	x	x	
5	V L2	o	x	x	x	x	x	
6	V L3	o	o	x	x	x	x	
7	V L-L sys (1)	o	x	x	x	x	x	sys=system (Σ)
8	V L1-2	o	x	x	x	x	x	
9	V L2-3	o	o	x	x	x	x	
10	V L3-1	o	o	x	x	x	x	
11	A L1	x	x	x	x	x	x	
12	A L2	o	x	x	x	x	x	
13	A L3	o	o	x	x	x	x	
14	VA sys (1)	x	x	x	x	x	x	sys=system (Σ)
15	VA L1 (1)	x	x	x	x	x	x	
16	VA L2 (1)	o	x	x	x	x	x	
17	VA L3 (1)	o	o	x	x	x	x	
18	var sys	x	x	x	x	x	x	sys=system (Σ)
19	var L1 (1)	x	x	x	x	x	x	
20	var L2 (1)	o	x	x	x	x	x	
21	var L3 (1)	o	o	x	x	x	x	
22	W sys	x	x	x	x	x	x	sys=system (Σ)
23	W L1 (1)	x	x	x	x	x	x	
24	W L2 (1)	o	x	x	x	x	x	
25	W L3 (1)	o	o	x	x	x	x	
26	PF sys	x	x	x	x	x	x	sys=system (Σ)
27	PF L1	x	x	x	x	x	x	
28	PF L2	o	x	x	x	x	x	
29	PF L3	o	o	x	x	x	x	
30	Hz	x	x	x	x	x	x	
31	Phase sequence	o	o	x	x	x	x	
32	THD VL1N	X	X	X	X	O	O	only if THD enabled
33	THD VL2N	O	X	X	X	O	O	only if THD enabled
34	THD VL3N	O	O	X	X	O	O	only if THD enabled
35	THD A L1	X	X	X	X	X	X	only if THD enabled
36	THD A L2	O	X	X	X	X	X	only if THD enabled
37	THD A L3	O	O	X	X	X	X	only if THD enabled
38	THD V L1-2	O	X	X	X	X	X	only if THD enabled
39	THD V L2-3	O	O	X	X	X	X	only if THD enabled
40	THD V L3-1	O	O	X	X	X	X	only if THD enabled
41	A n	O	X	O	X	O	O	

(x) = available

(o) = not available (zero indication on the display)

(1) = Variable available only through the serial communication port RS485

(2) = also kWh- (exported) with application E (see next table)

(3) = sum (not algebraic) of kvarh imported and exported with application F (see next table)

Display pages

No	1st variable (1st half-line)	2nd variable (2nd half-line)	3rd variable (2nd line)	Note	Applications					
					A	B	C	D	E	F
	Phase sequence			The phase sequence triangle appears in any page only if there is a phase reverse	x	x	x	x	x	x
1	Total kWh		W sys		x	x	x	x	x	x
1b	Total kWh (-)		"NEG"	Exported active energy					+	
2	Total kvarh		kvar sys			+	+	+	+	T
3		PF sys	Hz	Indication of C, -C, L, -L depending on the quadrant		x	x	x	x	x
4	PF L1	PF L2	PF L3	Indication of C, -C, L, -L depending on the quadrant			x	x	x	x
5	A L1	A L2	A L3				x	x	x	x
6	V L1-2	V L2-3	V L3-1				x	x	x	
7	V L1	V L2	V L3				x	x		
8	"thd"	"L1"	THD VL1-N			x	x	x	x	x
9	"thd"	"L2"	THD VL2-N			x	x	x	x	x
10	"thd"	"L3"	THD VL3-N			x	x	x	x	x
11	"thd"	"L1"	THD A L1			x	x	x	x	x
12	"thd"	"L2"	THD A L2			x	x	x	x	x
13	"thd"	"L3"	THD A L3			x	x	x	x	x
14	"thd"	"L1"	THD VL1-2			x	x	x	x	x
15	"thd"	"L2"	THD VL2-3			x	x	x	x	x
16	"thd"	"L3"	THD VL3-1			x	x	x	x	x
17	"A n"		A n			x	x	x	x	x
18	"working hours"(rel. to kWh+)		h				x	x	x	x
19	"working hours"(re. to kWh-)		h-						x	

Notes: x = available

+ = only positive kvarh is measured (kvar sys is the algebraic sum of the phase kvar)

T = positive and negative kvarh are summed and measured in the same kvarh meter

(kvarsys is the sum of the absolute values of each phase kvar). The phase kvar are displayed with the correct sign.

Additional available information on the display

Type	1st line	2nd line	Note
Meter information 1	Y. 2007	r.A0	Year of production and firmware release
Meter information 2	value	LEd (kWh)	KWh per pulse of the LED
Meter information 3	SYS [3P.n]	value	System type and connection type
Meter information 4	Ct rAt.	value	Current transformer ratio
Meter information 5	Ut rAt.	value	Voltage transformer ratio
Meter information 6	PuLSE (kWh)	value	Pulse output: kWh per pulse
Meter information 7	Add	value	Serial communication address
Meter information 8	value	Sn	Secondary address (M-bus protocol)

List of selectable applications

	Description	Notes
A	Active energy meter	Active energy measurement with some minor parameters
B	Active and reactive energy meter	Active and reactive energy measurement with some minor parameters
C	Full set of variables	Full set of available variables can be displayed (default selection)
D	Full set of variables +	Full set of available variables can be displayed +
E	Full set of variables +	Full set of variables with exported (negative) kWh meter
F	Full set of variables	Full set of variables with imported and exported kWh meters

Notes:

+ Only in "D" and "E" applications the actual direction of the current is considered.

One instrument with double mounting capability

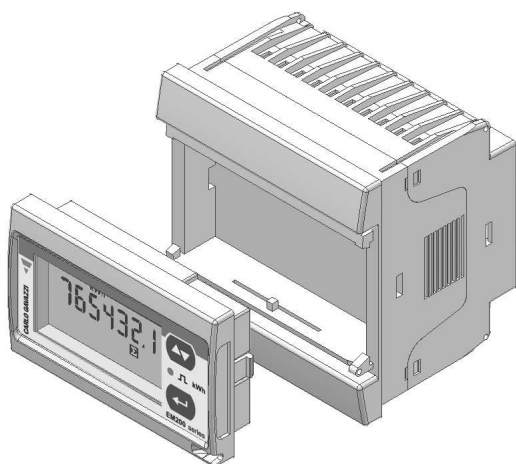

... as DIN-rail mounting meter.

By means of the patented detachable display it is possible to configure the same instrument either as a panel mounting meter or...

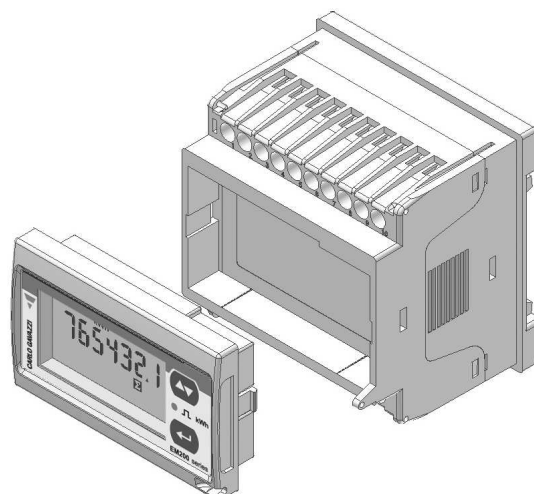

Wiring diagrams

(6A) Self power supply, system type selection: 3P.n

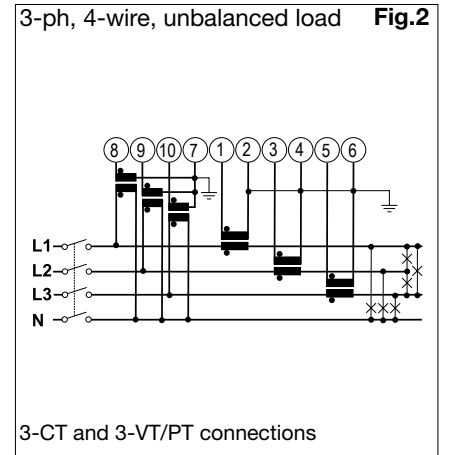
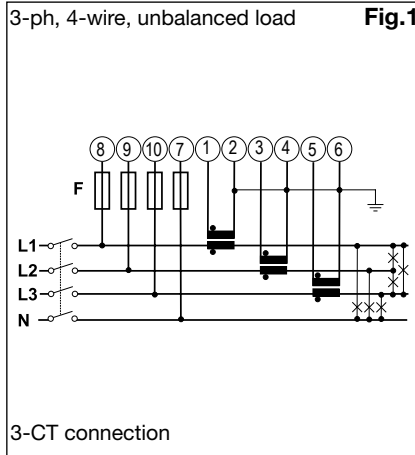
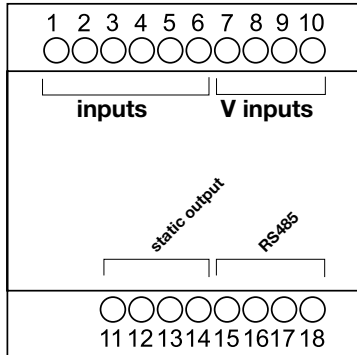

(6A) System type selection: 3P

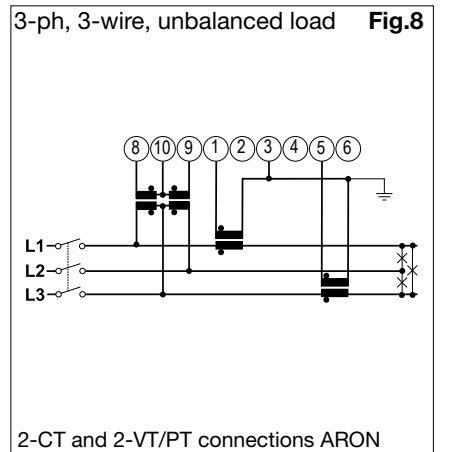
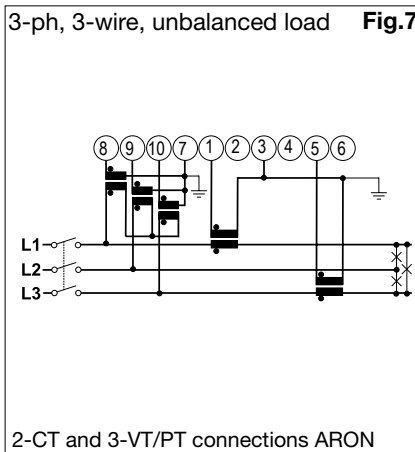
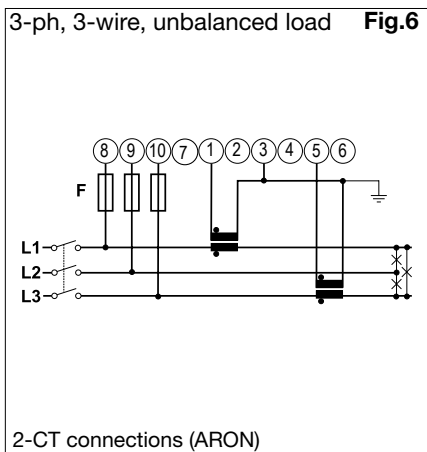
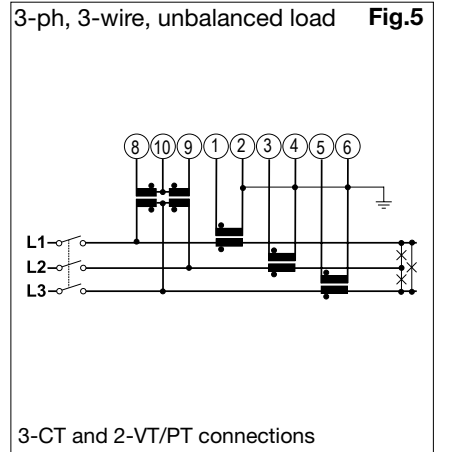
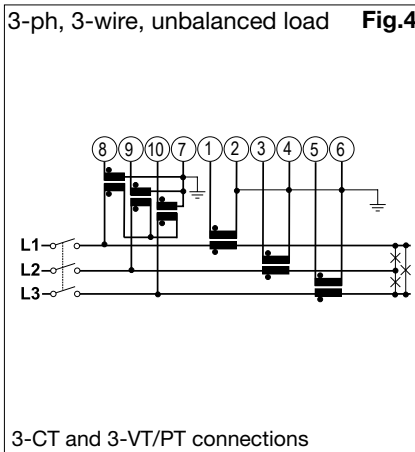
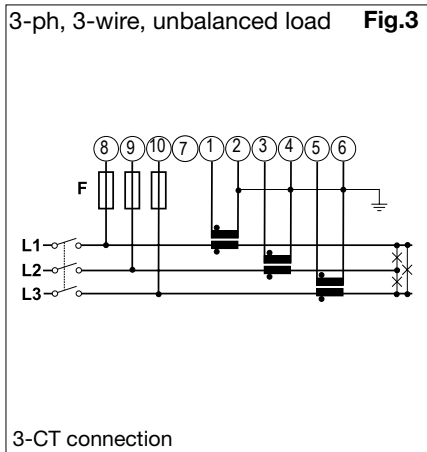

Wiring diagrams

(6A) Self power supply, system type selection: 3P.1

3-ph, 3/4-wire, balanced load **Fig.9**
1-CT connection

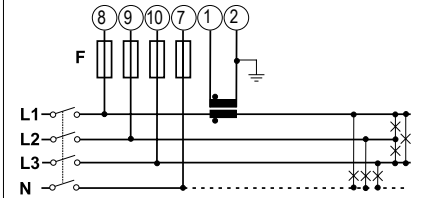

N connection is optional.
NOTE: in the calculations, it is considered only the voltage relevant to L1

3-ph, 3-wire, balanced load **Fig.10**

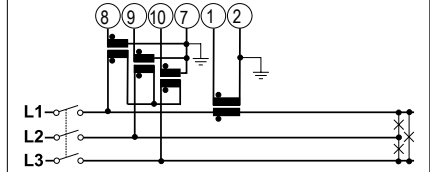

1-CT and 3-VT/PT connections

3-ph, 3-wire, balanced load **Fig.11**

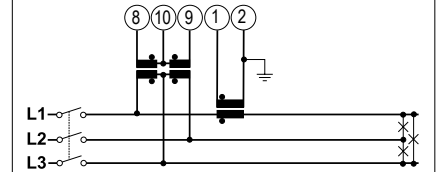

1-CT and 2-VT/PT connections

(6A) System type selection: 2P

2-ph, 3-wire **Fig.12**

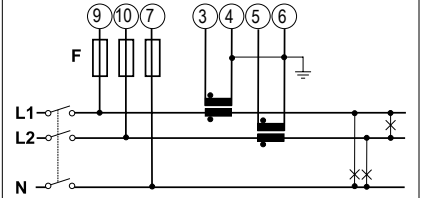

2-CT connection

2-ph, 3-wire **Fig.13**

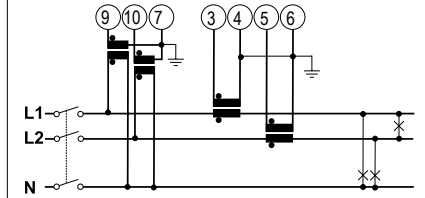

2-CT and 2-VT/PT connections

(6A) System type selection: 1P

1-ph, 2-wire **Fig.14**

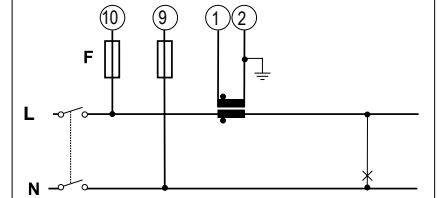

1-CT connection

(6A) System type selection: 1P

1-ph, 2-wire **Fig.15**

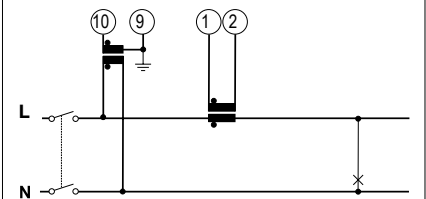

1-CT and 1-VT connections

Static output wiring diagram

Opto-mosfet

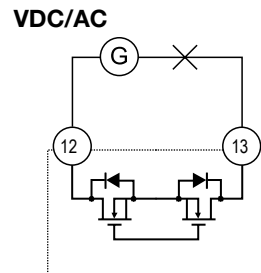

VDC/AC supply

RS485 port wiring diagram

RS485 port

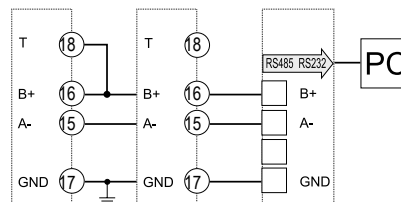

RS485 NOTE: additional devices provided with RS485 are connected as per the picture above. The termination of the serial output is carried out only on the last instrument of the network, by means of a jumper between (B+) and (T).

Front panel description

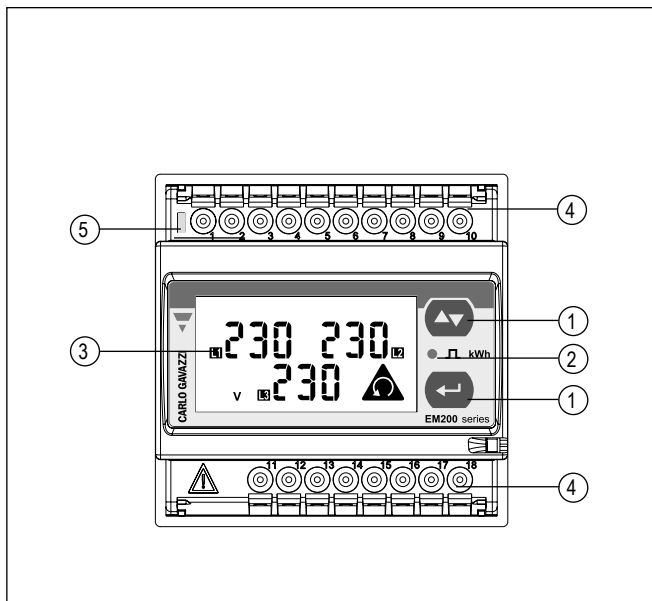

1. **Keypad**
To program the configuration parameters and scroll the variables on the display.
2. **Pulse output LED**
Red LED blinking proportional to the energy being measured.
3. **Display**
LCD-type with alphanumeric indications to display all the measured variables.
4. **Connections**
Screw terminal blocks for instrument wiring.
5. **Green LED**
Lit when power supply is available.

Dimensions (DIN configuration)

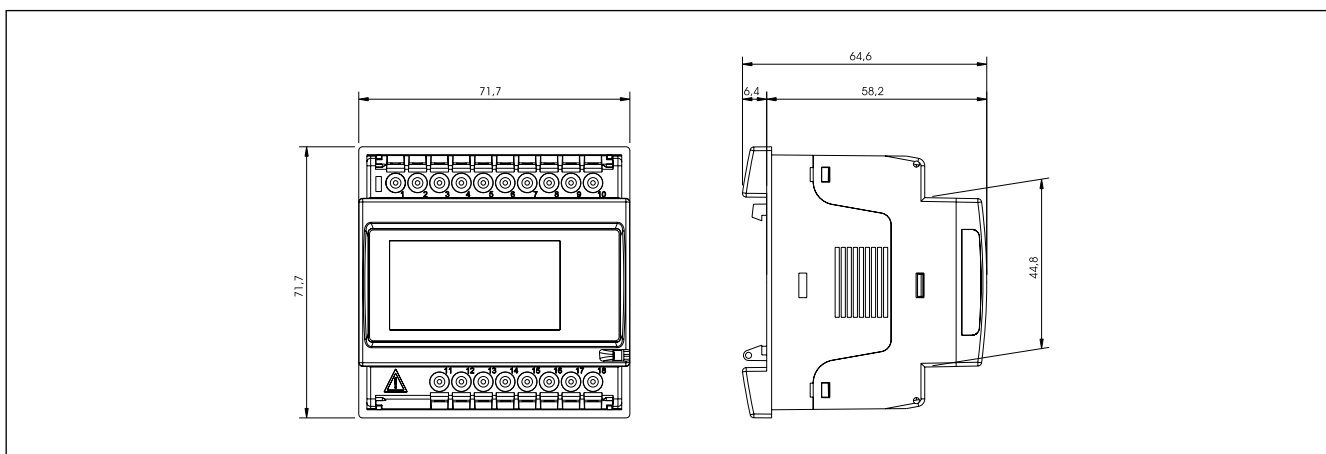

Dimensions and panel cut out (72x72 panel mounting configuration)

