



Chipsmall Limited consists of a professional team with an average of over 10 year of expertise in the distribution of electronic components. Based in Hongkong, we have already established firm and mutual-benefit business relationships with customers from,Europe,America and south Asia,supplying obsolete and hard-to-find components to meet their specific needs.

With the principle of "Quality Parts,Customers Priority,Honest Operation,and Considerate Service",our business mainly focus on the distribution of electronic components. Line cards we deal with include Microchip,ALPS,ROHM,Xilinx,Pulse,ON,Everlight and Freescale. Main products comprise IC,Modules,Potentiometer,IC Socket,Relay,Connector.Our parts cover such applications as commercial,industrial, and automotives areas.

We are looking forward to setting up business relationship with you and hope to provide you with the best service and solution. Let us make a better world for our industry!



Contact us

Tel: +86-755-8981 8866 Fax: +86-755-8427 6832

Email & Skype: info@chipsmall.com Web: www.chipsmall.com

Address: A1208, Overseas Decoration Building, #122 Zhenhua RD., Futian, Shenzhen, China



Fan Control Device with High Frequency PWM and Temperature Monitors

PRODUCT FEATURES

Datasheet

- 3.3 Volt Operation (5 Volt Tolerant Input Buffers)
- SMBus 2.0 Compliant Interface (Fixed, not Discoverable) with Three Slave Address Options
- Fan Control
 - PWM (Pulse width Modulation) Outputs (3)
 - Fan Tachometer Inputs (4)
 - Programmable automatic fan control based on temperature
 - Backwards compatible with fans requiring lower frequency PWM drive
 - High frequency fan support for 4 wire fans
 - One fan can be controlled from as many as 3 temperature zones
 - Fan ramp rate control for acoustic noise reduction
- Power Savings Modes
 - Two monitoring modes: continuous or cycling (for power savings)
 - Two low power modes when monitoring is off: Sleep and Shutdown
- Temperature Monitor
 - Monitoring of Two Remote Thermal Diodes (+/- 3 deg C accuracy)
 - Internal Ambient Temperature Measurement
 - Limit Comparison of all Monitored Values
 - Interrupt Pin for out-of-limit Temperature Indication
- Voltage Monitor
 - Monitors VCC and VCCP
 - Limit Comparison of all Monitored Values
 - Interrupt Pin for out-of-limit Voltage Indication
- XOR Tree Test Mode
- 16-Pin SSOP Lead-Free RoHS Compliant Package

ORDER NUMBERS:

EMC2300-AZC FOR 16 PIN, SSOP LEAD-FREE ROHS COMPLIANT PACKAGE

EMC2300-AZC-TR FOR 16 PIN, SSOP LEAD-FREE ROHS COMPLIANT PACKAGE (TAPE AND REEL)

2,800 UNITS FOR 13 INCH REEL, 97 UNITS PER TUBE



80 ARKAY DRIVE, HAUPPAUGE, NY 11788 (631) 435-6000, FAX (631) 273-3123

Copyright © 2008 SMSC or its subsidiaries. All rights reserved.

Circuit diagrams and other information relating to SMSC products are included as a means of illustrating typical applications. Consequently, complete information sufficient for construction purposes is not necessarily given. Although the information has been checked and is believed to be accurate, no responsibility is assumed for inaccuracies. SMSC reserves the right to make changes to specifications and product descriptions at any time without notice. Contact your local SMSC sales office to obtain the latest specifications before placing your product order. The provision of this information does not convey to the purchaser of the described semiconductor devices any licenses under any patent rights or other intellectual property rights of SMSC or others. All sales are expressly conditional on your agreement to the terms and conditions of the most recently dated version of SMSC's standard Terms of Sale Agreement dated before the date of your order (the "Terms of Sale Agreement"). The product may contain design defects or errors known as anomalies which may cause the product's functions to deviate from published specifications. Anomaly sheets are available upon request. SMSC products are not designed, intended, authorized or warranted for use in any life support or other application where product failure could cause or contribute to personal injury or severe property damage. Any and all such uses without prior written approval of an Officer of SMSC and further testing and/or modification will be fully at the risk of the customer. Copies of this document or other SMSC literature, as well as the Terms of Sale Agreement, may be obtained by visiting SMSC's website at <http://www.smisc.com>. SMSC is a registered trademark of Standard Microsystems Corporation ("SMSC"). Product names and company names are the trademarks of their respective holders.

SMSC DISCLAIMS AND EXCLUDES ANY AND ALL WARRANTIES, INCLUDING WITHOUT LIMITATION ANY AND ALL IMPLIED WARRANTIES OF MERCHANTABILITY, FITNESS FOR A PARTICULAR PURPOSE, TITLE, AND AGAINST INFRINGEMENT AND THE LIKE, AND ANY AND ALL WARRANTIES ARISING FROM ANY COURSE OF DEALING OR USAGE OF TRADE. IN NO EVENT SHALL SMSC BE LIABLE FOR ANY DIRECT, INCIDENTAL, INDIRECT, SPECIAL, PUNITIVE, OR CONSEQUENTIAL DAMAGES; OR FOR LOST DATA, PROFITS, SAVINGS OR REVENUES OF ANY KIND; REGARDLESS OF THE FORM OF ACTION, WHETHER BASED ON CONTRACT; TORT; NEGLIGENCE OF SMSC OR OTHERS; STRICT LIABILITY; BREACH OF WARRANTY; OR OTHERWISE; WHETHER OR NOT ANY REMEDY OF BUYER IS HELD TO HAVE FAILED OF ITS ESSENTIAL PURPOSE, AND WHETHER OR NOT SMSC HAS BEEN ADVISED OF THE POSSIBILITY OF SUCH DAMAGES.

Table of Contents

Chapter 1	General Description	8
Chapter 2	Pinout	9
2.1	EMC2300 Pinout	9
Chapter 3	Pin Description	10
3.1	Pin Functions for EMC2300	10
3.2	Buffer Type Description	11
3.3	3.3V Operation, 5V Tolerance	11
Chapter 4	Operational Description	12
4.1	Maximum Guaranteed Ratings	12
4.2	Ratings for Operation	12
Chapter 5	SMBus Interface	15
5.1	Slave Address	15
5.2	Slave Bus Interface	16
5.3	Bus Protocols	16
5.4	Invalid Protocol Response Behavior	17
5.4.1	Undefined Registers	17
5.5	General Call Address Response	17
5.6	Slave Device Time-Out	18
5.7	Stretching the SCLK Signal	18
5.8	SMBus Timing	18
5.9	Bus Reset Sequence	18
5.10	SMBus Alert Response Address	18
Chapter 6	Hardware Monitoring	20
6.1	Input Monitoring	20
6.2	Resetting the EMC2300	20
6.2.1	Power-On Reset	20
6.2.2	Soft Reset (Initialization)	20
6.3	Monitoring Modes	20
6.3.1	Continuous Monitoring Mode	22
6.3.2	Cycle Monitoring Mode	22
6.4	Interrupt Status Registers	23
6.4.1	Diode Fault	24
6.5	Interrupt Pin	25
6.6	Low Power Modes	26
6.6.1	Sleep Mode	26
6.6.2	Shutdown Mode	26
6.7	Analog Voltage Measurement	26
6.8	Temperature Measurement	27
6.8.1	Internal Temperature Measurement	27
6.8.2	External Temperature Measurement	27
6.8.3	Temperature Data Format	28
6.9	Thermal Zones	28
Chapter 7	Fan Control	29
7.1	General Description	29
7.1.1	Limit and Configuration Registers	29

7.1.2	Device Set-Up	29
7.1.3	PWM Fan Speed Control	30
7.1.4	Fan Speed Monitoring	38
7.1.5	Linking Fan Tachometers to PWMs	44
<hr/>		
Chapter 8	Register Set	45
8.1	Undefined Registers	49
8.2	Defined Registers	49
8.2.1	Registers 20-24h: Voltage Reading	49
8.2.2	Registers 25-27h: Temperature Reading	49
8.2.3	Registers 28-2Fh: Fan Tachometer Reading	50
8.2.4	Registers 30-32h: Current PWM Duty	51
8.2.5	Register 3Eh: Company ID	53
8.2.6	Register 3Fh: Version / Stepping	53
8.2.7	Register 40h: Ready/Lock/Start Monitoring	53
8.2.8	Register 41h: Interrupt Status Register 1	55
8.2.9	Register 42h: Interrupt Status Register 2	56
8.2.10	Registers 44-4Dh: Voltage Limit Registers	57
8.2.11	Registers 4E-53h: Temperature Limit Registers	58
8.2.12	Registers 54-5Bh: Fan Tachometer Low Limit	59
8.2.13	Registers 5C-5Eh: PWM Configuration	59
8.2.14	Registers 5F-61h: Zone Temperature Range, PWM Frequency	61
8.2.15	Register 62h, 63h: PWM Ramp Rate Control	63
8.2.16	Registers 64-66h: Minimum PWM Duty Cycle	64
8.2.17	Registers 67-69h: Zone Low Temperature Limit	65
8.2.18	Registers 6A-6Ch: Absolute Temperature Limit	65
8.2.19	Register 6F: XOR Test Register	66
8.2.20	Register 7Ch: Special Function Register	67
8.2.21	Register 7Eh: Interrupt Enable 1 Register	68
8.2.22	Register 7Fh: Configuration Register	68
8.2.23	Register 80h: Interrupt Enable 2 Register	69
8.2.24	Register 81h: TACH_PWM Association Register	70
8.2.25	Register 82h: Interrupt Enable 3 Register	71
8.2.26	Registers 85h-88h: A/D Converter LSbs Registers	72
8.2.27	Registers 90h-93h: TachX Option Registers	72
8.2.28	Registers 94h-96h: PWMx Option Registers	73
<hr/>		
Chapter 9	Timing Diagrams	75
9.1	PWM Outputs	75
9.2	SMBus Interface	76
<hr/>		
Chapter 10	Mechanical Specifications	77
10.1	Package Markings	78
<hr/>		
Appendix A	ADC Voltage Conversion	79
<hr/>		
Appendix B	Example Fan Circuits	80

Datasheet

List of Figures

Figure 2.1	EMC2300 16 Pin SSOP Pinout	9
Figure 5.1	Address Selection on EMC2300	16
Figure 6.1	Interrupt Control	24
Figure 7.1	Automatic Fan Control Flow Diagram	32
Figure 7.2	Automatic Fan Control	34
Figure 7.3	Spin Up Reduction Enabled	35
Figure 7.4	Illustration of PWM Ramp Rate Control	37
Figure 7.5	PWM and Tachometer Concept	40
Figure 8.1	Fan Activity Above Low Temp Limit	61
Figure 9.1	PWMx Output Timing	75
Figure 9.2	SMBus Timing	76
Figure 10.1	16 Pin SSOP Package Outline and Parameters	77
Figure B.1	Fan Drive Circuitry (Apply to PWM Driving Two Fans)	80
Figure B.2	Fan Drive Circuitry (Apply to PWM Driving One Fan)	81
Figure B.3	Fan Tachometer Circuitry (Apply to Each Fan)	81
Figure B.4	Remote Diode (Apply to Remote2 Lines)	82
Figure B.5	Suggested Minimum Track Width and Spacing	82

List of Tables

Table 3.1	Pin Description	10
Table 3.2	Buffer Type Descriptions	11
Table 5.1	SMBus Slave Address Options	15
Table 5.2	SMBus Write Byte Protocol	17
Table 5.3	SMBus Read Byte Protocol	17
Table 5.4	Modified SMBus Receive Byte Protocol Response to ARA	18
Table 6.1	AVG[2:0] Bit Decoder	21
Table 6.2	Conversion Cycle Timing	21
Table 6.3	ADC Conversion Sequence	22
Table 6.4	Low Power Mode Control Bits	26
Table 6.5	Min/Max ADC Conversion Table	27
Table 6.6	Temperature Data Format	28
Table 7.1	PWM Ramp Rate	37
Table 7.2	Minimum RPM Detectable Using 3 Edges	42
Table 7.3	Minimum RPM Detectable Using 2 Edges	43
Table 8.1	Register Summary	45
Table 8.2	Registers 20-24h: Voltage Reading	49
Table 8.3	Voltage vs. Register Reading	49
Table 8.4	Registers 25-27h: Temperature Reading	49
Table 8.5	Temperature vs. Register Reading	50
Table 8.6	Registers 28-2Fh: Fan Tachometer Reading	50
Table 8.7	Registers 30-32h: Current PWM Duty	51
Table 8.8	PWM Duty vs Register Reading	52
Table 8.9	Register 3Eh: Company ID	53
Table 8.10	Register 3Fh: Version / Stepping	53
Table 8.11	Register 40h: Ready/Lock/Start Monitoring	53
Table 8.12	Ready/Lock/Start Monitoring	54
Table 8.13	Register 41h: Interrupt Status Register 1	55
Table 8.15	Register 42h: Interrupt Status Register 2	56
Table 8.17	Registers 44-4Dh: Voltage Limit Registers	57
Table 8.19	Registers 4E-53h: Temperature Limit Registers	58
Table 8.20	Temperature Limits vs. Register Settings	58
Table 8.21	Registers 54-5Bh: Fan Tachometer Low Limit	59
Table 8.22	Registers 5C-5Eh: PWM Configuration	59
Table 8.23	Fan Zone Setting	60
Table 8.24	Fan Spin-Up Register	61
Table 8.25	Registers 5F-61h: Zone Temperature Range, PWM Frequency	61
Table 8.26	Register Setting vs. PWM Frequency	62
Table 8.27	Register Setting vs. Temperature Range	62
Table 8.28	Register 62h, 63h: Min/Off, PWM Ramp Rate Control	63
Table 8.29	PWM Ramp Rate Control	64
Table 8.30	Registers 64-66h: Minimum PWM Duty Cycle	64
Table 8.31	PWM Duty vs. Register Setting	64
Table 8.32	Registers 67-69h: Zone Low Temperature Limit	65
Table 8.33	Temperature Limit vs. Register Setting	65
Table 8.34	Registers 6A-6Ch: Absolute Temperature Limit	65
Table 8.35	Absolute Limit vs. Register Setting	66
Table 8.36	Register 6F: XOR Test Register	66
Table 8.37	Register 7Ch: Special Function Register	67
Table 8.39	AVG[2:0] Bit Decoder	67
Table 8.40	Register 7Eh: Interrupt Enable 1 Register	68
Table 8.42	Register 7Fh: Configuration Register	68



Datasheet

Table 8.44 Register 80h: Interrupt Enable 2 Register	69
Table 8.46 Register 81h: TACH_PWM Association Register	70
Table 8.49 Register 82h: Interrupt Enable 3 Register	71
Table 8.51 Registers 85h-88h: A/D Converter LSbs Registers	72
Table 8.53 Registers 94h-96h: PWMx Option Registers	73
Table 9.1 Timing for PWM[1:3] Outputs	75
Table 9.2 SMBus Timing	76
Table A.1 Analog-to-Digital Voltage Conversions for Hardware Monitoring Block.	79

Chapter 1 General Description

The EMC2300 is an environmental monitoring device with automatic fan control capability. This ACPI compliant device provides hardware monitoring for up to two voltages and three thermal zones, measures the speed of up to four fans, and controls the speed of multiple DC fans using Pulse Width Modulator (PWM) outputs. High frequency and low frequency PWMs are supported.

The EMC2300 hardware monitor provides analog inputs for monitoring the processor voltage V_{ccp}. This device has the capability to monitor its own internal VCC power supply, which may be connected to either main power (VCC) or the suspend power well (VTR).

The EMC2300 hardware monitor includes support for monitoring three thermal zones: two external and one internal. The external temperatures are measured via thermal diode inputs capable of monitoring remote devices. In addition, the EMC2300 is equipped with an ambient temperature sensor for measuring the internal temperature.

Pulse Width Modulators (PWM) control the speed of the fans by varying the output duty cycle of the PWM. Each PWM can be associated with any or all of the thermal zones monitored. As the temperature of the associated zone varies, the PWM duty cycle is adjusted accordingly. The Ramp Rate Control feature controls the rate of change of the PWM output, thereby reducing system noise created by changing the fan speed. The speed of each fan is monitored by a Fan Tachometer input. The measured values are compared to values stored in Limit Registers to detect if a fan has stalled or seized.

Fan speed may be under host software control or automatic. In host control mode, the host software continuously monitors temperature and fan speed registers, makes decisions as to desired fan speed and sets the PWM's to drive the required fan speed. This device offers an interrupt output signal (INT#), which may be used to interrupt the host on out-of-limit temperature or voltage condition enabling an ACPI response as opposed to the host software continuously monitoring status. In auto "zone" mode, the logic continuously monitors the temperature and fan speeds and adjusts speeds without intervention from the host CPU. Fan speed is adjusted according to an algorithm using the temperature measured in the selected zone, the high and low limits set by the user, and the current fan speed.

The EMC2300 supports two Monitoring modes: Continuous Mode and Cycle Mode. In the continuous monitoring mode, the sampling and conversion process is performed continuously for each voltage and temperature reading after monitoring is enabled. The time for each voltage and temperature reading varies depending on the measurement option. In cycle monitoring mode, the part completes all sampling and conversions, then waits approximately one second to repeat the process. It repeats the sampling and conversion process typically every 1.2 seconds (1.4 sec max - default averaging enabled). The sampling and conversion of each voltage and temperature reading is performed once every monitoring cycle. (This is a power saving mode.)

The EMC2300 can be placed in one of two low-power modes: Sleep mode or Shutdown mode. These modes do not reset any of the registers of the device. In Sleep mode bias currents are on and the internal oscillator is on, but the A/D converter and monitoring cycle are turned off. Serial bus communication is still possible with any register in the Hardware Monitor Block while in this low-power mode. In Shutdown mode the bias currents are off, the internal oscillator is off, and the A/D converter and monitoring cycle are turned off. Serial communication is only possible with a select register.

Chapter 2 Pinout

The EMC2300 is offered in a 16 pin SSOP mechanical package.

2.1 EMC2300 Pinout

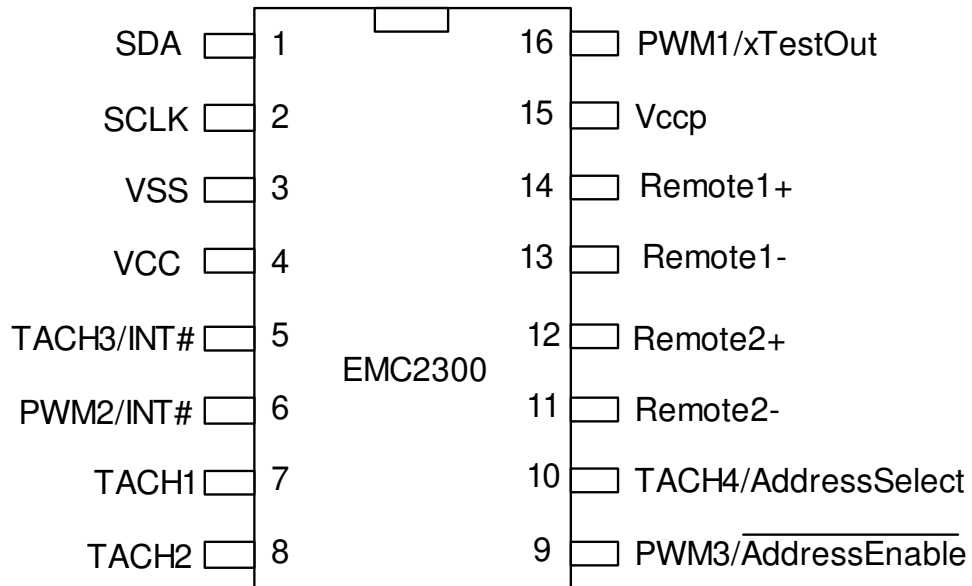

Figure 2.1 EMC2300 16 Pin SSOP Pinout

Chapter 3 Pin Description

3.1 Pin Functions for EMC2300

Table 3.1 Pin Description

PIN #	NAME	FUNCTION	BUFFER TYPE	BUFFER REQUIREMENT PER FUNCTION (Note 3.1)	POWER WELL	NOTES
HARDWARE MONITORING BLOCK (16)						
1	SDA	System Management Bus bi-directional Data. Open Drain output.	$I_{M}OD3$	$I_{M}OD3$	VCC	
2	SCLK	System Management Bus Clock.	I_M	I_M	VCC	
13	Remote1-	This is the negative Analog input (current sink) from the remote thermal diode. This serves as the negative input into the A/D. Digital Input.	I_{AN}	I_{AN}	VCC	
14	Remote1+	This is the positive input (current source) from the remote thermal diode. This serves as the positive input into the A/D.	I_{AN}	I_{AN}	VCC	
11	Remote2-	This is the negative Analog input (current sink) from the remote thermal diode. This serves as the negative input into the A/D. Digital Input.	I_{AN}	I_{AN}	VCC	
12	Remote2+	This is the positive input (current source) from the remote thermal diode. This serves as the positive input into the A/D.	I_{AN}	I_{AN}	VCC	
15	VCCP	Analog input for +Vccp (processor voltage: 0 to 3.0V).	I_{AN}	I_{AN}	VCC	Note 3.2
7	TACH1	Input for monitoring a fan tachometer input.	I_M	I_M	VCC	
8	TACH2	Input for monitoring a fan tachometer input.	I_M	I_M	VCC	
5	TACH3 /INT#	Input for monitoring a fan tachometer input. /Interrupt output to indicate a thermal and/or voltage event.	I_MOD3	$I_M /OD3$	VCC	
10	TACH4 /Address Select	Input for monitoring a fan tachometer input. If in Address Select Mode, determines the SMBus address of the device.	I_M	I_M	VCC	
16	PWM1 /xTest Out	PWM Output 1 controlling speed of fan. When in XOR tree test mode, functions as XOR Tree output.	O8	OD8/O8	VCC	
6	PWM2 /INT#	PWM Output 2 controlling speed of fan. /Interrupt output to indicate a thermal and/or voltage event.	OD8	OD8/OD8	VCC	
9	PWM3 /Address Enable#	PWM Output 3 controlling speed of fan. If pulled to ground at power on, enables Address Select Mode (Address Select pin controls SMBus address of the device).	IOD8	OD8/I	VCC	
4	VCC	Positive Power Supply. Nominal 3.3V. VCC is monitored by the Hardware Monitoring Block. (Can be powered by +3.3V Standby power if monitoring in low power states is required.)				
3	VSS	Analog Ground.				

Datasheet

Note: The “#” as the suffix of a signal name indicates an “Active Low” signal.

Note 3.1 Buffer types per function on multiplexed pins are separated by a slash “/” Buffer types in parenthesis represent multiple buffer types for a single pin function.

Note 3.2 This analog input is backdrive protected.

3.2 Buffer Type Description

Note: The buffer type values are specified at VCC=3.3V

Table 3.2 Buffer Type Descriptions

BUFFER TYPE	DESCRIPTION
I _M	Digital Input
I _{AN}	Analog Input, Hardware Monitoring Block
I _M OD3	Input/Output (Open Drain), 3mA sink.
O8	Output, 8mA sink, 4mA source.
OD8	Output (Open Drain), 8mA sink.
IO8	Input/Output, 8mA sink, 4mA source.

3.3 3.3V Operation, 5V Tolerance

The EMC2300 is intended to operate with a nominal 3.3V power supply. The analog voltage pins are connected to voltage sources at their respective nominal levels. All digital signal pins are 3V switching, but are tolerant to 5V.

Chapter 4 Operational Description

4.1 Maximum Guaranteed Ratings

Operating Temperature Range	0°C to +70°C
Storage Temperature Range	-55° to +150°C
Lead Temperature Range	Refer to JEDEC Spec. J-STD-020
Maximum V_{CC}	5.0V
Positive Voltage on any pin (except for analog inputs), with respect to Ground	5.5V
Negative Voltage on any pin (except for analog inputs), with respect to Ground	-0.3V
Positive Voltage on voltage analog inputs:	
V_{ccp_in}	4.5V

Note: Stresses above those listed could cause permanent damage to the device. This is a stress rating only and functional operation of the device at any other condition above those indicated in the operation sections of this specification is not implied. When powering this device from laboratory or system power supplies, it is important that the Absolute Maximum Ratings not be exceeded or device failure can result. Some power supplies exhibit voltage spikes on their outputs when the AC power is switched on or off. In addition, voltage transients on the AC power line may appear on the DC output. If this possibility exists, it is suggested that a clamp circuit be used.

4.2 Ratings for Operation

0°C < T_A < 70°C, $V_{CC}=+3.3V\pm 10\%$						
PARAMETER	SYMBOL	MIN	TYP	MAX	UNITS	COMMENTS
Temperature-to-Digital Converter Characteristics						
Internal Temperature Accuracy		-3	± 0.25	+3	°C	0°C $\leq T_A \leq 70^\circ\text{C}$ 40°C $\leq T_A \leq 70^\circ\text{C}$
		-2		+2	°C	
External Diode Sensor Accuracy		-5	± 0.25	+5	°C	-40°C $\leq T_S \leq 125^\circ\text{C}$ 40°C $\leq T_S \leq 100^\circ\text{C}$
		-3		+3	°C	

Datasheet

0°C < TA < 70°C, VCC=+3.3V±10%						
PARAMETER	SYMBOL	MIN	TYP	MAX	UNITS	COMMENTS
Analog-to-Digital Converter Characteristics						
Total Unadjusted Error	TUE			±2	%	Note 4.1
Differential Non-Linearity	DNL		±1		LSB	
Power Supply Sensitivity	PSS		±1		%/V	
Total Monitoring Cycle Time (Cycle Mode, Default Averaging)	t _{C(Cycle)}		1.22	1.4	sec	Note 4.2
Conversion Time (Continuous Mode, Default Averaging)	t _{C(Cts)}	203	223	248	msec	Note 4.3
Input Resistance			140	200	kΩ	
ADC Resolution						10 bits Note 4.6
PWM Characteristics						
Frequency Range	f _{PWM}	11		25,000	Hz	Selected via PWM Frequency Register (Section 8.2.14)
Duty Cycle Range	DUTY	0		100	%	
TACH Characteristics						
TACH Range	TACH	332		10800	RPM	f _{PWM} = 11Hz, Edges = 3, Duty Cycle = 100%
TACH Accuracy	ΔTACH	-10		+10	%	f _{PWM} = 29.3Hz, Edges = 5, Duty Cycle = 100%
Input Buffer (VID0-VID4, TACH1-TACH4)						
Low Input Level	V _{ILI}			0.8	V	
High Input Level	V _{IHI}	2.0		V _{CC} +0.3	V	
IOD Type Buffer (SCL, SDA, PWM1, PWM2, PWM3/ADDRESS ENABLE, INT#)						
Low Input Level	V _{ILI}			0.8	V	
High Input Level	V _{IHI}	2.0		V _{CC} +0.3	V	
Hysteresis	V _{HYS}		500		mV	
Low Output Level	V _{OL}			0.4	V	I _{OL} = +4.0 mA (Note 4.5)

0°C < TA < 70°C, VCC=+3.3V±10%						
PARAMETER	SYMBOL	MIN	TYP	MAX	UNITS	COMMENTS
Leakage Current (ALL - Digital)						(Note 4.4)
Input High Current	I _{LEAKIH}			10	μA	V _{IN} = V _{CC}
Input Low Current	I _{LEAKIL}			-10	μA	V _{IN} = 0V
Digital Input Capacitance	C _{IN}			10	pF	
V_{CC} Supply Current						All outputs open, all inputs transitioning from/to 0V to/from 3.3V.
Active Mode	I _{CC}			3	mA	
Sleep Mode	I _{CC}			500	μA	
Shutdown Mode	I _{CC}			3	μA	

Notes:

- Voltages are measured from the local ground potential, unless otherwise specified.
- Typical values are at TA=25°C and represent most likely parametric norm.
- Timing specifications are tested at the TTL logic levels, V_{IL}=0.4V for a falling edge and V_{IH}=2.4V for a rising edge. TRI-STATE output voltage is forced to 1.4V.

Note 4.1 TUE (Total Unadjusted Error) includes Offset, Gain and Linearity errors of the ADC.

Note 4.2 Total Monitoring Cycle Time for cycle mode includes a one second delay plus all temperature conversions and all analog input voltage conversions.

Note 4.3 See [Table 6.2, "Conversion Cycle Timing," on page 21](#) for conversion cycle timing for all averaging options. Only the nominal default case is shown in this section.

Note 4.4 All leakage currents are measured with all pins in high impedance.

Note 4.5 The low output level for PWM pins is actually +8.0mA.

Note 4.6 The h/w monitor analog block implements a 10-bit ADC. The output of this ADC goes to an averager block, which can be configured to accumulate the averaged value of the analog inputs. The amount of averaging is programmable. The output of the averaging block produces a 12-bit temperature or voltage reading value. The 8 MSbits go to the reading register and the 4 LSbits to the A/D LSb register.

Chapter 5 SMBus Interface

The host processor communicates with the Fan Monitoring device through a series of read/write registers via the SMBus interface. SMBus is a serial communication protocol between a computer host and its peripheral devices.

5.1 Slave Address

The default Slave Address is 0101110b. If this address is desired, the designer should not ground the Address Enable# pin and should not apply a strapping resistor to the Address Select pin.

If multiple devices are implemented in a system or another SMBus device requires address 0101110b, TACH4 and PWM3 must be disabled. In this case, addressing is implemented as follows:

The board designer will apply a 10K Ω pull-down resistor to ground on the Address Enable# pin. Upon power up, the EMC2300 device will be placed into Address Enable mode and assign itself an SMBus address according to the Address Select input. The device will latch the address during the first valid SMBus transaction in which the first five bits of the targeted address match those of the EMC2300 address. This feature eliminates the possibility of a glitch on the SMBus interfering with address selection.

Table 5.1 SMBus Slave Address Options

ADDRESS ENABLE#	ADDRESS SELECT	BOARD IMPLEMENTATION	SMBUS ADDRESS [7:1]
1	X	Address Enable# pulled to VCC through resistor Note: Resistor value will be dependent on PWM circuit implemented.	0101 110b (default)
0	0	Address Enable# pulled to ground through 10k Ω resistor Address Select Pulled to ground through a 10k Ω resistor	0101 100b
0	1	Address Enable# pulled to ground through 10k Ω resistor Address Select pulled to VCC through a 10k Ω resistor	0101 101b

In this way, there can be up to three EMC2300 devices on the SMBus at any time. Multiple EMC2300 devices can be used to monitor additional processors and temperature zones.

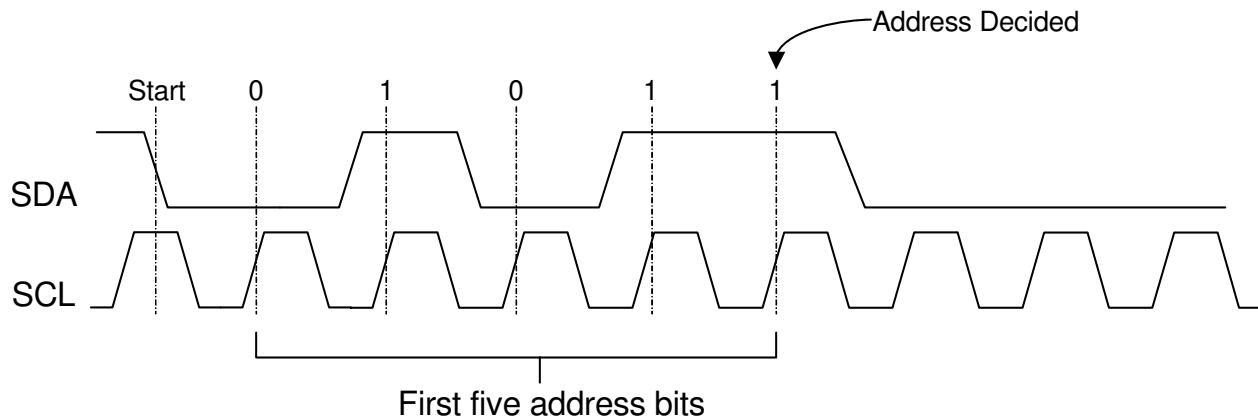
Figure 5.1 Address Selection on EMC2300

5.2 Slave Bus Interface

The EMC2300 device SMBus implementation is a subset of the SMBus interface to the host. The device is a *slave-only* SMBus device. The implementation in the device is a subset of SMBus since it only supports Write Byte and Read Byte protocols.

The Write Byte and Read Byte protocols are valid SMBus protocols for the device. This part responds to other protocols as described in the Invalid Protocol Section. Reference the System Management Bus Specification, Rev 2.0.

The SMBus interface is used to read and write the registers in the device. The register set is shown in [Chapter 8, "Register Set," on page 45](#).

5.3 Bus Protocols

Typical Write Byte and Read Byte protocols are shown below. Register accesses are performed using 7-bit slave addressing, an 8-bit register address field, and an 8-bit data field. The shading indicates the Hardware Monitor Block driving data on the SDA line; otherwise, host data is on the SDA line.

The slave address is the unique SMBus Interface Address for the Hardware Monitor Block that identifies it on SMBus. The register address field is the internal address of the register to be accessed. The register data field is the data that the host is attempting to write to the register or the contents of the register that the host is attempting to read.

Note: Data bytes are transferred MSB first.

Byte Protocols

A write byte transfer will always consist of the SMBus Interface Address byte, followed by the Internal Address Register byte, then the data byte.

The normal read protocol consists of a write to the Hardware Monitor Block with the SMBus Interface Address byte, followed by the Internal Address Register byte. Then restart the Serial Communication with a Read consisting of the SMBus Interface Address byte, followed by the data byte read from the Hardware Monitor Block. This can be accomplished by using the Read Byte protocol.

Write Byte

The Write Byte protocol is used to write data to the registers. The data will only be written if the protocol shown in [Table 5.2](#) is performed correctly. Only one byte is transferred at time for a Write Byte protocol.

Table 5.2 SMBus Write Byte Protocol

FIELD	START	SLAVE ADDR	WR	ACK	REG. ADDR	ACK	REG. DATA	ACK	STOP
Bits	1	7	1	1	8	1	8	1	1

Read Byte

The Read Byte protocol is used to read data from the registers. The data will only be read if the protocol shown in [Table 5.3](#) is performed correctly. Only one byte is transferred at time for a Read Byte protocol.

Table 5.3 SMBus Read Byte Protocol

FIELD:	START	SLAVE ADDR	WR	ACK	REG. ADDR	ACK	START	SLAVE ADDR	RD	ACK	REG. DATA	NACK	STOP
Bits:	1	7	1	1	8	1	1	7	1	1	8	1	1

5.4 Invalid Protocol Response Behavior

Registers that are accessed with an invalid protocol will not be updated. A register will only be updated following a valid protocol. The only valid protocols are the Write Byte and Read Byte protocols, which are described above.

The EMC2300 device responds to three SMBus slave addresses:

1. The SMBus slave address that supports the valid protocols defined in the previous sections is determined by the level on the Address Select and Address Enable pins as shown in [Section 5.1](#), "Slave Address," on page 15.
2. SMBus Alert Response (0001 100). The SMBus will only respond to the SMBus Alert Response Address if the SMBus Alert Response interrupt was generated to request a response from the Host. The SMBus Alert Response is defined in [Section 5.10](#), "SMBus Alert Response Address," on page 18.

Attempting to communicate with the Hardware Monitor Block over SMBus with an invalid slave address, or invalid protocol will result in no response, and the SMBus Slave Interface will return to the idle state.

The only valid registers that are accessible by the SMBus slave address are the registers defined in the Registers Section. See [Section 5.4.1](#), "Undefined Registers" for response to undefined registers.

5.4.1 Undefined Registers

Reads to undefined registers return 00h. Writes to undefined registers have no effect and return no error.

5.5 General Call Address Response

The EMC2300 will not respond to a general call address of 0000_000.

5.6 Slave Device Time-Out

The EMC2300 supports the slave device timeout as per the SMBus Specification, v2.0.

According to SMBus specification, v2.0 devices in a transfer can abort the transfer in progress and release the bus when any single clock low interval exceeds 25ms ($T_{\text{TIMEOUT, MIN}}$). Devices that have detected this condition must reset their communication and be able to receive a new START condition no later than 35ms ($T_{\text{TIMEOUT, MAX}}$).

Note: Some simple devices do not contain a clock low drive circuit; this simple kind of device typically may reset its communications port after a start or stop condition

5.7 Stretching the SCLK Signal

The EMC2300 supports stretching of the SCLK by other devices on the SMBus but will not stretch the SCLK itself.

5.8 SMBus Timing

The SMBus Slave Interface complies with the SMBus AC Timing Specification. See the SMBus timing diagram shown in the section titled [Section 9.2, "SMBus Interface," on page 76](#).

5.9 Bus Reset Sequence

The SMBus Slave Interface will reset and return to the idle state upon a START field followed immediately by a STOP field.

5.10 SMBus Alert Response Address

The EMC2300 device responds to the SMBus Alert Response Address, 0001 100, if the INTEN bit (register 7Ch bit 2) is set and one or more status events bits are high. The interrupt signal (INT#), which can be enabled on either the PWM2 or TACH3 pins, can be used as the SMBALERT#. See the section describing the [Interrupt Status Registers on page 23](#) and the section describing the [Interrupt Pin on page 25](#) for more details on interrupts.

The device can signal the host that it wants to talk by pulling the SMBALERT# low, if a status bit is set in one of the interrupt status registers and properly enabled onto the INT# pin. The host processes the interrupt and simultaneously accesses all SMBALERT# devices through a modified Receive Byte operation with the Alert Response Address (ARA).

The EMC2300 device, which pulled SMBALERT# low, will acknowledge the Alert Response Address and respond with its device address. The 7-bit device address provided by the EMC2300 device is placed in the 7 most significant bits of the byte. The eighth bit can be a zero or one.

Table 5.4 Modified SMBus Receive Byte Protocol Response to ARA

	START	ALERT RESPONSE ADDRESS	RD	ACK	EMC2300 SLAVE ADDRESS	NACK	STOP
FIELD:							
Bits:	1	7	1	1	8	1	1

After acknowledging the slave address, the EMC2300 device will disengage the SMBALERT# pull-down by clearing the INT enable bit. If the condition that caused the interrupt remains, the Fan Control device will reassert the SMBALERT# on the next monitoring cycle, provided the INT enable bit has been set back to '1' by software.



Datasheet

Note: The INT# signal is an alternate function on the PWM2 and TACH3 pins. The EMC2300 device will respond to the SMBus Alert Response address even if the INT# signal is not selected as the alternate function on one of these pins as long as the following conditions exist: the INTEN bit (register 7Ch bit 2) is set, an individual status bit is set in one of the interrupt status registers, and the corresponding group enable bit is set. Each interrupt event must be enabled into the interrupt status registers, and the status bits must be enabled onto the INT# signal via the group enable bits for each type of event (i.e., temperature, voltage and fan). See the section titled [Interrupt Status Registers on page 23](#).

Chapter 6 Hardware Monitoring

The following sub-sections describe the EMC2300 Hardware Monitoring features.

6.1 Input Monitoring

The EMC2300 device's monitoring function is started by writing a '1' to the START bit in the **Ready/Lock/Start** Register (0x40). Measured values from the analog inputs and temperature sensors are stored in Reading Registers. The values in the reading registers can be accessed via the SMBus interface. These values are compared to the programmed limits in the Limit Register. The out-of-limit and diode fault conditions are stored in the Interrupt Status Registers.

6.2 Resetting the EMC2300

6.2.1 Power-On Reset

All the registers in the Hardware Monitor Block, except the reading registers, reset to a default value when power is applied to the block. The default state of the register is shown in the table in the Register Summary subsection. The default state of Reading Registers are not shown because these registers have indeterminate power on values.

Note: Usually the first action after power up is to write limits into the Limit Registers.

6.2.2 Soft Reset (Initialization)

Setting bit 7 of the CONF register performs a soft reset. This bit is self-clearing. Soft Reset performs reset on all the registers except the Reading Registers.

6.3 Monitoring Modes

The Hardware Monitor Block supports two Monitoring modes: Continuous Mode and Cycle Mode. These modes are selected using bit 1 of the Special Function Register (7Ch). The following subsections contain a description of these monitoring modes.

The hardware monitor conversion clock is 45KHz \pm 10%. Temperature conversions take 96 clocks, each (2.133ms nom.); voltage conversions take 68 clocks, each (1.511ms nom). The time to complete a conversion cycle depends upon the number of inputs in the conversion sequence to be measured (see [Table 6.3, "ADC Conversion Sequence," on page 22](#)) and the amount of averaging per input, which is selected using the AVG[2:0] bits in the Special Function register (see [Register 7Ch: Special Function Register on page 67](#)).

For each mode, there are four options for the number of measurements that are averaged for each temperature and voltage reading. These options are selected using bits[7:5] of the Special Function register (7Ch). These bits are defined as follows:

Bits [7:5] AVG[2:0]

The AVG[2:0] bits determine the amount of averaging for each of the measurements that are performed by the hardware monitor before the reading registers are updated ([Table 6.1](#)). The AVG[2:0] bits are priority encoded where the most significant bit has highest priority. For example, when the AVG2 bit is asserted, 32 averages will be performed for each measurement before the reading registers are updated regardless of the state of the AVG[1:0] bits.

Table 6.1 AVG[2:0] Bit Decoder

SFTR[7:5]			MEASUREMENTS PER READING			
AVG2	AVG1	AVG0	REMOTE DIODE 1	REMOTE DIODE 2	INTERNAL DIODE	ALL VOLTAGE READINGS (VCCP, AND VCC)
0	0	0	128	128	8	8
0	0	1	16	16	1	1
0	1	X	16	16	16	16
1	X	X	32	32	32	32

Note: The default for the AVG[2:0] bits is '010'b.

To calculate conversion cycle timing for a given averaging mode:

- Compute total number of temperature conversions (TEMP_CONV)
- Compute total number of voltage conversions (VOLT_CONV)
- Calculate Time to complete all conversions is:

$$\text{Total Conversion Time} = (\text{TEMP_CONV}) * 96 / (45\text{kHz} \pm 10\%) + (\text{VOLT_CONV}) * 68 / (45\text{kHz} \pm 10\%)$$

Example: To calculate the nominal conversion time FOR AVG[2:0] = 001b.

$$\text{Total Conversion Time} = (\text{TEMP_CONV}) * 96 / (45\text{kHz}) + (\text{VOLT_CONV}) * 68 / (45\text{kHz})$$

$$\text{Total Conversion Time} = (16 + 16 + 1) * 96 / (45\text{kHz}) + (2 * 1) * 68 / (45\text{kHz})$$

$$\text{Total Conversion Time} = (33) * 2.133\text{ms} + (2) * 1.511\text{ms} = \sim 73\text{ms}$$

Table 6.2 illustrates the min., nom., and max. conversion cycle timing for each of the four averaging modes.

Table 6.2 Conversion Cycle Timing

AVG[2:0]	TOTAL TEMPERATURE CONVERSIONS	TOTAL VOLTAGE CONVERSIONS	CONVERSION CYCLE TIME (MSEC)		
			MIN.	NOM.	MAX.
000	$(2 \times 128) + (1 \times 8) = 264$	$2 \times 8 = 16$	536	587	652
001	$(2 \times 16) + (1 \times 1) = 33$	$2 \times 1 = 2$	67	73	82
01X (default)	$3 \times 16 = 48$	$2 \times 16 = 32$	191	210	233
1XX	$3 \times 32 = 96$	$2 \times 32 = 64$	382	420	466

Note 6.1 The hardware monitor conversion clock is $45\text{KHz} \pm 10\%$.

Note 6.2 Temperature conversions take 96 clocks, each (2.133ms nom.); Voltage conversions take 68 clocks, each (1.511ms nom).

6.3.1 Continuous Monitoring Mode

In the continuous monitoring mode, the sampling and conversion process is performed continuously for each voltage and temperature reading after the Start bit is set high. The time for each voltage and temperature reading is shown above for each measurement option.

The continuous monitoring function is started by doing a write to the Ready/Lock/Start Register, setting the Start bit (Bit 0) high. The part then performs a “round robin” sampling of the inputs, in the order shown below (see [Table 6.3](#)). Sampling of all values occurs in a nominal 210ms (default - see [Table 6.2, “Conversion Cycle Timing,” on page 21](#)).

Table 6.3 ADC Conversion Sequence

SAMPLING ORDER	REGISTER
1	Remote Diode Temp Reading 1
2	Ambient Temperature reading
3	VCC reading
4	Vccp (processor) reading
5	Remote Diode Temp Reading 2

When the continuous monitoring function is started, it cycles through each measurement in sequence, and it continuously loops through the sequence approximately once every 210ms (default - see [Table 6.2, “Conversion Cycle Timing,” on page 21](#)). Each measured value is compared to values stored in the Limit registers. When the measured value violates the programmed limit the Hardware Monitor Block will set a corresponding status bit in the Interrupt Status Registers.

If auto fan option is selected, the hardware will adjust the operation of the fans accordingly. See [Auto Fan Control Operating Mode on page 31](#).

The results of the sampling and conversions can be found in the Reading Registers and are available at any time.

6.3.2 Cycle Monitoring Mode

In cycle monitoring mode, the part completes all sampling and conversions, then waits approximately one second to repeat the process. It repeats the sampling and conversion process typically every 1.2 seconds (1.4 sec max - default averaging enabled). The sampling and conversion of each voltage and temperature reading is performed once every monitoring cycle. This is a power saving mode.

The cycle monitoring function is started by doing a write to the Ready/Lock/Start Register, setting the Start bit (Bit 0) high. The part then performs a “round robin” sampling of the inputs, in the order shown above.

When the cycle monitoring function is started, it cycles through each measurement in sequence, and it produces a converted voltage and temperature reading for each input. The state machine waits approximately one second before repeating this process. Each measured value is compared to values stored in the Limit registers. When the measured value violates (or is equal to) the programmed limit the Hardware Monitor Block will set a corresponding status bit in the Interrupt Status Registers.

If auto fan option is selected, the hardware will adjust the operation of the fans accordingly. See the section titled [Auto Fan Control Operating Mode on page 31](#).

The results of each sampling and conversion can be found in the Reading Registers and are available at any time, however, they are only updated once per conversion cycle.

6.4 Interrupt Status Registers

The Hardware Monitor Block contains two interrupt status registers: [Register 41h: Interrupt Status Register 1 on page 55](#) and [Register 42h: Interrupt Status Register 2 on page 56](#). These registers are used to reflect the state of all temperature, voltage and fan violation of limit error conditions and diode fault conditions that the Hardware Monitor Block monitors.

When an error occurs during the conversion cycle, its corresponding bit is set in its respective interrupt status register. The bit remains set until the register is read by software, at which time the bit will be cleared to '0' if the associated error event no longer violates the limit conditions or if the diode fault condition no longer exists. Reading the register will not cause a bit to be cleared if the source of the status bit remains active.

These registers are read only – a write to these registers have no effect. These registers default to 0x00 on VCC POR and Initialization.

See the description of the Interrupt Status registers in [Chapter 8, "Register Set," on page 45](#).

Each interrupt status bit has a corresponding bit located in an interrupt enable register, which may be used to enable/disable the individual event from setting the status bit. See the following figure for the status and enable bits used to control the interrupt bits and INT# pin.

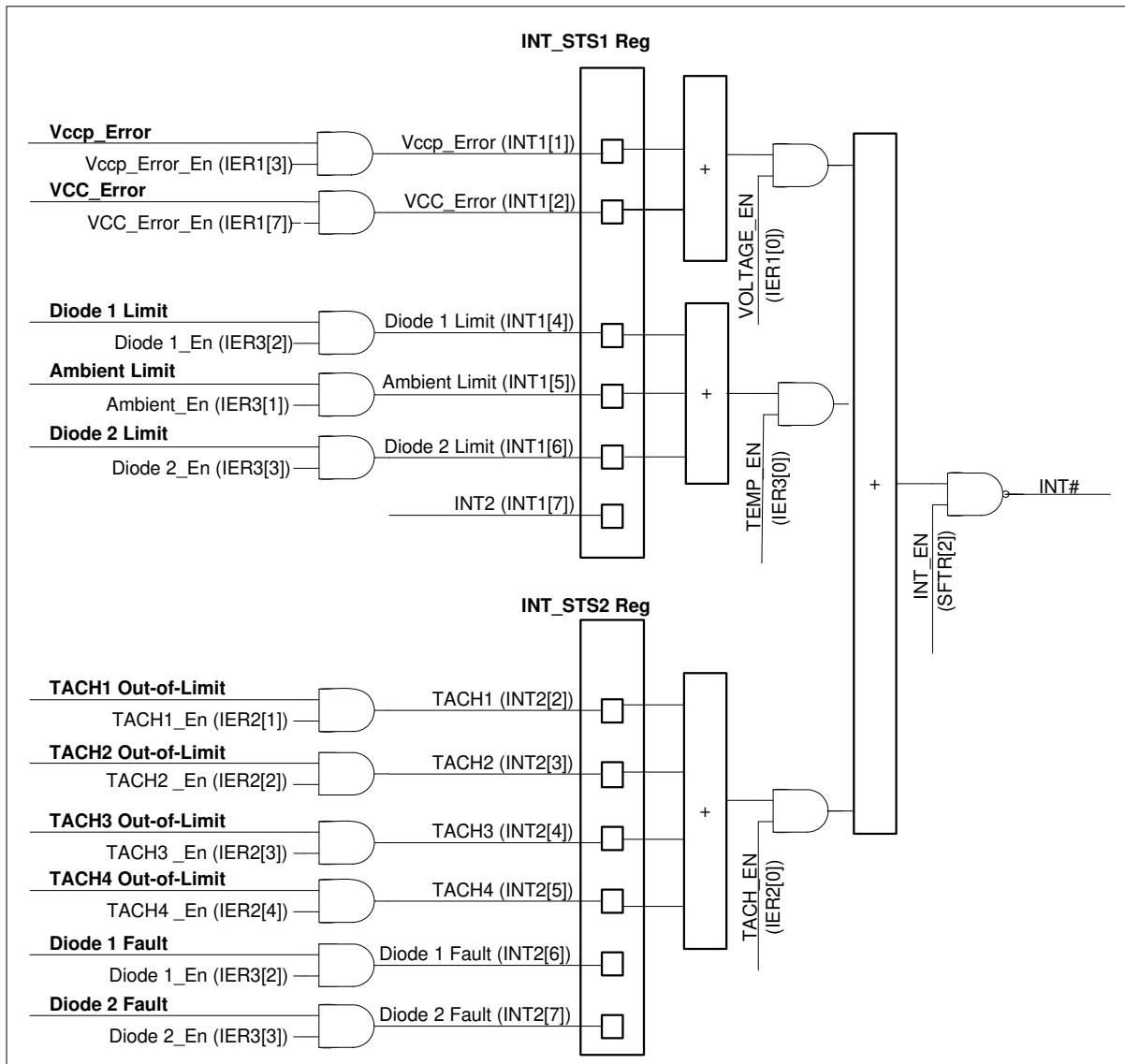
Figure 6.1 Interrupt Control

Note: The diode fault bits are not mapped directly to the INT# pin. A diode fault condition forces the diode reading register to a value of 80h, which will generate a Diode Error condition. See section [Diode Fault on page 24](#).

6.4.1 Diode Fault

The EMC2300 Chip automatically sets the associated diode fault bit to 1 when any of the following conditions occur on the Remote Diode pins:

- The positive and negative terminal are an open circuit.
- Positive terminal is connected to VCC
- Positive terminal is connected to ground
- Negative terminal is connected to VCC
- Negative terminal is connected to ground

Datasheet

The occurrence of a fault will cause 80h to be loaded into the associated reading register, except for the case when the negative terminal is connected to ground. A temperature reading of 80h will cause the corresponding diode error bit to be set. This will cause the INT# pin to become active if the individual, group (TEMP), and global enable (INTEN) bits are set.

Notes:

- The individual remote diode enable bits and the TEMP bit are located in [Table 8.50 on page 71](#). The INTEN bit is located in bit[2] of [Register 7Ch: Special Function Register on page 67](#).
- When 80h is loaded into the Remote Diode Reading Register the PWM output(s) controlled by the zone associated with that diode input will be forced to full on. See [Thermal Zones on page 28](#).

If the diode is disabled, the fault bit in the interrupt status register will not be set. In this case, the occurrence of a fault will cause 00h to be loaded into the associated reading register. The limits must be programmed accordingly to prevent unwanted fan speed changes based on this temperature reading. If the diode is disabled and a fault condition does not exist on the diode pins, then the associated reading register will contain a “valid” reading.

6.5 Interrupt Pin

The INT# function is used as an interrupt output for out-of-limit temperature, voltage events, and/or fan errors.

- The INT# signal can be enabled onto the PWM2 or the TACH3 pins.
To configure the PWM2/INT# pin for the interrupt function, set bit[1] P2INT of the CONF register (7Fh) to ‘1’
To configure the TACH3/INT# pin for the interrupt function, set bit[0] T3INT of the CONF register (7Fh) to ‘1’
- To enable the interrupt pin to go active, set bit 2 of the Special Function Register (7Ch) to ‘1’.

To enable temperature event, voltage events and/or fan events onto the INT# pin:

- To enable out-of-limit temperature events set bit[0] of the Interrupt Enable 3 (TEMP) register (82h) to ‘1’.
- To enable out-of-limit voltage events set bit[0] of the Interrupt Enable 1 (VOLT) register (7Eh) to ‘1’
- To enable Fan tachometer error events set bit[0] of the Interrupt Enable 2 (Fan Tachs) register (80h) to ‘1’.

See [Figure 6.1 on page 24](#). The following description assumes that the interrupt enable bits for all events are set to enable the interrupt status bits to be set.

If the internal or remote temperature reading violates the low or high temperature limits, INT# will be forced active low (if all the corresponding enable bits are set: individual enable bits (D1_EN, D2_EN, and/or AMB_EN), group enable bit (TEMP_EN) and the global enable bit (INTEN)). This pin will remain low while the Internal Temp Error bit or one or both of the Remote Temp Error bits in Interrupt Status 1 Register is set and the enable bit is set.

The INT# pin will not become active low as a result of the remote diode fault bits becoming set. However, the occurrence of a fault will cause 80h to be loaded into the associated reading register, which will cause the corresponding diode error bit to be set. This will cause the INT# pin to become active if enabled.

The INT# pin can be enabled to indicate out-of-limit voltages. Bit[0] of the Interrupt Enable 1 (VOLT) register (7Eh) is used to enable this option. When this bit is set, if one or more of the voltage readings violates the low or high limits, INT# will be forced active low (if all the corresponding enable bits are set: individual enable bits (VCC_Error_En, VCCP_Error_En), group enable (VOLT_EN), and global enable (INT_EN)). This pin will remain low while the associated voltage error bit in the Interrupt Status Register 1 or Interrupt Status Register 2 is set.