



Chipsmall Limited consists of a professional team with an average of over 10 year of expertise in the distribution of electronic components. Based in Hongkong, we have already established firm and mutual-benefit business relationships with customers from,Europe,America and south Asia,supplying obsolete and hard-to-find components to meet their specific needs.

With the principle of "Quality Parts,Customers Priority,Honest Operation,and Considerate Service",our business mainly focus on the distribution of electronic components. Line cards we deal with include Microchip,ALPS,ROHM,Xilinx,Pulse,ON,Everlight and Freescale. Main products comprise IC,Modules,Potentiometer,IC Socket,Relay,Connector.Our parts cover such applications as commercial,industrial, and automotives areas.

We are looking forward to setting up business relationship with you and hope to provide you with the best service and solution. Let us make a better world for our industry!



Contact us

Tel: +86-755-8981 8866 Fax: +86-755-8427 6832

Email & Skype: info@chipsmall.com Web: www.chipsmall.com

Address: A1208, Overseas Decoration Building, #122 Zhenhua RD., Futian, Shenzhen, China



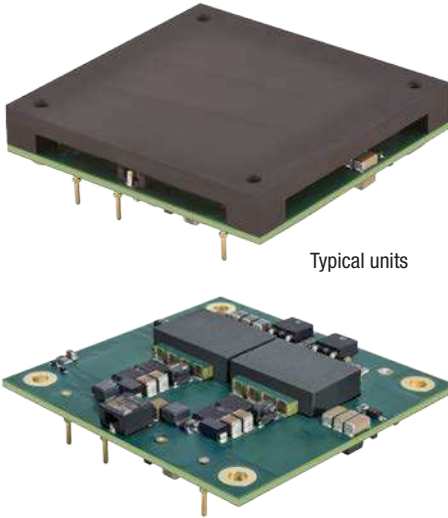

Typical units

FEATURES

- Industry-Standard "Half-Brick" footprint
- 162W output power @ 24-72Vin
- Up to 91.5% Efficiency at 54V output (typical)
- On/Off Control (Negative logic)
- Monotonic startup into pre-bias output conditions
- Over-current, Output & Over-temperature protection
- Low output ripple and noise
- Strong thermal derating characteristics
- Operational Temperature Range -40°C to +85°C with baseplate
- 2250V I/O isolation
- Output short-circuit protection (hiccup technique)

PRODUCT OVERVIEW

The EMH-54/3-Q48N-C module offers 54V output at 3 amps in a Half Brick footprint DC/DC power converter. These compact modules measure 2.4" x 2.3" x 0.5" (61 x 58.4 x 12.7 mm) with baseplate and offer the industry-standard Half-Brick footprint. The product is designed to fully comply with RoHS-6 directive.

The modules offer wide range input voltage of 18-72V. The EMH topology offers high efficiency up to 91.5%, good regulation, low ripple/noise, and a fast dynamic load response. The module supplies up to 162 Watts of power and isolation rated at 2250V for basic insulation. EMH models are

designed for demanding telecom, POE (power over Ethernet), datacom, and networking applications. EMHs feature input filters, input under voltage, output current limiting, short-circuit protection, and thermal shutdown.

ORDERING GUIDE SUMMARY

| Model | Vout Range | Iout Range | Vin Range | Ripple/Noise | Efficiency |
|--------------|------------|------------|-----------|--------------|------------|
| EMH-54/3-Q48 | 54V | 0.2-3A | 18-72V | 250mVp-p | 91.5% |

INPUT CHARACTERISTICS

| Parameter | Typ. @ 25°C, full load | Notes |
|-----------------------------------|------------------------|-------------|
| Voltage Range | 18-72 Volts | 48V nominal |
| Input Current, full power | 3.67 Amps | VIN = 48V |
| Turn On/start-up threshold | 17.5 Volts | |
| Undervoltage Shutdown | 17 Volts | |
| No load Input Current | 40mA | VIN = 48V |

OUTPUT CHARACTERISTICS

| Parameter | Typ. @ 25°C, full load | Notes |
|-----------------------------------|------------------------|--------------------------|
| Voltage | 54 Volts | ±2% |
| Current | 0.2 to 3 Amps | 0.2A min load required |
| Power Output | 162 Watts | |
| Ripple & Noise | 250mVp-p | 20MHz bandwidth |
| Line and Load Regulation | ±0.125%/±0.2% | |
| Overcurrent Protection | 4 Amps | With hiccup auto-restart |
| Overtemperature Protection | +135°C | |
| Efficiency (minimum) | 89.5% | |
| Efficiency (typical) | 91.5% | |

GENERAL SPECIFICATIONS

| Parameter | Typ. @ 25°C, full load | Notes |
|---|--|--------------------------------------|
| Dynamic Load Response | 300µsec | 50-75-50% step to ±1 of final value |
| Operating Temperature Range | -40 to +85°C | With baseplate, see derating curve |
| Absolute Operating Temperature Range | -40 to +105°C | Measured at Thermistor, see derating |
| Safety Features | UL 60950-1, 2nd edition | |
| | CSA-C22.2 No.60950-1 and IEC/EN60950-1 | |

PHYSICAL SPECIFICATIONS

| Parameter | Inches | Millimeters |
|----------------------------------|------------------|--------------------|
| Open frame (no baseplate) | 2.4 x 2.3 x 0.43 | 61 x 58.4 x 10.92 |
| With baseplate | 2.4 X 2.3 X 0.5 | 61.0 x 58.4 x 12.7 |



PERFORMANCE SPECIFICATIONS SUMMARY AND ORDERING GUIDE

| Root Model ① | Output | | | | | | Input | | | | Efficiency | | Dimensions with baseplate (Inches) | |
|--------------|--------------------------|-------------------------------|---------------|----------------|------|-------------------|-------|------------------------------|---------------|--------------------------------|------------------------------------|-------|------------------------------------|-------------|
| | V _{OUT} (Volts) | I _{OUT} (Amps, Max.) | Power (Watts) | R/N (mV pk-pk) | | Regulation (Max.) | | V _{IN} Nom. (Volts) | Range (Volts) | I _{IN} , no load (mA) | I _{IN} , full load (Amps) | Min. | | Typ. |
| | | | | Typ. | Max. | Line | Load | | | | | | | |
| EMH-54/3-Q48 | 54 | 3 | 162 | 250 | 350 | ±0.125% | ±0.2% | 48 | 18-72 | 40 | 3.67 | 89.5% | 91.5% | 2.4x2.3x0.5 |

- ① Please refer to the full part number structure for additional ordering part numbers and options.
- ② All specifications are typical at nominal line voltage and full load, +25°C, unless otherwise noted. Units are tested with a 1uF ceramic external output capacitor and a 100uF and 2.2uF external input capacitor.
- ③ Full power continuous output requires baseplate installation. Please refer to the derating curves.

PART NUMBER STRUCTURE

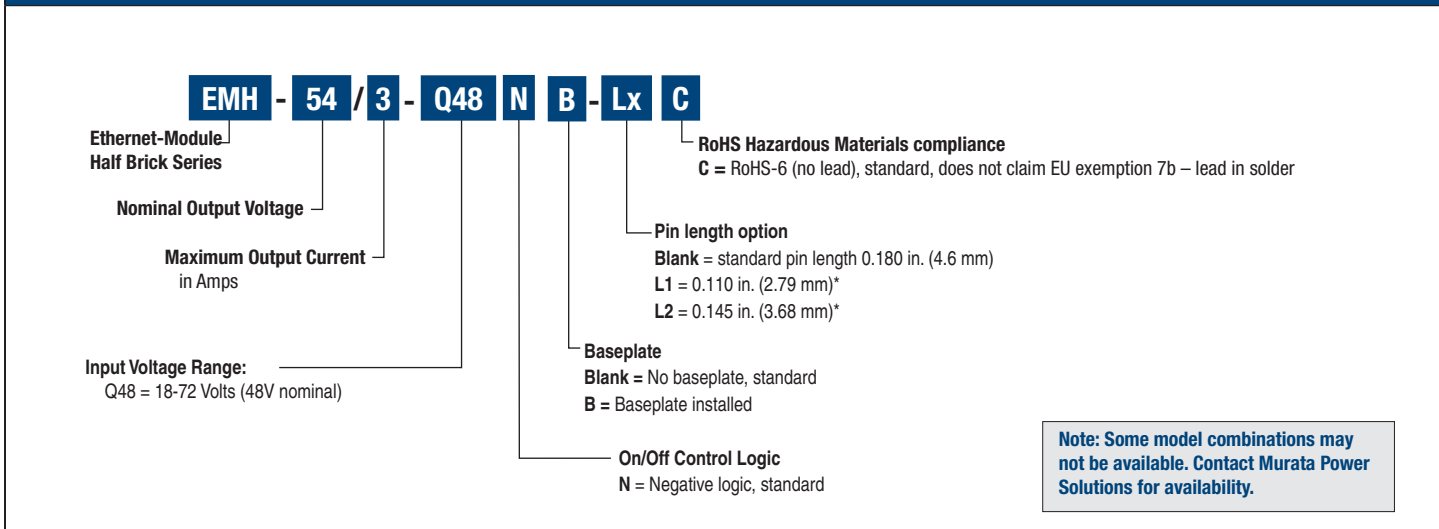

Customer Configured Part Numbers:

- EMH-31310-C (special version of the EMH-54/3-Q48NB-C)
 - Includes conformal coating
 - Isolation tested to 2,828Vdc Input-to-Output per IEEE 1613
 - Pin length of 0.180 inches ±0.02 (4.6mm ±0.508)

FUNCTIONAL SPECIFICATIONS

| ABSOLUTE MAXIMUM RATINGS | Conditions ① | Minimum | Typical/Nominal | Maximum | Units |
|--|--|---------|-----------------|---------|-------------------------|
| Input Voltage, Continuous | Full power operation | 0 | | 72 | Vdc |
| Isolation Voltage | Input to output tested | | | 2250 | Vdc |
| Input Reverse Polarity | None, install external fuse | | None | | Vdc |
| On/Off Remote Control | Power on or off, referred to -Vin | 0 | | 15 | Vdc |
| Output Power | | 0 | | 164.32 | W |
| Output Current | Current-limited, no damage, short-circuit protected | 0.2 | | 3 | A |
| Storage Temperature Range | Vin = Zero (no power) | -55 | | 125 | °C |
| Absolute maximums are stress ratings. Exposure of devices to greater than any of these conditions may adversely affect long-term reliability. Proper operation under conditions other than those listed in the Performance/Functional Specifications Table is not implied nor recommended. | | | | | |
| INPUT | | | | | |
| Operating voltage range ② | | 18 | 48 | 72 | Vdc |
| Turn On/Start-up threshold | Rising input voltage | 16.5 | 17.5 | 18 | Vdc |
| Ambient temperature > 60°C | | | | 19 | Vdc |
| Turn Off/Undervoltage lockout | Tested at 2.6A | 15 | 17 | 17.5 | Vdc |
| Turn-On/Turn-Off Hysteresis | | 1.0 | 1.05 | 1.2 | Vdc |
| Reverse Polarity Protection | None, install external fuse | | None | | Vdc |
| Recommended External Fuse | Fast blow | | 20 | | A |
| Internal Filter Type | | | L-C | | |
| Input current | | | | | |
| Full Load Conditions | Vin = nominal | | 3.67 | 3.83 | A |
| Low line input current | Vin @ Min. @2.6A | | 8.52 | 8.84 | A |
| Inrush Transient | | | 0.1 | | A ² -Sec. |
| Short Circuit Input Current | | | 250 | 350 | mA |
| No Load Input Current | Iout = minimum, unit=ON | | 40 | 80 | mA |
| Shutdown Mode Input Current (Off, UV, OT) | | | 5 | 10 | mA |
| Reflected (back) ripple current ③ | Measured at input with specified filter | | 40 | 80 | mA, p-p |
| GENERAL and SAFETY | | | | | |
| Efficiency | Vin = 48V, full load | 89.5 | 91.5 | | % |
| | Vin = 24V, full load | 89.5 | 91.5 | | % |
| | Vin = 18V, full load | 89.5 | 91 | | % |
| Isolation | | | | | |
| Isolation Voltage: no baseplate | Input to output, continuous | 2250 | | | Vdc |
| | Input to output, continuous | 2250 | | | Vdc |
| Isolation Voltage: with baseplate | Input to Baseplate, continuous | 1500 | | | |
| | Output to Baseplate, continuous | 750 | | | |
| Insulation Safety Rating | | | basic | | |
| Isolation Resistance | | | 100 | | Mohm |
| Isolation Capacitance | | | 5,000 | | pF |
| Safety (Designed to meet the following requirements) | UL-60950-1, CSA-C22.2 No.60950-1, IEC/EN60950-1, 2nd Edition | | Yes | | |
| Calculated MTBF | Per Telcordia SR332, issue 1 class 3, ground fixed, Tambient=+25°C | | 1.8+ | | Hours x 10 ⁶ |
| DYNAMIC CHARACTERISTICS | | | | | |
| Fixed Switching Frequency | | 387 | 430 | 473 | KHz |
| Startup Time | Power On to Vout regulated 10-90% (50% resistive load) | | 40 | 60 | mS |
| Startup Time | Remote ON to 10% Vout (50% resistive load) | | 30 | 50 | mS |
| Dynamic Load Response | 50-75-50% load step, settling time to within ±2% of Vout | | 300 | 450 | µSec |
| Dynamic Load Peak Deviation | same as above | | ±1000 | ±1250 | mV |
| FEATURES and OPTIONS | | | | | |
| Remote On/Off Control ④ | | | | | |
| "N" suffix: | | | | | |
| Negative Logic, ON state | ON = Pin grounded or external voltage | -0.7 | | 0.8 | V |
| Negative Logic, OFF state | OFF = Pin open or external voltage | 5 | | 15 | V |
| Control Current | open collector/drain | | 1 | 2 | mA |
| Base Plate | "B" suffix | | | | |

FUNCTIONAL SPECIFICATIONS (CONT.)

| OUTPUT | | | | | |
|---|---|--------|---------------------|--------|---------------|
| Total Output Power | See Derating | 0.0 | 161.1 | 164.32 | W |
| Voltage | | | | | |
| Nominal Output Voltage | No trim | 52.626 | 53.7 | 54.774 | Vdc |
| Setting Accuracy | At 50% load | -2 | | 2 | % of Vnom. |
| Output Voltage Range | User-adjustable ⑥ | | N/A | | % of Vnom. |
| Overvoltage Protection | Via magnetic feedback | | 65 | 67 | Vdc |
| Current | | | | | |
| Output Current Range: 24-72 Vin | | 0.2 | 3 | 3 | A |
| Output Current Range: 18-24 Vin | | 0.2 | 2.6 | 2.6 | A |
| Minimum Load | | | 0.2 | | |
| Current Limit Inception ⑤ | 98% of Vnom., after warmup | 3.2 | 3.9 | 4.7 | A |
| Short Circuit | | | | | |
| Short Circuit Current | Hiccup technique, autorecovery within ±1% of Vout, non-latching | | 0.5 | 1 | A |
| Short Circuit Duration (remove short for recovery) | Output shorted to ground, no damage | | Continuous | | |
| Short circuit protection method | Current limiting | | | | |
| Regulation ⑥ | | | | | |
| Line Regulation | Vin=min. to max. Vout=nom., 50% load | | | ±0.125 | % |
| Load Regulation | Iout=min. to max. Vin=48V. | | | ±0.2 | % |
| Ripple and Noise | 5 Hz- 20 MHz BW | | 250 | 350 | mV pk-pk |
| Temperature Coefficient | At all outputs | | 0.02 | | % of Vnom./°C |
| Maximum Capacitive Loading | Low ESR, resistive load | 0 | | 3300 | µF |
| MECHANICAL (Through Hole Models) | | | | | |
| Outline Dimensions (open frame) | | | 2.4 x 2.3 x 0.43 | | Inches |
| | | | 61.0 x 58.4 x 10.92 | | mm |
| Outline Dimensions (with baseplate) | | | 2.4 X 2.3 X 0.5 | | Inches |
| | LxWxH (Please refer to outline drawing) | | 61.0 x 58.4 x 12.7 | | mm |
| Weight (with baseplate) | | | 2.3 | | Ounces |
| | | | 67.13 | | Grams |
| Through Hole Pin Diameter | See mechanical drawing | | 0.04 & 0.080 | | Inches |
| | | | 1.016 & 2.032 | | mm |
| Through Hole Pin Material | | | Copper alloy | | |
| TH Pin Plating Metal and Thickness | Nickel subplate | | 50 | | µ-inches |
| | Gold overplate | | 5 | | µ-inches |
| Case or Baseplate Material | | | Aluminum | | |
| ENVIRONMENTAL | | | | | |
| Operating Ambient Temperature Range | With derating | -40 | | 85 | °C |
| Operating Ambient Temperature Range with Baseplate | Maximum baseplate temperature: Converter delivers full rated power at max baseplate temp. | -40 | | 100 | °C |
| Absolute Operating Temperature Range | Measured @ Thermistor or in the middle of baseplate | -40 | | 105 | °C |
| Storage Temperature | Vin = Zero (no power) | -40 | | 125 | °C |
| Thermal Protection/Shutdown | | 125 | 135 | 140 | °C |
| Electromagnetic Interference Conducted, EN55022/CISPR22 | External filter required | | B | | Class |
| Radiated, EN55022/CISPR22 | | | B | | Class |
| RoHS rating | | | RoHS-6 | | |

Notes

- ① Unless otherwise noted, all specifications are at nominal input voltage, nominal output voltage and full load. General conditions are +25° Celsius ambient temperature, near sea level altitude, natural convection airflow. All models are tested and specified with an external 1 µF multi-layer ceramic output capacitor. The external input capacitors are 100µF and 2.2µF ceramic. All capacitors are low-ESR types wired close to the converter. These capacitors are necessary for our test equipment and may not be needed in the user's application.
- ② The module will operate when input voltage is within the 18-72V Operating Voltage Range. Output regulation at full load will be achieved only when Vin ≥ 18V.
- ③ Input (back) ripple current is tested and specified over 5 Hz to 20 MHz bandwidth. Input filtering is Cbus = 220 µF, Cin = 33 µF and Lbus = 12 µF.
- ④ The Remote On/Off Control is referred to -Vin.
- ⑤ Over-current protection is non-latching with auto recovery (Hiccup)
- ⑥ Regulation specifications describe the output voltage changes as the line voltage or load current is varied from its nominal or midpoint value to either extreme.

TYPICAL PERFORMANCE DATA

Maximum Current Temperature Derating vs. Airflow
(Vin = 18, airflow from Pin 1 to Pin 4 on PCB, no Baseplate)

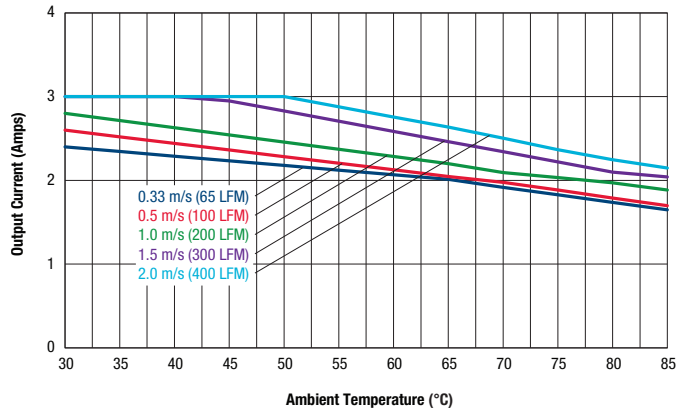

Maximum Current Temperature Derating vs. Airflow
(Vin = 24V, airflow from from Pin 1 to Pin 4 on PCB, no Baseplate)

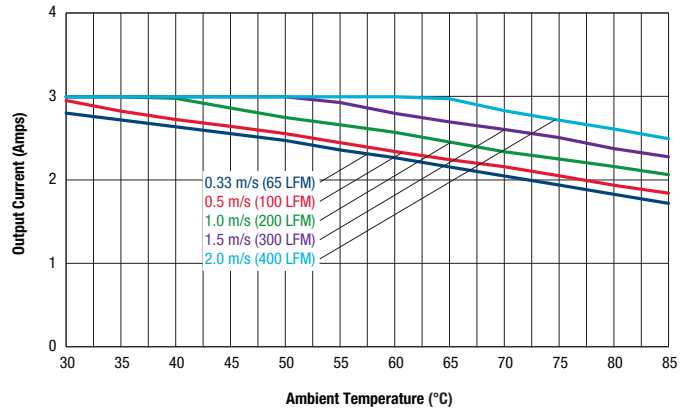

Maximum Current Temperature Derating vs. Airflow
(Vin = 36, airflow from Pin 1 to Pin 4 on PCB, no Baseplate)

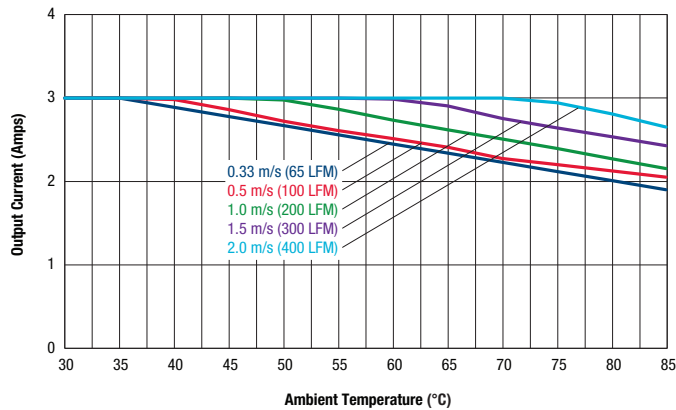

Maximum Current Temperature Derating vs. Airflow
(Vin = 48V, airflow from from Pin 1 to Pin 4 on PCB, no Baseplate)

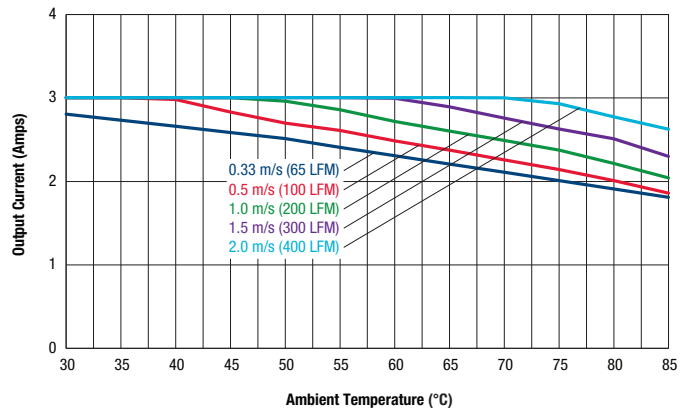

Maximum Current Temperature Derating vs. Airflow
(Vin = 60, airflow from Pin 1 to Pin 4 on PCB, no Baseplate)

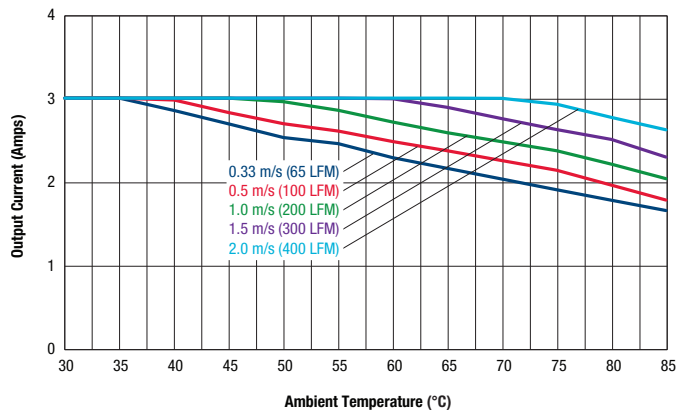

Maximum Current Temperature Derating vs. Airflow
(Vin = 72V, airflow from from Pin 1 to Pin 4 on PCB, no Baseplate)

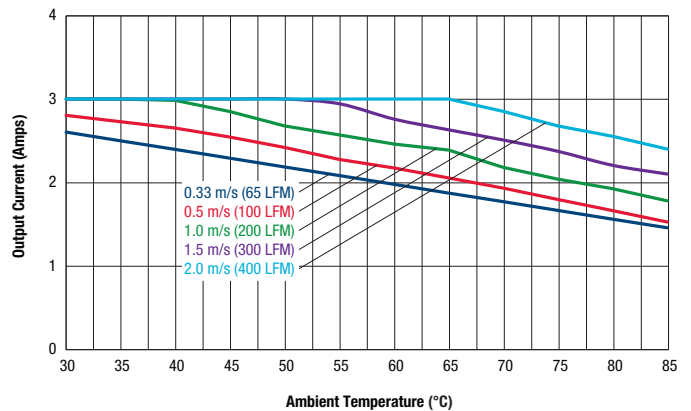

TYPICAL PERFORMANCE DATA

Maximum Current Temperature Derating vs. Airflow
(Vin = 18, airflow from Pin 1 to Pin 4 on PCB, with Baseplate)

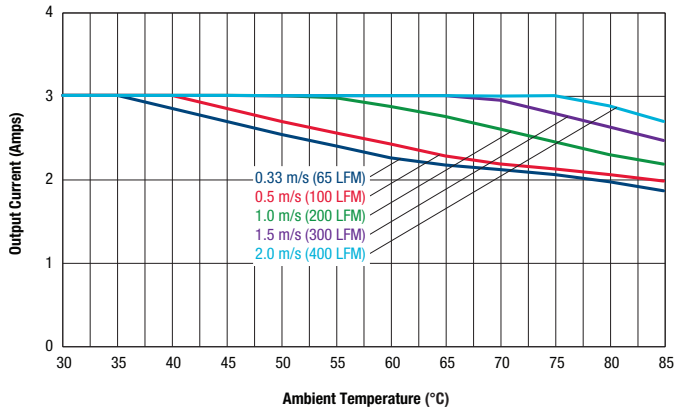

Maximum Current Temperature Derating vs. Airflow
(Vin = 24V, airflow from from Pin 1 to Pin 4 on PCB, with baseplate)

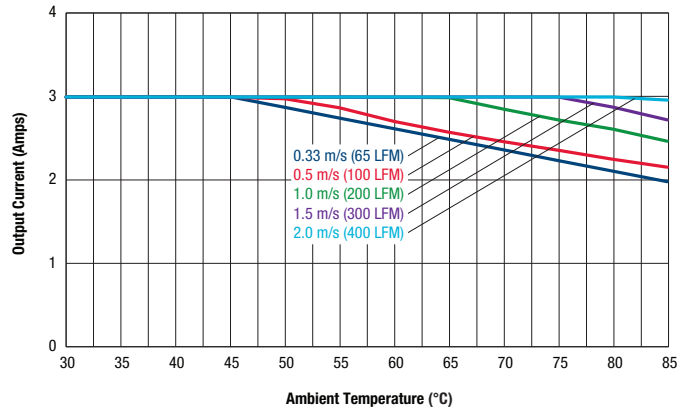

Maximum Current Temperature Derating vs. Airflow
(Vin = 36, airflow from Pin 1 to Pin 4 on PCB, with Baseplate)

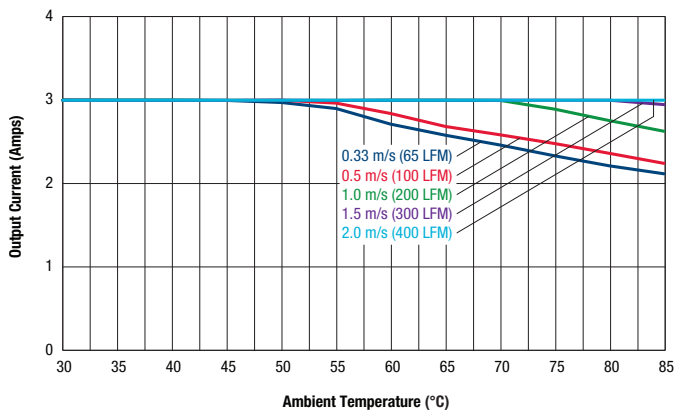

Maximum Current Temperature Derating vs. Airflow
(Vin = 48V, airflow from from Pin 1 to Pin 4 on PCB, with baseplate)

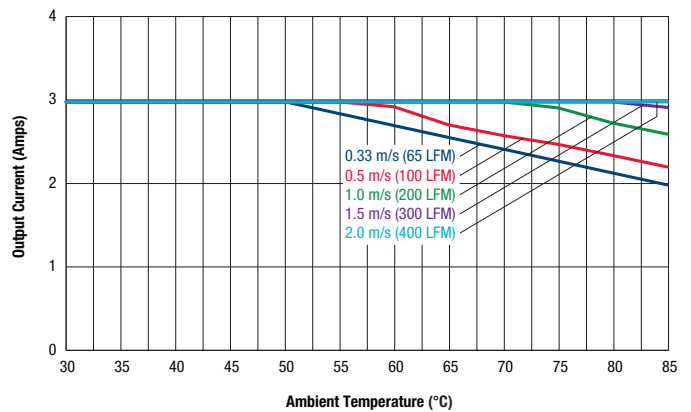

Maximum Current Temperature Derating vs. Airflow
(Vin = 60, airflow from Pin 1 to Pin 4 on PCB, with Baseplate)

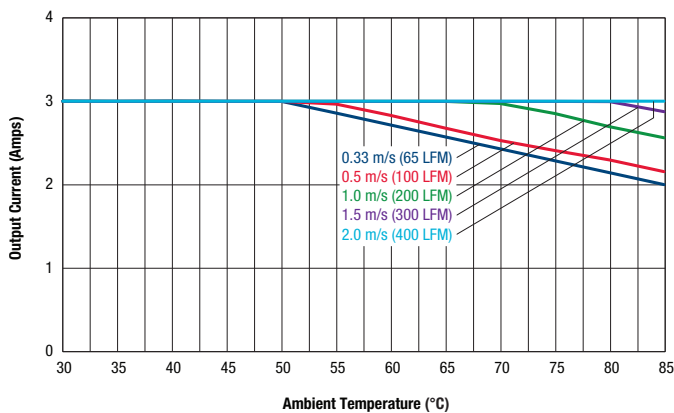

Maximum Current Temperature Derating vs. Airflow
(Vin = 72V, airflow from from Pin 1 to Pin 4 on PCB, with baseplate)

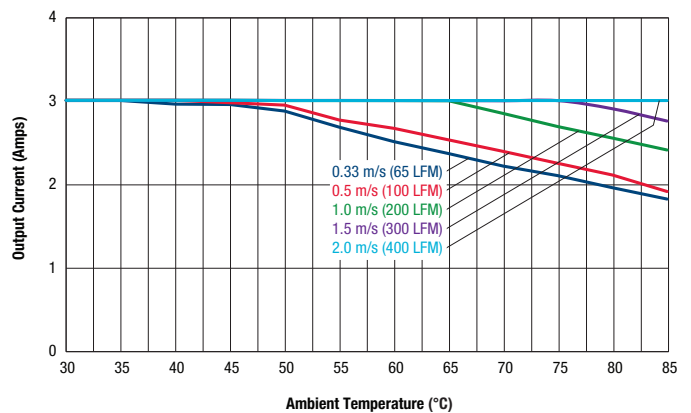

TYPICAL PERFORMANCE DATA

Efficiency vs Line Voltage and Load Current @ +25°C

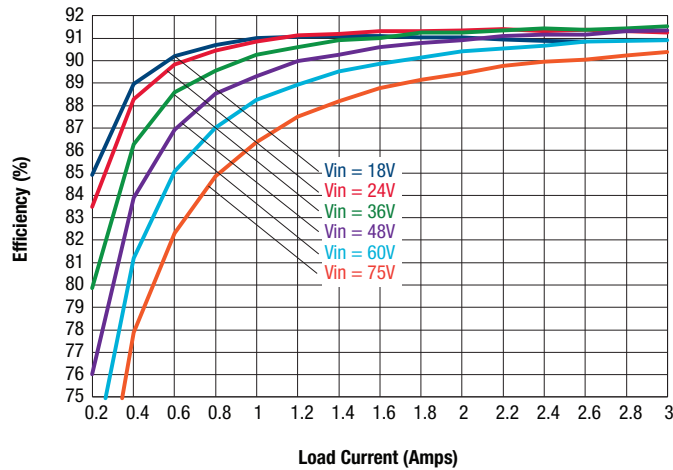

Startup Delay (Vin=48V, Iout=3A, Ta=+25°C) Trace 1=Vin, Trace 4=Vout.

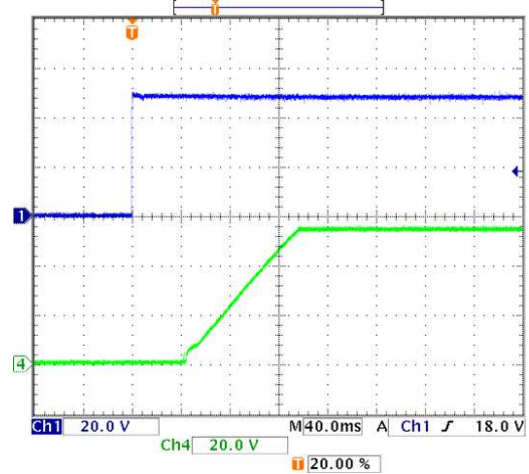

On/Off Enable Delay (Vin=48V, Iout=3A, Ta=+25°C) Trace 1=Enable, Trace 4=Vout.

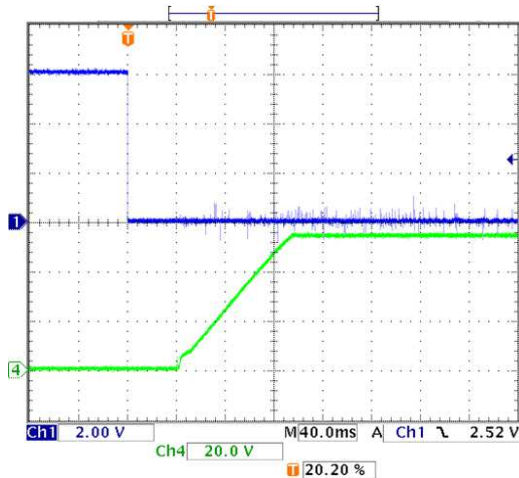

Stepload Transient Response (Vin=48V, Iout =50-75-50%, Ta=+25°C)

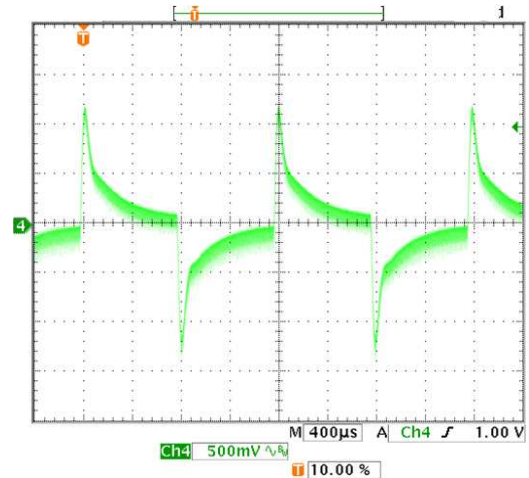

Output Ripple and Noise (Vin=48V, Vout=nom, Iout=0A, Load=1uF, Ta=+25°C)

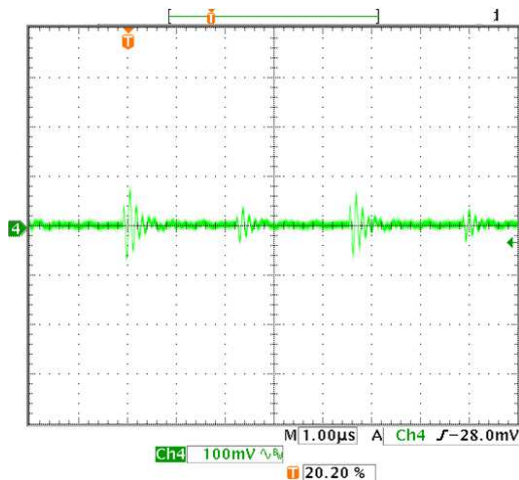

Output Ripple and Noise (Vin=48V, Vout=nom, Iout=3A, Load=1uF, Ta=+25°C)

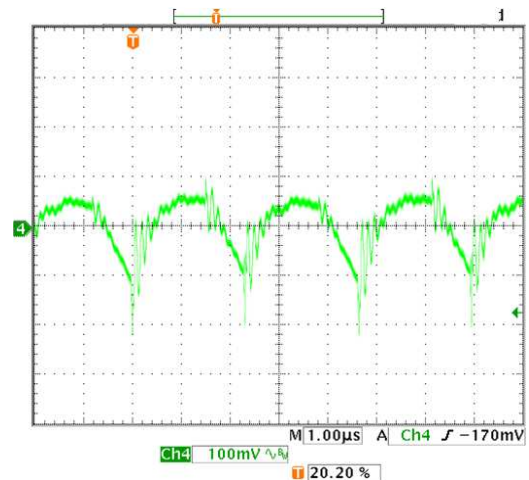

TYPICAL PERFORMANCE DATA

Thermal image with hot spot at 2.9A with 25°C ambient temperature. Natural convection is used with no forced airflow. Identifiable and recommended maximum value to be verified in application. Vin=48V, T3 and Q12 max temp=128°C/IPC9592 guidelines.

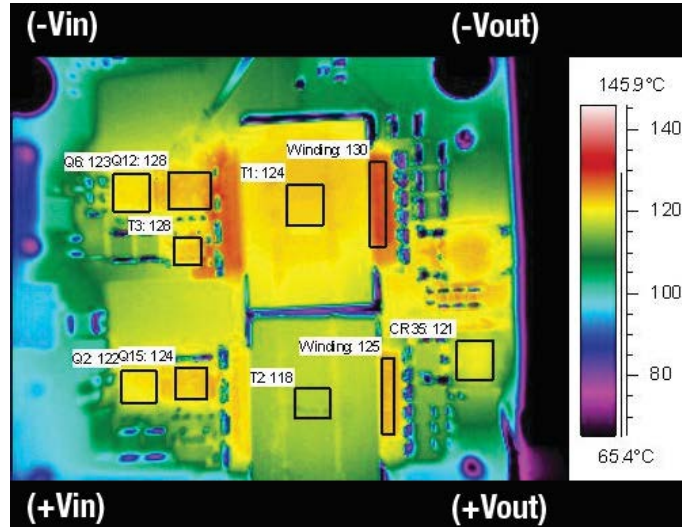

MECHANICAL SPECIFICATIONS – OPEN FRAME

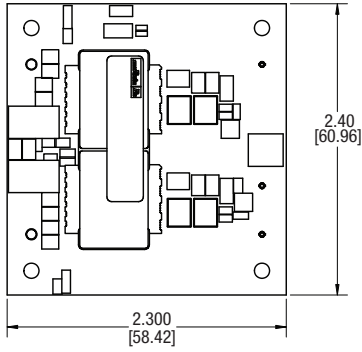

TOP VIEW

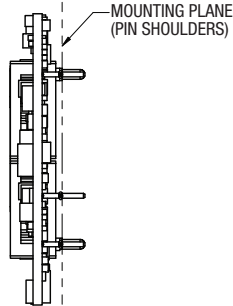

SIDE VIEW

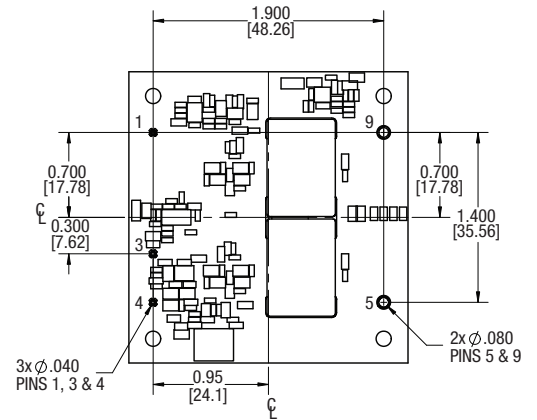

BOTTOM VIEW

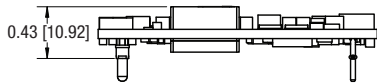

END VIEW

Dimensions are in inches (mm shown for ref. only).

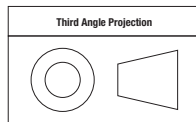

Tolerances (unless otherwise specified):
 .XX ± 0.02 (0.5)
 .XXX ± 0.010 (0.25)
 Angles ± 2°

Components are shown for reference only.

INPUT/OUTPUT CONNECTIONS

| Pin | Function |
|-----|-----------------|
| 1 | Negative Input |
| 2 | Omitted |
| 3 | Remote On/Off |
| 4 | Positive Input |
| 5 | Positive Output |
| 6 | Omitted |
| 7 | Omitted |
| 8 | Omitted |
| 9 | Negative Output |

MATERIAL:

FINISH: (ALL PINS)

.080 PINS: COPPER ALLOY

.040 PINS: COPPER ALLOY

FINISH: (ALL PINS)

GOLD (5u"MIN) OVER NICKEL (50u" MIN)

MECHANICAL SPECIFICATIONS – WITH BASEPLATE

Dimensions are in inches (mm shown for ref. only).

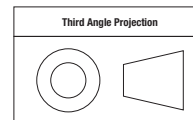

Tolerances (unless otherwise specified):
 .XX ± 0.02 (0.5)
 .XXX ± 0.010 (0.25)
 Angles ± 2°

Components are shown for reference only.

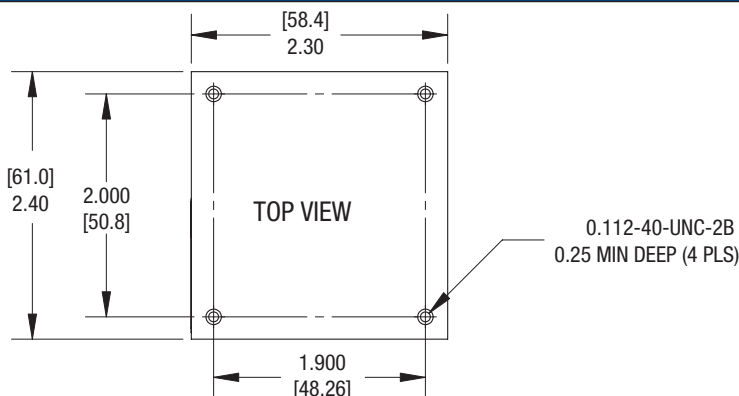

0.112-40-UNC-2B
0.25 MIN DEEP (4 PLS)

END VIEW

ALUMINUM BASEPLATE

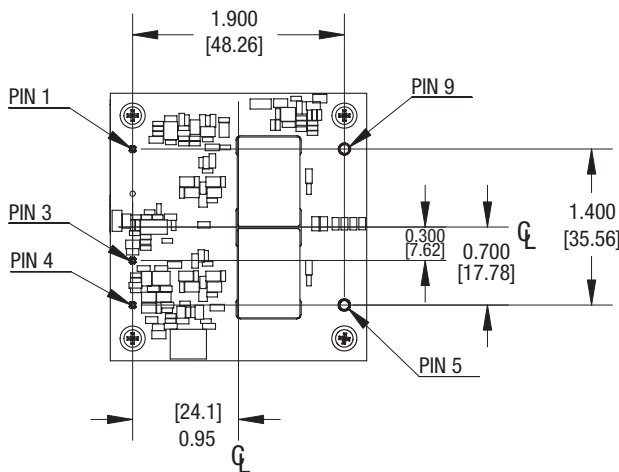
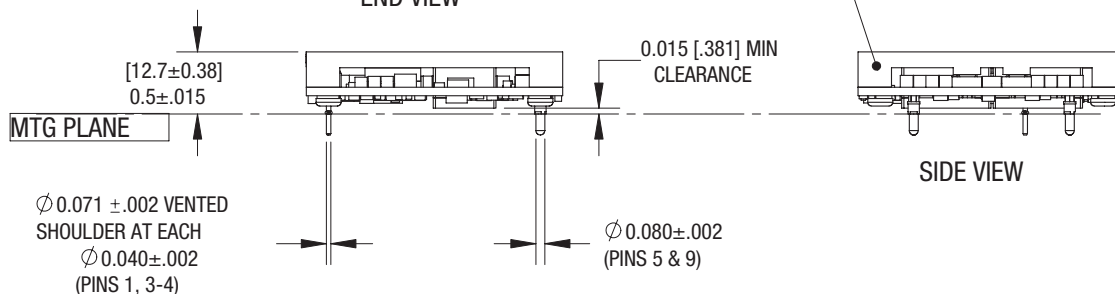

INPUT/OUTPUT CONNECTIONS

| Pin | Function |
|-----|-----------------|
| 1 | Negative Input |
| 2 | Omitted |
| 3 | Remote On/Off |
| 4 | Positive Input |
| 5 | Positive Output |
| 6 | Omitted |
| 7 | Omitted |
| 8 | Omitted |
| 9 | Negative Output |

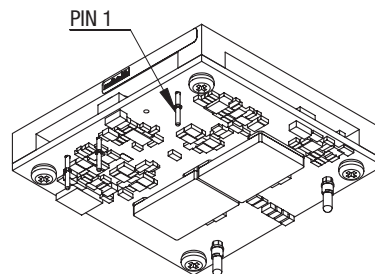

ISOMETRIC VIEW

MATERIAL:

- Ø .040 PINS: COPPER ALLOY
- Ø .080 PINS: COPPER ALLOY

FINISH: (ALL PINS)

GOLD (5u"MIN) OVER NICKEL (50u" MIN)

RECOMMENDED FOOTPRINT (VIEW THROUGH CONVERTER)

TOP VIEW

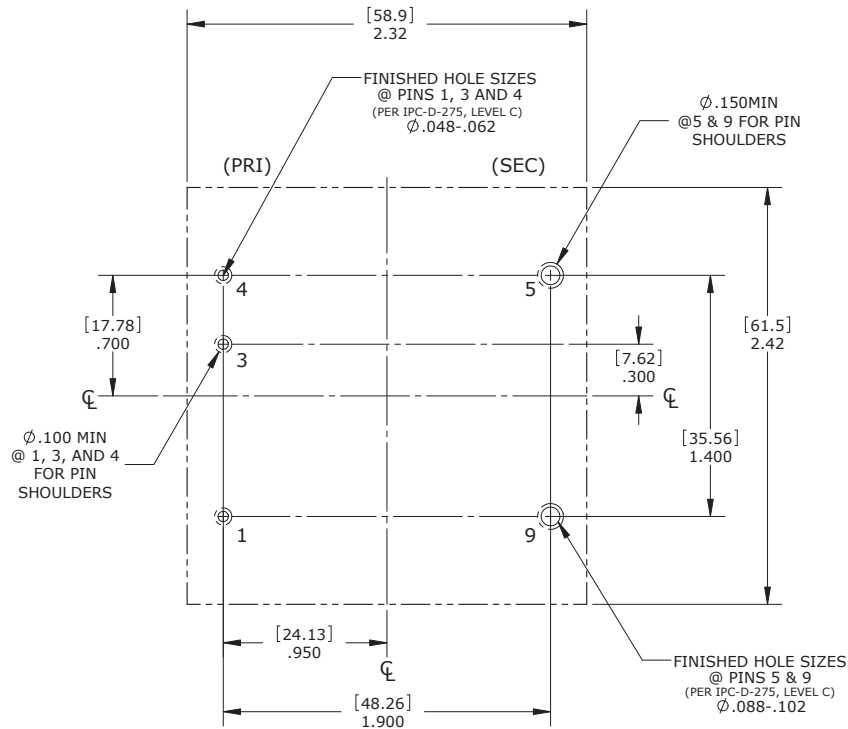

Dimensions are in inches (mm shown for ref. only).

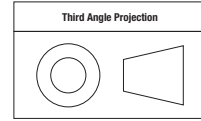

Tolerances (unless otherwise specified):
XX ± 0.02 (0.5)
.XXX ± 0.010 (0.25)
Angles ± 2°

Components are shown for reference only.

STANDARD PACKAGING

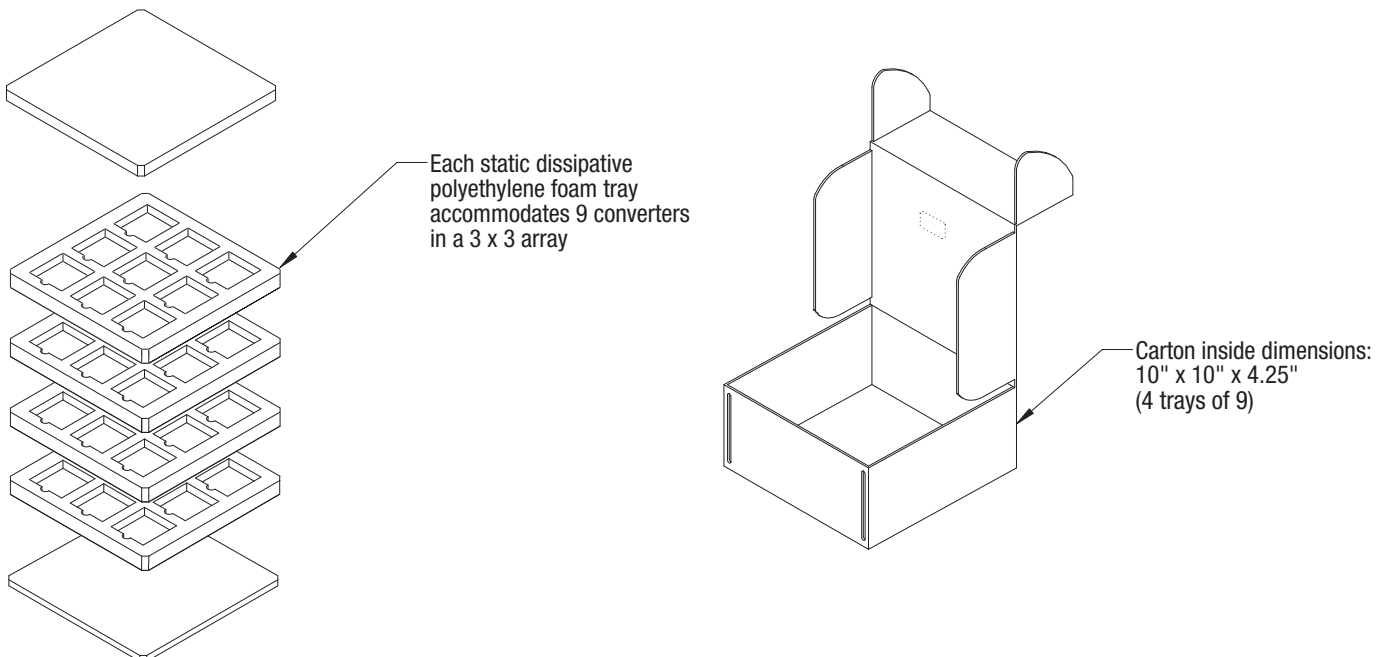

TECHNICAL NOTES

Input Fusing

Certain applications and/or safety agencies may require fuses at the inputs of power conversion components. Fuses should also be used when there is the possibility of sustained input voltage reversal which is not current-limited. For greatest safety, we recommend a fast blow fuse installed in the ungrounded input supply line.

The installer must observe all relevant safety standards and regulations. For safety agency approvals, install the converter in compliance with the end-user safety standard, i.e. IEC/EN/UL 60950-1.

Input Reverse-Polarity Protection

If the input voltage polarity is reversed, an internal diode will become forward biased and likely draw excessive current from the power source. If this source is not current-limited or the circuit appropriately fused, it could cause permanent damage to the converter.

Input Under-Voltage Shutdown and Start-Up Threshold

Under normal start-up conditions, converters will not begin to regulate properly until the ramping-up input voltage exceeds and remains at the Start-Up Threshold Voltage (see Specifications). Once operating, converters will not turn off until the input voltage drops below the Under-Voltage Shutdown Limit. Subsequent restart will not occur until the input voltage rises again above the Start-Up Threshold. This built-in hysteresis prevents any unstable on/off operation at a single input voltage.

Users should be aware however of input sources near the Under-Voltage Shutdown whose voltage decays as input current is consumed (such as capacitor inputs), the converter shuts off and then restarts as the external capacitor recharges. Such situations could oscillate. To prevent this, make sure the operating input voltage is well above the UV Shutdown voltage AT ALL TIMES.

Start-Up Time

Assuming that the output current is set at the rated maximum, the Vin to Vout Start-Up Time (see Specifications) is the time interval between the point when the ramping input voltage crosses the Start-Up Threshold and the fully loaded regulated output voltage enters and remains within its specified accuracy band. Actual measured times will vary with input source impedance, external input capacitance, input voltage slew rate and final value of the input voltage as it appears at the converter.

These converters include a soft start circuit, which limits the duty cycle of the PWM controller at power up, thereby limiting the input inrush current.

The On/Off Remote Control interval from On command to Vout regulated assumes that the converter already has its input voltage stabilized above the Start-Up Threshold before the On command. The interval is measured from the On command until the output enters and remains within its specified accuracy band. The specification assumes that the output is fully loaded at maximum rated current. Similar conditions apply to the On to Vout regulated specification such as external load capacitance and soft start circuitry.

Input Source Impedance

These converters will operate to specifications without external components, assuming that the source voltage has very low impedance and reasonable input voltage regulation. Since real-world voltage sources have finite impedance, performance is improved by adding external filter components.

Sometimes only a small ceramic capacitor is sufficient. Since it is difficult to totally characterize all applications, some experimentation may be needed. Note that external input capacitors must accept high speed switching currents.

Because of the switching nature of DC/DC converters, the input of these converters must be driven from a source with both low AC impedance and adequate DC input regulation. Performance will degrade with increasing input inductance. Excessive input inductance may inhibit operation. The DC input regulation specifies that the input voltage, once operating, must never degrade below the Shut-Down Threshold under all load conditions. Be sure to use adequate trace sizes and mount components close to the converter.

I/O Filtering, Input Ripple Current and Output Noise

All models in this converter series are tested and specified for input reflected ripple current and output noise using designated external input/output components, circuits and layout as shown in the figures below. External input capacitors (Cin in the figure) serve primarily as energy storage elements, minimizing line voltage variations caused by transient IR drops in the input conductors. Users should select input capacitors for bulk capacitance (at appropriate frequencies), low ESR and high RMS ripple current ratings. In the figure below, the Cbus and Lbus components simulate a typical DC voltage bus. Your specific system configuration may require additional considerations. Please note that the values of Cin, Lbus and Cbus will vary according to the specific converter model.

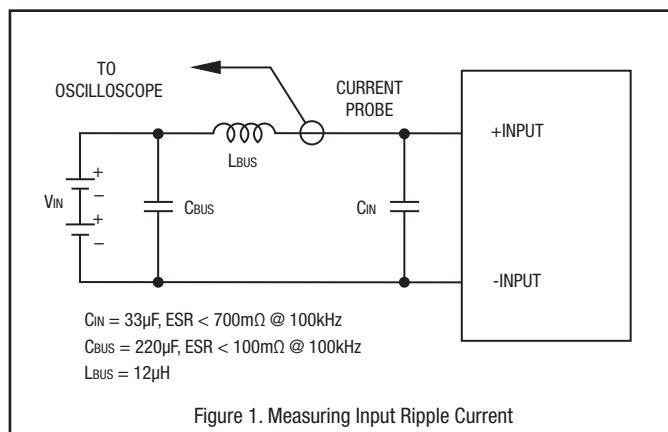

In critical applications, output ripple and noise (also referred to as periodic and random deviations or PARD) may be reduced by adding filter elements such as multiple external capacitors. Be sure to calculate component temperature rise from reflected AC current dissipated inside capacitor ESR. Our Application Engineers can recommend potential solutions.

Floating Outputs

Since these are isolated DC/DC converters, their outputs are “floating” with respect to their input. The essential feature of such isolation is ideal ZERO CURRENT FLOW between input and output. Real-world converters however do exhibit tiny leakage currents between input and output (see Specifications). These leakages consist of both an AC stray capacitance coupling component and a DC leakage resistance. When using the isolation feature, do not allow the isolation voltage to exceed specifications. Otherwise the converter may be damaged. Designers will normally use the negative output (-Output) as the ground return of the load circuit. You can however use the positive output (+Output) as the ground return to effectively reverse the output polarity.

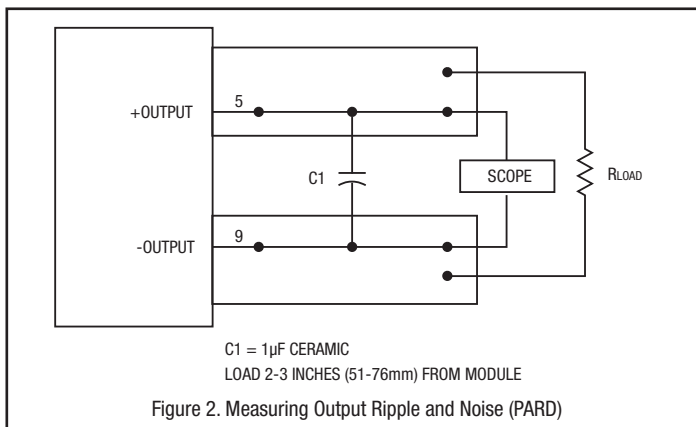

Thermal Shutdown

To prevent many over temperature problems and damage, these converters include thermal shutdown circuitry. If environmental conditions cause the temperature of the DC/DC's to rise above the Operating Temperature Range up to the shutdown temperature, an on-board electronic temperature sensor will power down the unit. When the temperature decreases below the turn-on threshold, the converter will automatically restart. There is a small amount of hysteresis to prevent rapid on/off cycling. The temperature sensor is typically located adjacent to the switching controller, approximately in the center of the unit. See the Performance and Functional Specifications.

CAUTION: If you operate too close to the thermal limits, the converter may shut down suddenly without warning. Be sure to thoroughly test your application to avoid unplanned thermal shutdown.

Temperature Derating Curves

The graphs in this data sheet illustrate typical operation under a variety of conditions. The derating curves show the maximum continuous ambient air temperature and decreasing maximum output current which is acceptable under increasing forced airflow measured in Linear Feet per Minute ("LFM"). Note that these are AVERAGE measurements. The converter will accept brief increases in temperature and/or current or reduced airflow as long as the average is not exceeded.

Note that the temperatures are of the ambient airflow, not the converter itself which is obviously running at higher temperature than the outside air. Also note that very low flow rates are similar to "natural convection," that is, not using fan-forced airflow.

Murata Power Solutions makes characterization measurements in a closed loop wind tunnel with measured airflow. We use both thermocouples and an infrared camera system to observe thermal performance. If in doubt, contact Murata Power Solutions to discuss placement and measurement techniques of suggested temperature sensors.

CAUTION: If you routinely or accidentally exceed these Derating guidelines, the converter may have an unplanned Over Temperature shut down. Also, these graphs are all collected at slightly above Sea Level altitude. Be sure to reduce the derating for higher density altitude.

Output Overvoltage Protection

This converter monitors its output voltage for an over-voltage condition using an on-board electronic comparator. If the output exceeds OVP limits, the

sensing circuit will power down the unit, and the output voltage will decrease. After a time-out period, the PWM will automatically attempt to restart, causing the output voltage to ramp up to its rated value. It is not necessary to power down and reset the converter for this automatic OVP-recovery restart.

If the fault condition persists and the output voltage climbs to excessive levels, the OVP circuitry will initiate another shutdown cycle. This on/off cycling is referred to as "hiccup" mode.

Output Fusing

The converter is extensively protected against current, voltage and temperature extremes. However your output application circuit may need additional protection. In the extremely unlikely event of output circuit failure, excessive voltage could be applied to your circuit. Consider using an appropriate fuse in series with the output.

Output Current Limiting

As soon as the output current increases to its maximum rated value, the DC/DC converter will enter a power-limiting mode. The output voltage will decrease proportionally with increases in output current, thereby maintaining a somewhat constant power output. This is commonly referred to as power limiting.

Current limiting inception is defined as the point at which full power falls below the rated tolerance. See the Performance/Functional Specifications. Note particularly that the output current may briefly rise above its rated value. This enhances reliability and continued operation of your application. If the output current is too high, the converter will enter the short circuit condition.

Output Short Circuit Condition

When a converter is in power-limit mode, the output voltage will drop as the output current demand increases. If the output voltage drops too low, the magnetically coupled voltage used to develop primary side voltages will also drop, thereby shutting down the PWM controller. Following a time-out period, the PWM will restart, causing the output voltage to begin ramping up to its appropriate value. If the short-circuit condition persists, another shutdown cycle will initiate. This on/off cycling is called "hiccup mode". The hiccup cycling reduces the average output current, thereby preventing excessive internal temperatures. A short circuit can be tolerated indefinitely.

Remote On/Off Control

Negative: Optional negative-logic devices are on (enabled) when the On/Off is grounded or brought to within a low voltage (see Specifications) with respect to $-V_{in}$. The device is off (disabled) when the On/Off is pulled high to $+V_{in}$ with respect to $-V_{in}$.

Dynamic control of the On/Off function should be able to sink appropriate signal current when brought low and withstand appropriate voltage when brought high. Be aware too that there is a finite time in milliseconds (see Specifications) between the time of On/Off Control activation and stable, regulated output. This time will vary slightly with output load type and current and input conditions.

There are two CAUTIONs for the On/Off Control:

CAUTION: While it is possible to control the On/Off with external logic if you carefully observe the voltage levels, the preferred circuit is either an open drain/open collector transistor or a relay (which can thereupon be controlled by logic).

CAUTION: Do not apply voltages to the On/Off pin when there is no input voltage. Otherwise the converter may be permanently damaged.

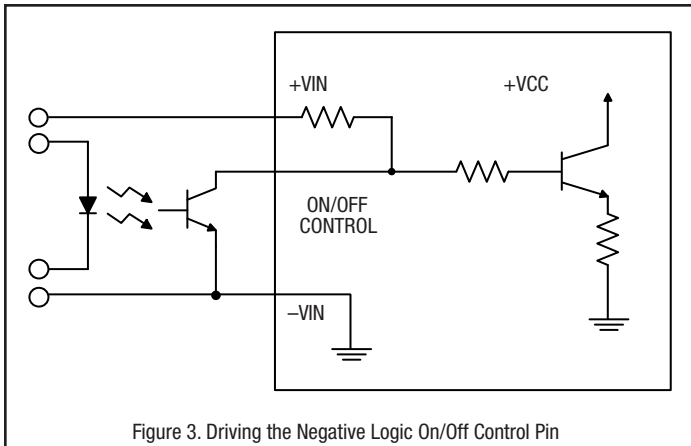

Figure 3. Driving the Negative Logic On/Off Control Pin

Soldering Guidelines

Murata Power Solutions recommends the specifications below when installing these converters. These specifications vary depending on the solder type. Exceeding these specifications may cause damage to the product. Be cautious when there is high atmospheric humidity. We strongly recommend a mild pre-bake (100° C. for 30 minutes). Your production environment may differ; therefore please thoroughly review these guidelines with your process engineers.

| Wave Solder Operations for through-hole mounted products (THMT) | | | |
|---|-----------|-----------------------------|-----------|
| For Sn/Ag/Cu based solders: | | For Sn/Pb based solders: | |
| Maximum Preheat Temperature | 115° C. | Maximum Preheat Temperature | 105° C. |
| Maximum Pot Temperature | 270° C. | Maximum Pot Temperature | 250° C. |
| Maximum Solder Dwell Time | 7 seconds | Maximum Solder Dwell Time | 6 seconds |

Power Over Ethernet (PoE)

Power over Ethernet (PoE) supports the implementation of the IEEE 802.3af and IEEE 802.3at standards; this implementation allows both data and electrical power to pass over a copper Ethernet LAN cable. PoE permits electric power, along with data, to be passed over a copper Ethernet LAN cable. Powered devices, such as voice-over-IP telephones, wireless access points, video cameras, and point-of-sale devices, that support PoE can receive power safely from the access ports that are used to connect personal computers to the network. IEEE 802.3at increases the amount of power to 30W. The PoE standard provides support for legacy PoE devices. An IEEE 802.af powered device can operate normally when connected to IEEE 802.at power sourcing equipment.

| Standard | Class | Maximum Power delivered by PoE port | Power range of powered device |
|---|-------|-------------------------------------|-------------------------------|
| IEEE 802.3af (PoE) and IEEE 802.3at (PoE +) | 0 | 15.4 W | 0.44 through 12.95 W |
| | 1 | 4 W | 0.44 through 3.84 W |
| | 2 | 7.0 W | 3.84 through 6.49 W |
| | 3 | 15.4 W | 6.49 through 12.95 W |
| IEEE 802.3at (PoE+) | 4 | 30.0 W | 12.95 through 25.5 W |

Table 1. Class of Powered Device and Power Levels

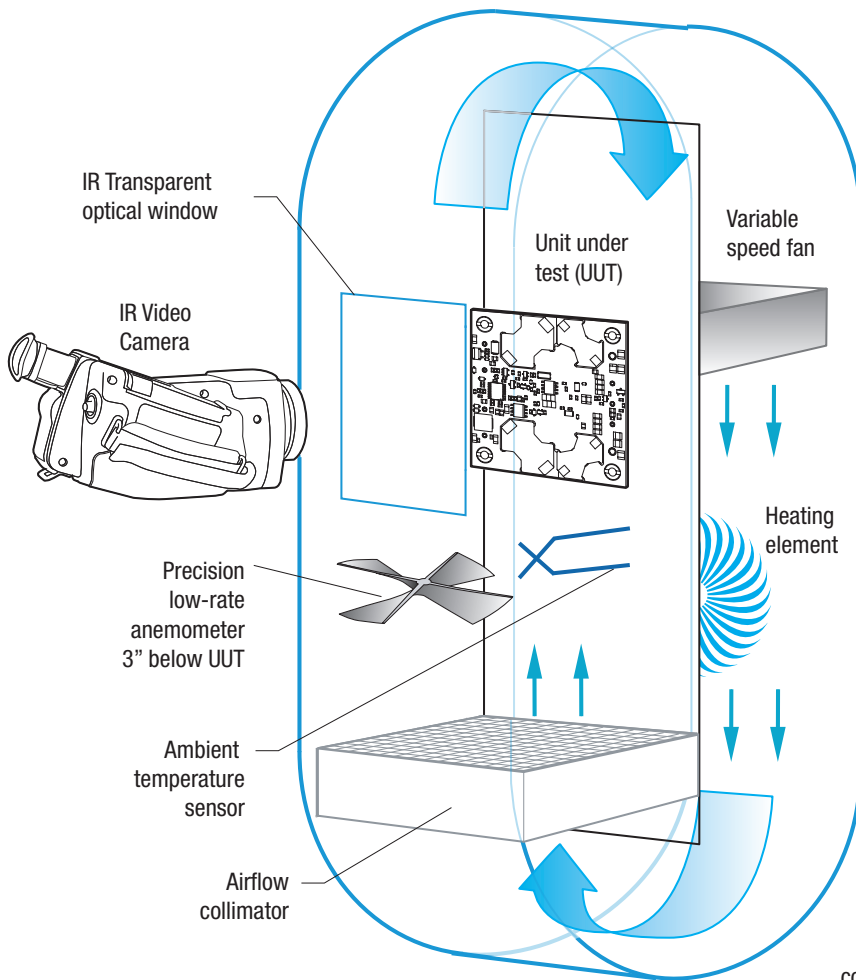

Figure 4. Vertical Wind Tunnel

Vertical Wind Tunnel

Murata Power Solutions employs a computer controlled custom-designed closed loop vertical wind tunnel, infrared video camera system, and test instrumentation for accurate airflow and heat dissipation analysis of power products. The system includes a precision low flow-rate anemometer, variable speed fan, power supply input and load controls, temperature gauges, and adjustable heating element.

The IR camera monitors the thermal performance of the Unit Under Test (UUT) under static steady-state conditions. A special optical port is used which is transparent to infrared wavelengths.

Both through-hole and surface mount converters are soldered down to a host carrier board for realistic heat absorption and spreading. Both longitudinal and transverse airflow studies are possible by rotation of this carrier board since there are often significant differences in the heat dissipation in the two airflow directions. The combination of adjustable airflow, adjustable ambient heat, and adjustable Input/Output currents and voltages mean that a very wide range of measurement conditions can be studied.

The collimator reduces the amount of turbulence adjacent to the UUT by minimizing airflow turbulence. Such turbulence influences the effective heat transfer characteristics and gives false readings. Excess turbulence removes more heat from some surfaces and less heat from others, possibly causing uneven overheating.

Both sides of the UUT are studied since there are different thermal gradients on each side. The adjustable heating element and fan, built-in temperature gauges, and no-contact IR camera mean that power supplies are tested in real-world conditions.

