



Chipsmall Limited consists of a professional team with an average of over 10 year of expertise in the distribution of electronic components. Based in Hongkong, we have already established firm and mutual-benefit business relationships with customers from,Europe,America and south Asia,supplying obsolete and hard-to-find components to meet their specific needs.

With the principle of "Quality Parts,Customers Priority,Honest Operation,and Considerate Service",our business mainly focus on the distribution of electronic components. Line cards we deal with include Microchip,ALPS,ROHM,Xilinx,Pulse,ON,Everlight and Freescale. Main products comprise IC,Modules,Potentiometer,IC Socket,Relay,Connector.Our parts cover such applications as commercial,industrial, and automotives areas.

We are looking forward to setting up business relationship with you and hope to provide you with the best service and solution. Let us make a better world for our industry!



Contact us

Tel: +86-755-8981 8866 Fax: +86-755-8427 6832

Email & Skype: info@chipsmall.com Web: www.chipsmall.com

Address: A1208, Overseas Decoration Building, #122 Zhenhua RD., Futian, Shenzhen, China





EMIF10-LCD01F2

IPAD™

10 line EMI filter and ESD protection

Main product characteristics:

Where EMI filtering in ESD sensitive equipment is required :

- LCD for Mobile phones
- Computers and printers
- Communication systems
- MCU Boards

Description

The EMIF10-LCD01F2 is a 10 line highly integrated device designed to suppress EMI/RFI noise in all systems subjected to electromagnetic interferences. The EMIF10 Flip-Chip packaging means the package size is equal to the die size.

This filter includes ESD protection circuitry, which prevents damage to the application when it is subjected to ESD surges up to 15 kV.

Benefits

- EMI symmetric (1/0) low-pass filter
- High efficiency in EMI filtering
- Very low PCB space consuming: < 6 mm²
- Lead free package
- Very thin package: 0.69 mm
- High efficiency in ESD suppression on input pins (IEC 61000-4-2 level 4)
- High reliability offered by monolithic integration
- High reducing of parasitic elements through integration and wafer level packaging.

Complies with following standards:

IEC 61000-4-2

level 4 input pins 15 kV (air discharge)
 8 kV (contact discharge)

MIL STD 883G - Method 3015-7 Class 3

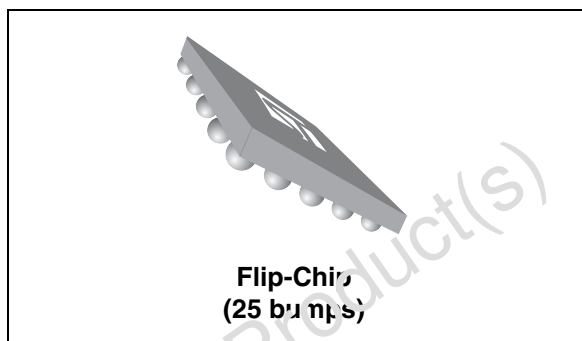

Order code

Part Number	Marking
EMIF10-LCD01F2	FL

Figure 1. Pin Configuration (bump side)

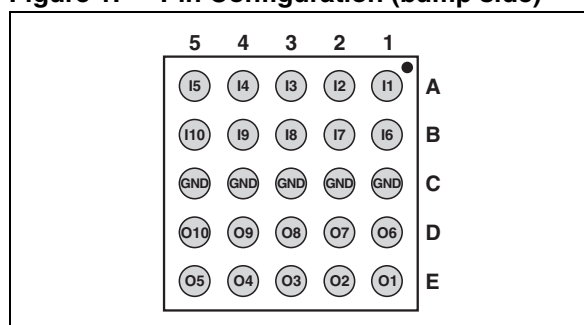
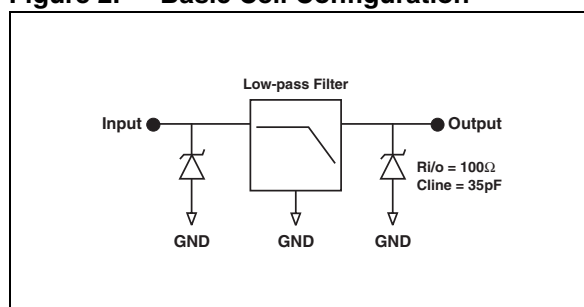

Figure 2. Basic Cell Configuration



TM: IPAD is a trademark of STMicroelectronics.

1 Characteristics

Table 1. Absolute Maximum Ratings ($T_{amb} = 25^{\circ}C$)

Symbol	Parameter	Value	Unit
T_j	Junction temperature	125	$^{\circ}C$
T_{op}	Operating temperature range	-40 to + 85	$^{\circ}C$
T_{stg}	Storage temperature range	-55 to +150	$^{\circ}C$

Table 2. Electrical Characteristics ($T_{amb} = 25^{\circ}C$)

Symbol	Parameter
V_{BR}	Breakdown voltage
I_{RM}	Leakage current @ V_{RM}
V_{RM}	Stand-off voltage
V_{CL}	Clamping voltage
R_d	Dynamic resistance
I_{PP}	Peak pulse current
$R_{I/O}$	Series resistance between Input and Output
C_{line}	Input capacitance per line

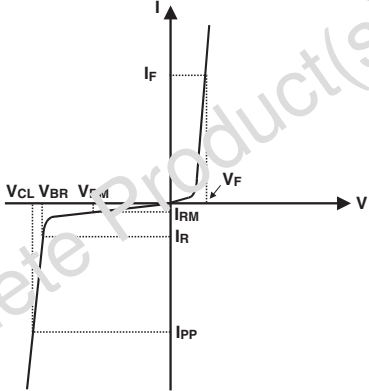

Symbol	Test conditions	Min.	Typ.	Max.	Unit
V_{BR}	$I_R = 1\text{ mA}$	6	8	10	V
I_{RM}	$V_{RM} = 3\text{ V}$			500	nA
$R_{I/O}$		90	100	110	Ω
C_{line}	@ 0 V bias		28	35	pF
Rt / Ft	Induced rise and fall time 10-90% at 26 MHz frequency (signal V = 1.9 V (Rt / Ft input 1 ns, 50 Ω impedance generator)		8 ⁽¹⁾		ns

1. guaranteed by design

Figure 3. S21(dB) attenuation measurement

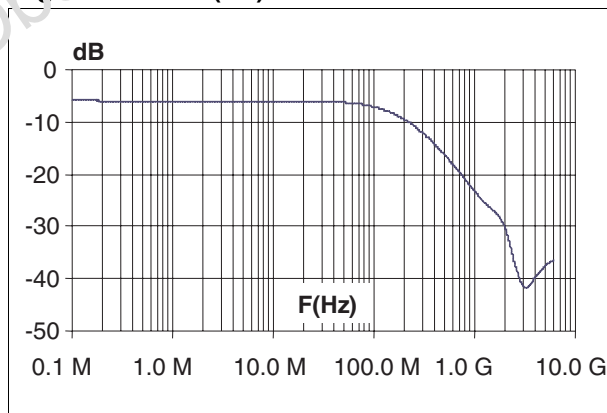

Figure 4. Analog cross talk measurement

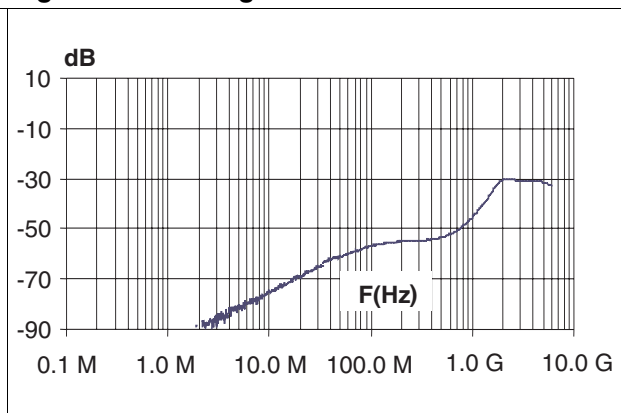

Figure 5. ESD response to IEC 61000-4-2 (+15 kV air discharge) on one input and on one output

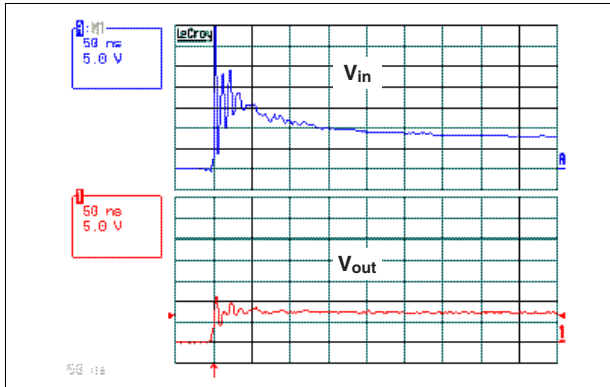

Figure 6. ESD response to IEC 61000-4-2 (-15 kV air discharge) on one input and on one output

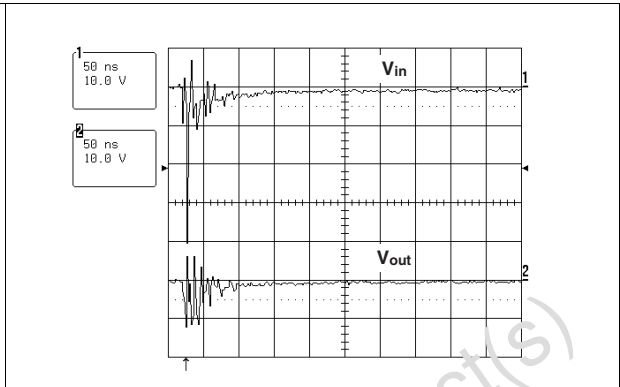

Figure 7. Line capacitance versus applied voltage

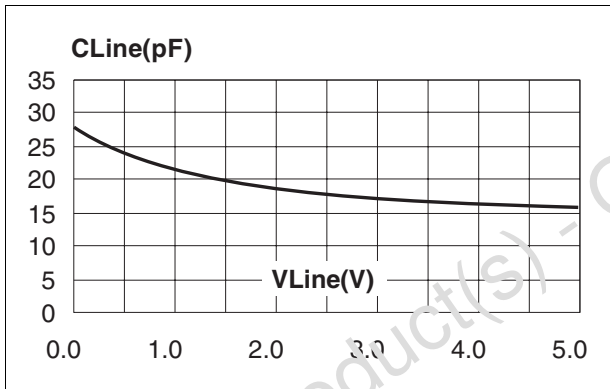

Figure 8. Rise time 10-90% measurements with 1.9 V signal at 26 MHz frequency (50 Ω generator)

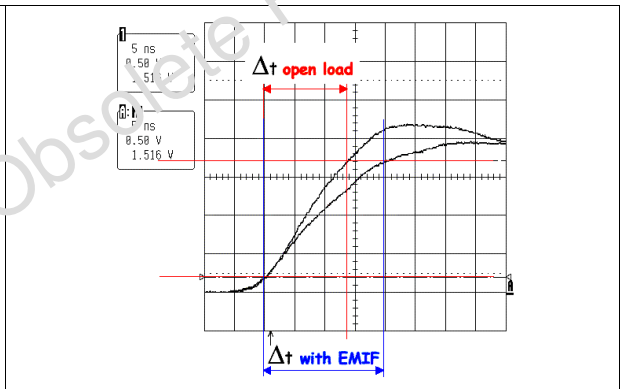

Figure 9. Fall time 10-90% measurements with 1.9 V signal at 26 MHz frequency (50 Ω generator)

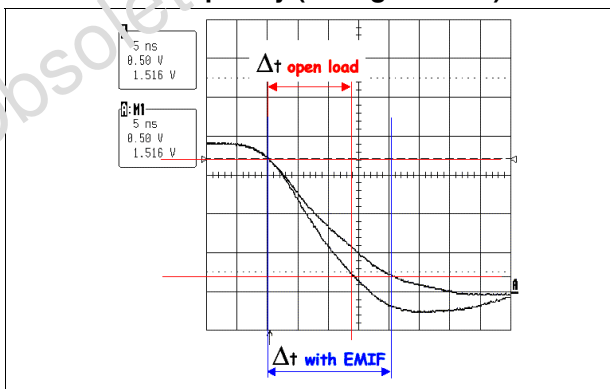

Figure 10. Aplac model

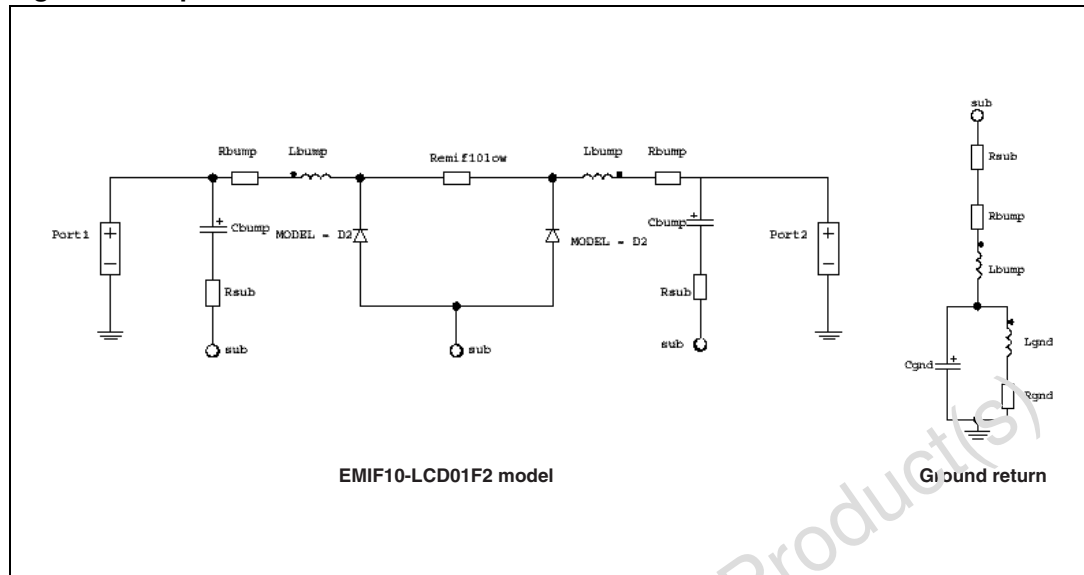
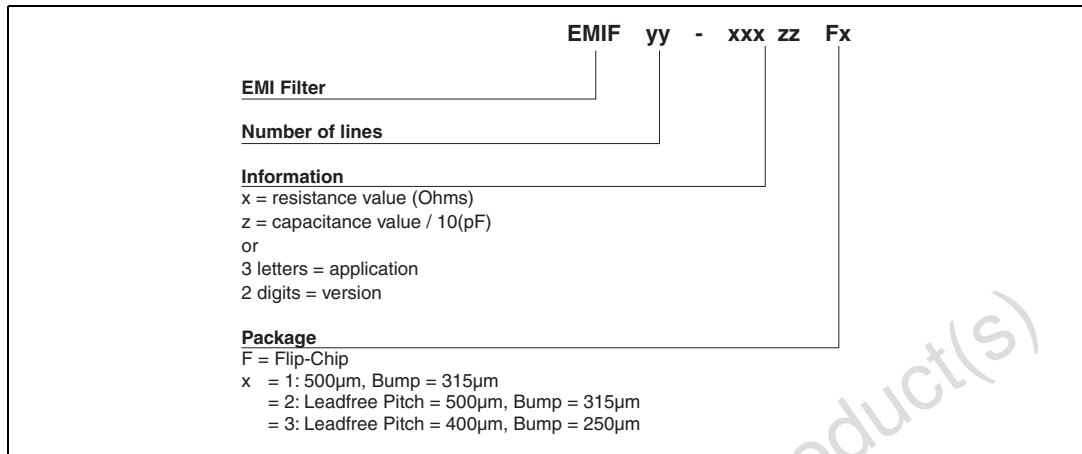

Figure 11. Aplac parameters

ZRZ structure
 aplacvar Remif10low 100
 aplacvar Cemif10flow 17.5pF
 Bumps
 aplacvar Lbump 50pH
 aplacvar Rbump 20m
 aplacvar Cbump 1.5pF
 Bulk
 aplacvar Rsub 100m
 Cnd connections
 aplacvar Rgnd 100m
 aplacvar Lgnd 200pH
 aplacvar Cgnd 0.15pF

BV = 7
 CJO = Cemif10low
 IBV = 1u
 IKF = 1000
 IS = 10f
 ISR = 100p
 N = 1
 M = 0.3333
 RS = 0.015
 VJ = 0.6
 TT = 50n

2 Ordering information scheme



3 Package information

Figure 12. Flip-Chip Dimensions

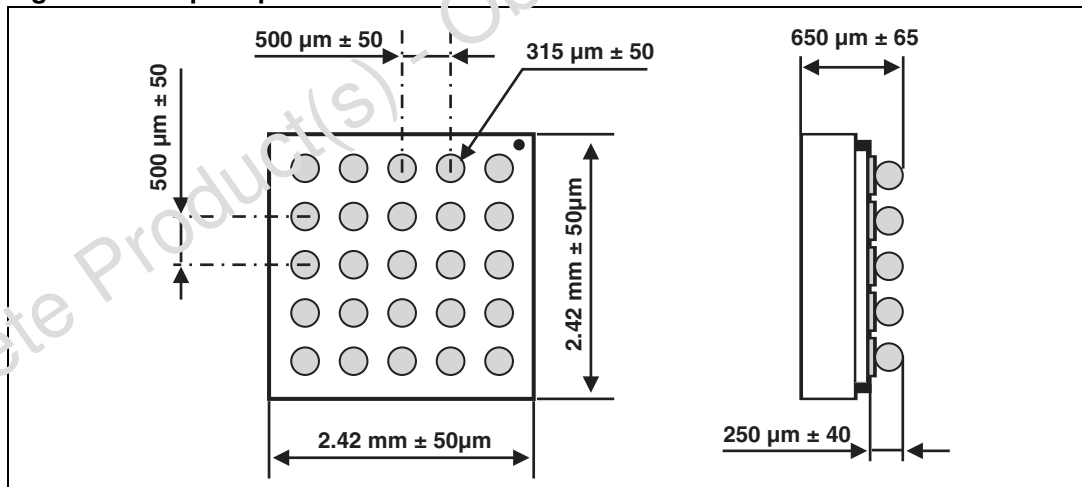

Figure 13. Marking

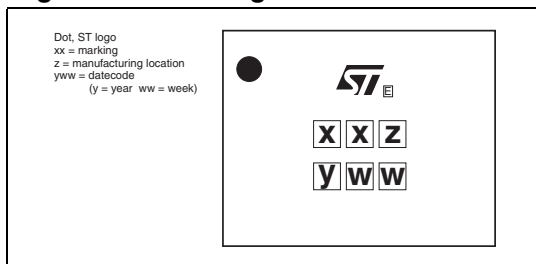

Figure 14. Footprint recommendation

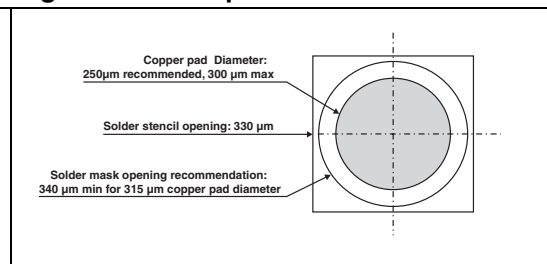
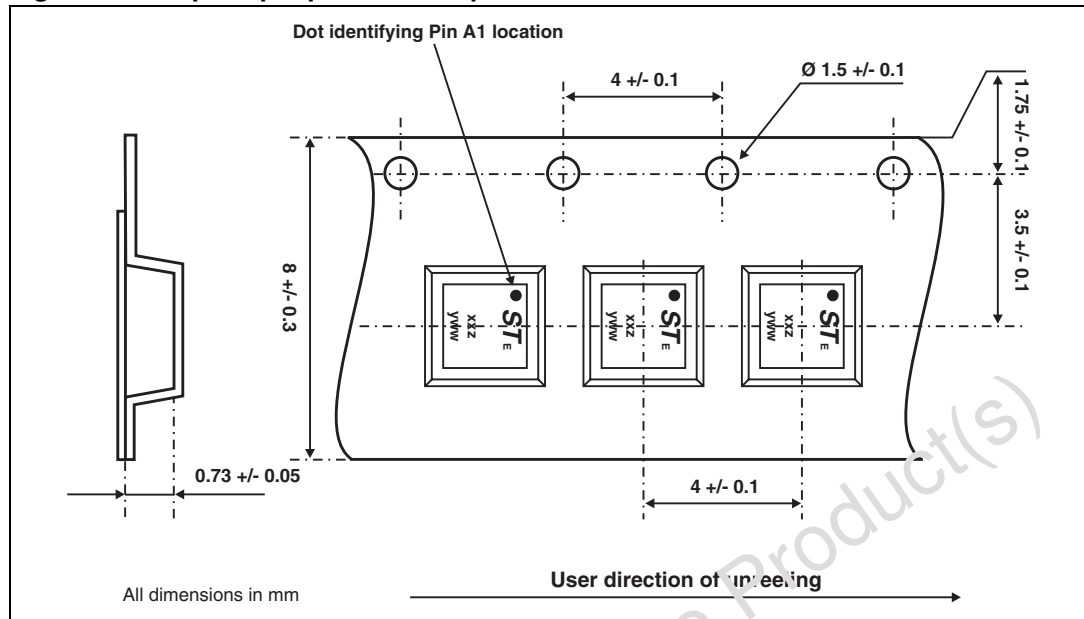

Figure 15. Flip-Chip tape and reel specification



In order to meet environmental requirements, ST offers these devices in ECOPACK® packages. These packages have a lead-free second level interconnect. The category of second level interconnect is marked on the package and on the inner box label, in compliance with JEDEC Standard JESD57. The maximum ratings related to soldering conditions are also marked on the inner box label. ECOPACK is an ST trademark. ECOPACK specifications are available at: www.st.com.

- Note: More packing information is available in the application notes:
 AN1235: "Flip-Chip: Package description and recommendations for use"
 AN1751: "EMI Filters: Recommendations and measurements"

4 Ordering information

Ordering code	Marking	Package	Weight	Base qty	Delivery mode
EMIF10-LCD01F2	FL	Flip-Chip	9.3 mg	5000	Tape and reel (7")

5 Revision history

Date	Revision	Changes
14-Feb-2005	1	Initial release.
17-Mar-2005	2	Capacitance C_{line} specification changed from 47 pF (typ) to 28 pF (typ) and 35 pF (max).
30-Jan-2007	3	Reformatted to current standards. Reduced die size and updated Figures 3 and 4.

Obsolete Product(s) - Obsolete Product(s)

Please Read Carefully:

Information in this document is provided solely in connection with ST products. STMicroelectronics NV and its subsidiaries ("ST") reserve the right to make changes, corrections, modifications or improvements, to this document, and the products and services described herein at any time, without notice.

All ST products are sold pursuant to ST's terms and conditions of sale.

Purchasers are solely responsible for the choice, selection and use of the ST products and services described herein, and ST assumes no liability whatsoever relating to the choice, selection or use of the ST products and services described herein.

No license, express or implied, by estoppel or otherwise, to any intellectual property rights is granted under this document. If any part of this document refers to any third party products or services it shall not be deemed a license grant by ST for the use of such third party products or services, or any intellectual property contained therein or considered as a warranty covering the use in any manner whatsoever of such third party products or services or any intellectual property contained therein.

UNLESS OTHERWISE SET FORTH IN ST'S TERMS AND CONDITIONS OF SALE ST DISCLAIMS ANY EXPRESS OR IMPLIED WARRANTY WITH RESPECT TO THE USE AND/OR SALE OF ST PRODUCTS INCLUDING WITHOUT LIMITATION IMPLIED WARRANTIES OF MERCHANTABILITY, FITNESS FOR A PARTICULAR PURPOSE (AND THEIR EQUIVALENTS UNDER THE LAWS OF ANY JURISDICTION), OR INFRINGEMENT OF ANY PATENT, COPYRIGHT OR OTHER INTELLECTUAL PROPERTY RIGHT.

UNLESS EXPRESSLY APPROVED IN WRITING BY AN AUTHORIZED ST REPRESENTATIVE, ST PRODUCTS ARE NOT RECOMMENDED, AUTHORIZED OR WARRANTED FOR USE IN MILITARY, AIR CRAFT, SPACE, LIFE SAVING, OR LIFE SUSTAINING APPLICATIONS, NOR IN PRODUCTS OR SYSTEMS WHERE FAILURE OR MALFUNCTION MAY RESULT IN PERSONAL INJURY, DEATH, OR SEVERE PROPERTY OR ENVIRONMENTAL DAMAGE. ST PRODUCTS WHICH ARE NOT SPECIFIED AS "AUTOMOTIVE GRADE" MAY ONLY BE USED IN AUTOMOTIVE APPLICATIONS AT USER'S OWN RISK.

Resale of ST products with provisions different from the statements and/or technical features set forth in this document shall immediately void any warranty granted by ST for the ST product or service described herein and shall not create or extend in any manner whatsoever, any liability of ST.

ST and the ST logo are trademarks or registered trademarks of ST in various countries.

Information in this document supersedes and replaces all information previously supplied.

The ST logo is a registered trademark of STMicroelectronics. All other names are the property of their respective owners.

© 2007 STMicroelectronics - All rights reserved

STMicroelectronics group of companies

Australia - Belgium - Brazil - Canada - China - Czech Republic - Finland - France - Germany - Hong Kong - India - Israel - Italy - Japan - Malaysia - Malta - Morocco - Singapore - Spain - Sweden - Switzerland - United Kingdom - United States of America

www.st.com