



Chipsmall Limited consists of a professional team with an average of over 10 year of expertise in the distribution of electronic components. Based in Hongkong, we have already established firm and mutual-benefit business relationships with customers from,Europe,America and south Asia,supplying obsolete and hard-to-find components to meet their specific needs.

With the principle of “Quality Parts,Customers Priority,Honest Operation,and Considerate Service”,our business mainly focus on the distribution of electronic components. Line cards we deal with include Microchip,ALPS,ROHM,Xilinx,Pulse,ON,Everlight and Freescale. Main products comprise IC,Modules,Potentiometer,IC Socket,Relay,Connector.Our parts cover such applications as commercial,industrial, and automotives areas.

We are looking forward to setting up business relationship with you and hope to provide you with the best service and solution. Let us make a better world for our industry!



Contact us

Tel: +86-755-8981 8866 Fax: +86-755-8427 6832

Email & Skype: info@chipsmall.com Web: www.chipsmall.com

Address: A1208, Overseas Decoration Building, #122 Zhenhua RD., Futian, Shenzhen, China



SPECIFICATION

- Part No. : **EMPCB.SMAFSTJ.B.HT**
- Product Name : SMA (F) Jack For Edge PCB Mount
- Feature : SMA(F) Jack
Straight Edge Mount PCB Jack
Frequency Range: 12.4GHz
Finish: Gold
Leg Length: 3.8mm
Total Length: 13.3mm
RoHS Compliant



1. Introduction

The EMPCB.SMAFSTJ.B.HT connector was designed to be mounted on a PCB edge. The edge mount configuration allows the connector to be easily slotted onto a PCB board; the maximum thickness of PCB that the connector can be used with is 0.8mm. The connector pin is directly soldered onto pads on the PCB. The connector is a standard SMA (F) Jack. The SMA connector is the most popular type connector for RF applications. Taoglas connectors are all RoHS compliant.

2. Specification

ELECTRICAL	
Impedance	50Ω
Frequency Range	0~12.4 GHz
Working Voltage	Max. 335 Vrms
Insulation Resistance	Min. 5000M ohms
MECHANICAL	
Connector Dimension	6.35 X 6.35 X13.3 mm
Max. Thickness PCB acceptable	0.8 mm
Connector Pin Diameter	0.76 mm
Connector Type	SMA (F) to PCB Edge Mounted
ENVIRONMENTAL	
RoHS compliant	
Operating Temperature	-40°C to +85°C

3. Connector Drawing

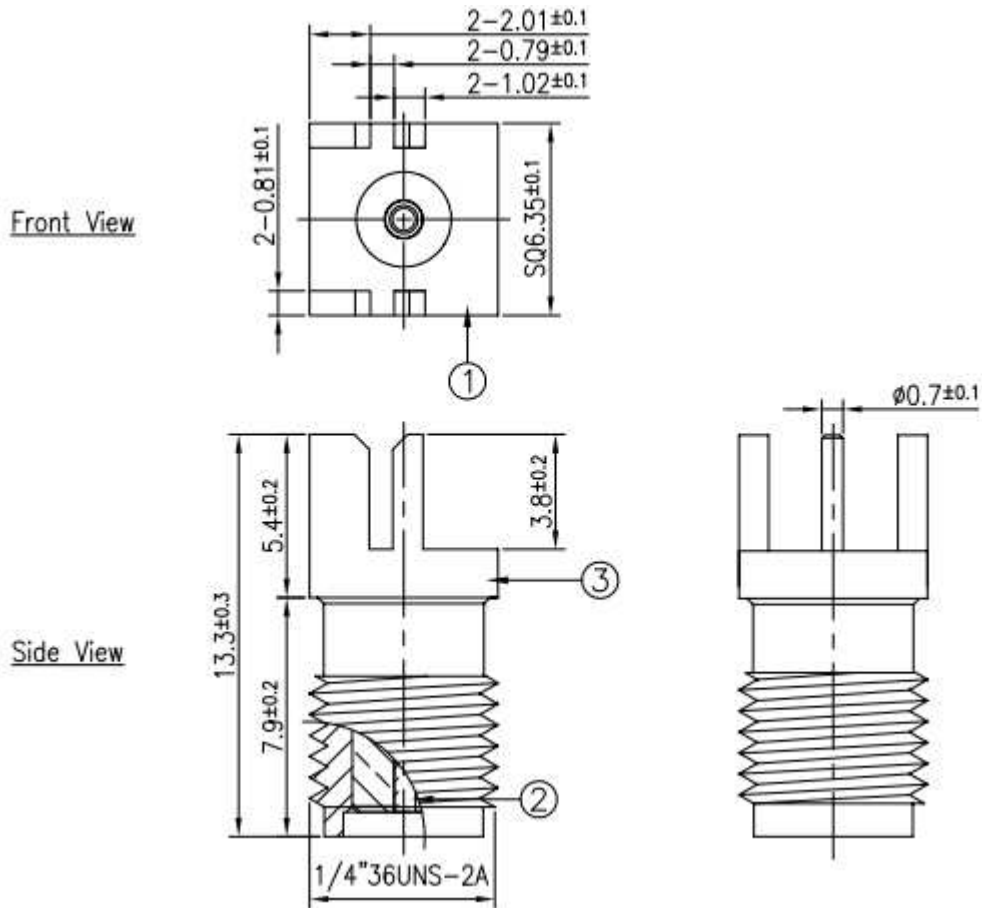

	Name	Material	Finish	QTY
1	Body	Brass	Gold	1
2	Pin	Brass	Gold	1
3	Insulator	Teflon	White	1

3.1 Footprint

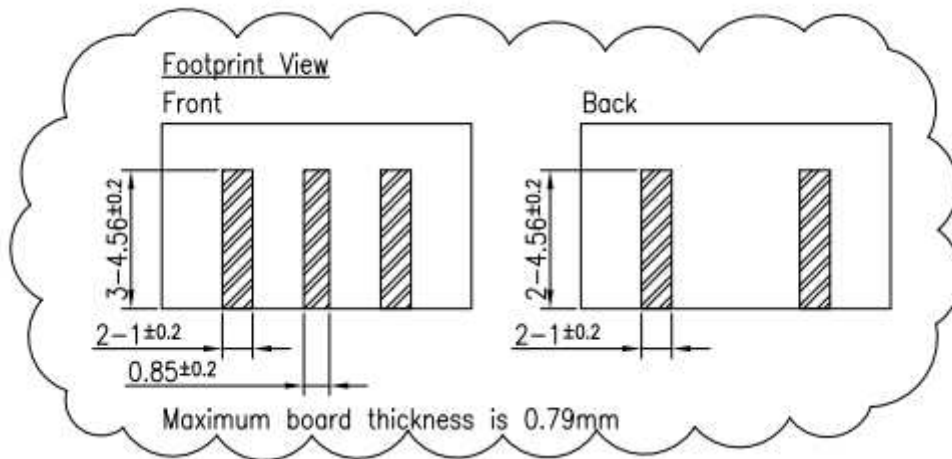

Taoglas makes no warranties based on the accuracy or completeness of the contents of this document and reserves the right to make changes to specifications and product descriptions at any time without notice. Taoglas reserves all rights to this document and the information contained herein. Reproduction, use or disclosure to third parties without express permission is strictly prohibited. Copyright © Taoglas Ltd.