



Chipsmall Limited consists of a professional team with an average of over 10 year of expertise in the distribution of electronic components. Based in Hongkong, we have already established firm and mutual-benefit business relationships with customers from,Europe,America and south Asia,supplying obsolete and hard-to-find components to meet their specific needs.

With the principle of “Quality Parts,Customers Priority,Honest Operation,and Considerate Service”,our business mainly focus on the distribution of electronic components. Line cards we deal with include Microchip,ALPS,ROHM,Xilinx,Pulse,ON,Everlight and Freescale. Main products comprise IC,Modules,Potentiometer,IC Socket,Relay,Connector.Our parts cover such applications as commercial,industrial, and automotives areas.

We are looking forward to setting up business relationship with you and hope to provide you with the best service and solution. Let us make a better world for our industry!



Contact us

Tel: +86-755-8981 8866 Fax: +86-755-8427 6832

Email & Skype: info@chipsmall.com Web: www.chipsmall.com

Address: A1208, Overseas Decoration Building, #122 Zhenhua RD., Futian, Shenzhen, China



SWITCHCRAFT CABLE CONNECTOR ASSEMBLY INSTRUCTIONS

STEP 1
FEED THE END OF THE CABLE THROUGH THE BOOT AND CABLE CLAMP HOUSING IN THE ORDER AND POSITION SHOWN.

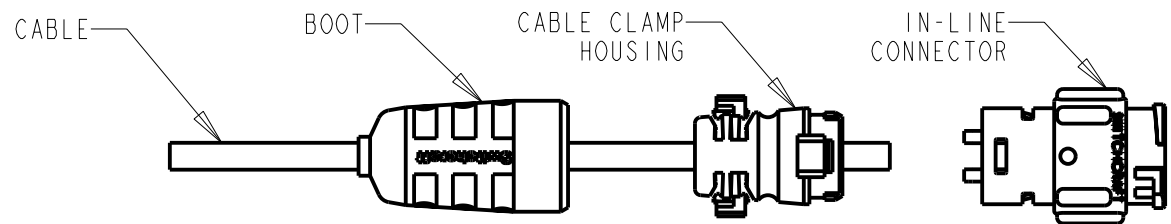

STEP 2
STRIP CABLE AS SHOWN AND BEGIN SOLDERING CONDUCTORS TO PINS. STARTING WITH CONTACT NO. 1 NEXT TO THE "NOTCH" AND FOLLOW WITH THE REMAINING CONDUCTORS CLOCKWISE WITH NO. 6 CONDUCTOR IN THE CENTER.

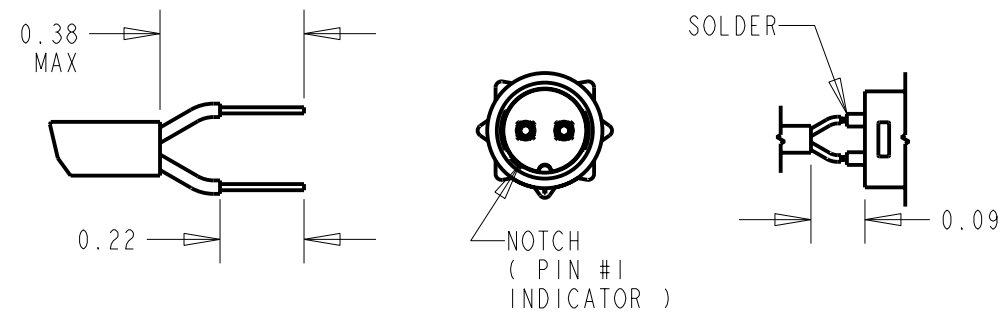

STEP 3
PUSH THE CABLE CLAMP HOUSING FORWARD UNTIL IT LOCKS INTO THE CONNECTOR BODY AND SNAP THE TWO CLAMPS INTO ITS COMPARTMENTS.

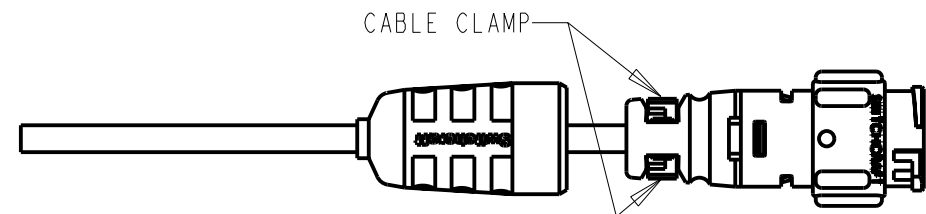

STEP 4
PUSH THE BOOT ALL THE WAY FORWARD TO SEAT TIGHTLY ONTO THE CABLE CLAMP HOUSING.

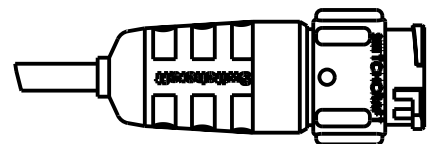

SPECIFICATIONS

MECHANICAL:
SHOCK: MIL-STD 202 METHOD 213B, COND. K.
VIBRATION: MIL-STD 202 METHOD 201
LIFE: 300 INSERTION/WITHDRAWAL CYCLES (MINIMUM)

ELECTRICAL
DIELECTRIC WITHSTANDING VOLTAGE: 1,000 VAC
INSULATION RESISTANCE: 100 MEGOHMS (MIN) AT 77°F
CONTACT RESISTANCE: 5.0 MILLOHMS MAX.
CURRENT RATING: 7.5 AMPS (#20 CONTACT)
13.0 AMPS (#16 CONTACT)

ENVIRONMENTAL
TEMPERATURE LIMITS: -40°C TO +65°C (NON-OPERATING)
MOISTURE RESISTANCE: MIL-STD 202 METHOD 106F
INSULATION RESISTANCE: MIL-STD 202 METHOD 302, COND. B
THERMAL SHOCK: MIL-STD 202 METHOD 107G
SALT SPRAY: MIL-STD 202 METHOD 101D, COND. B
WATER TIGHTNESS TEST: U.S. COAST GUARD CFR 46 PART 110.20

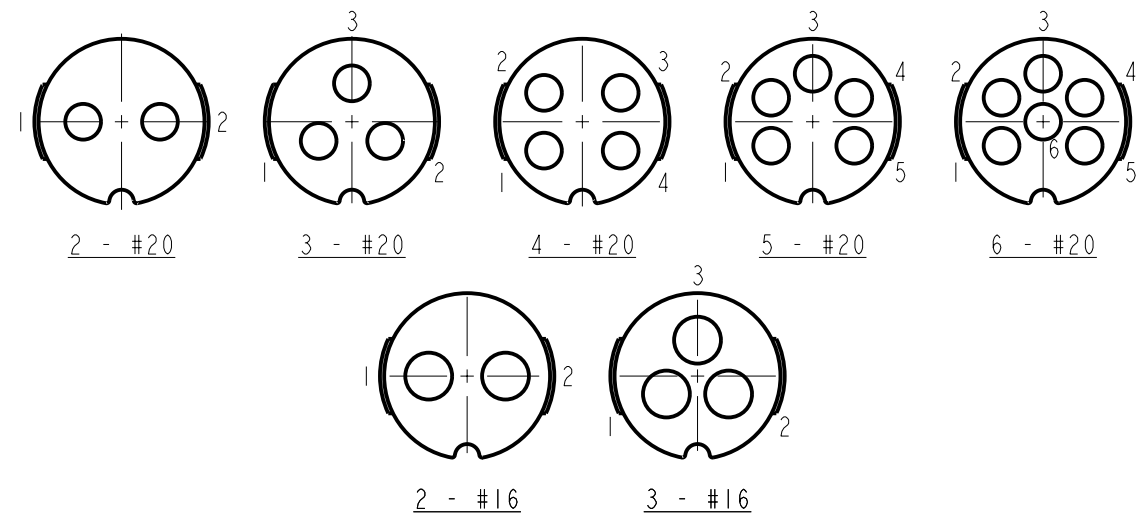

CONTACT ARRANGEMENTS

SHOWN ARE REAR VIEWS OF FEMALE INLINE CONNECTORS

MATERIALS:
IN-LINE CONNECTOR SHELL, CONTACT LOCKING DISK, AND CABLE CLAMP ASSEMBLY: THERMOPLASTIC POLYMER GLASS FIBER, FLAME RETARDANT

REAR BOOT AND CONNECTOR SHELL INTERIOR: THERMOPLASTIC RUBBER

CONTACTS: COPPER BASE ALLOY GOLD-PLATED OVER NICKEL UNDERPLATE

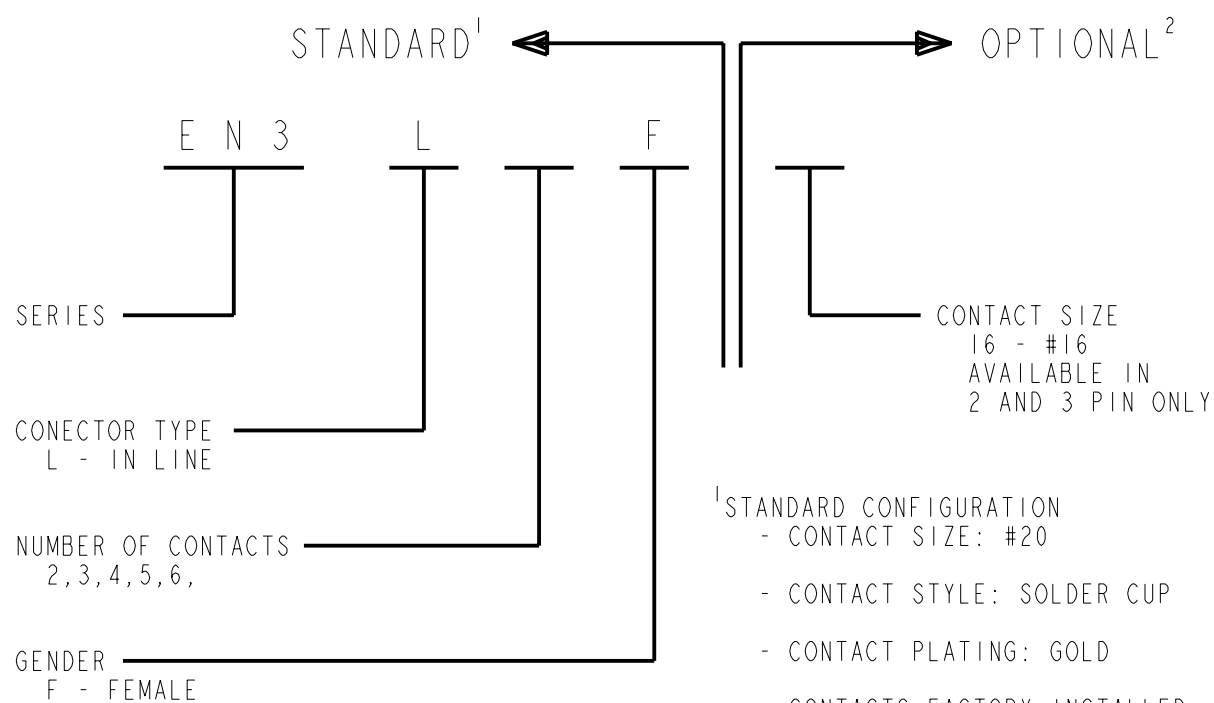

¹STANDARD CONFIGURATION
- CONTACT SIZE: #20
- CONTACT STYLE: SOLDER CUP
- CONTACT PLATING: GOLD
- CONTACTS FACTORY INSTALLED
- PACKAGED IN BULK

²OPTIONAL CONFIGURATION
- LEAVE BLANK FOR STANDARD CONFIGURATION

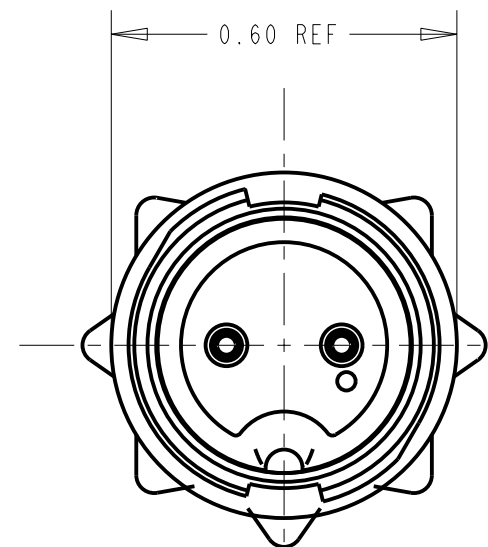
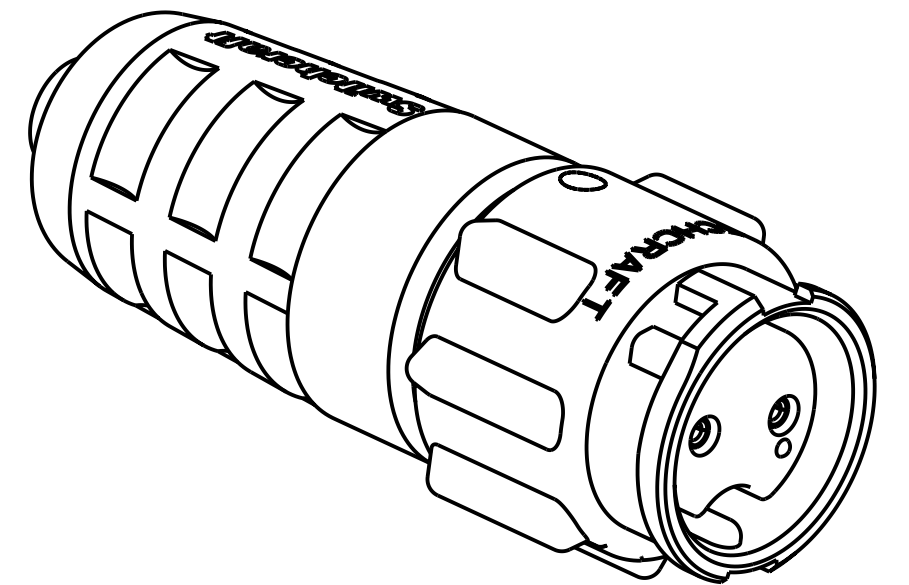
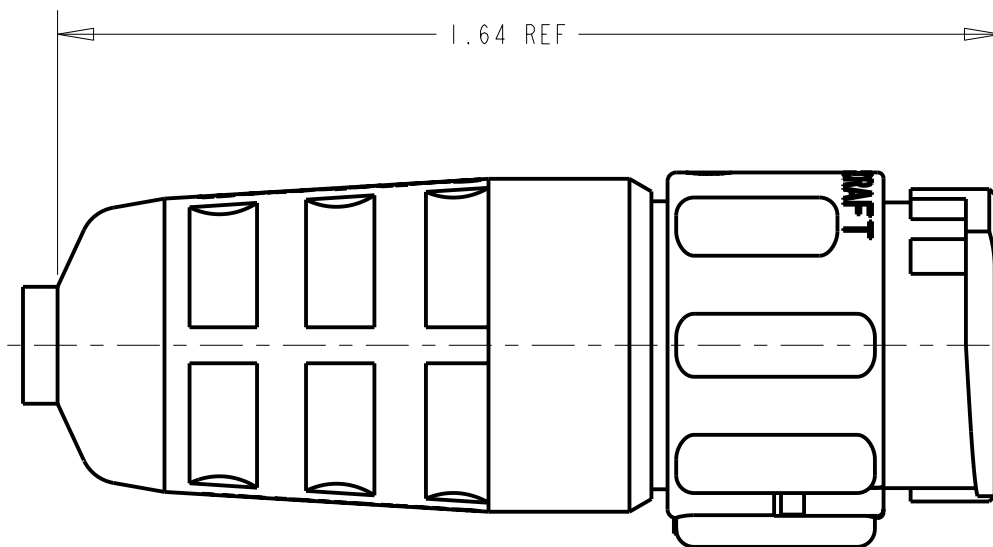
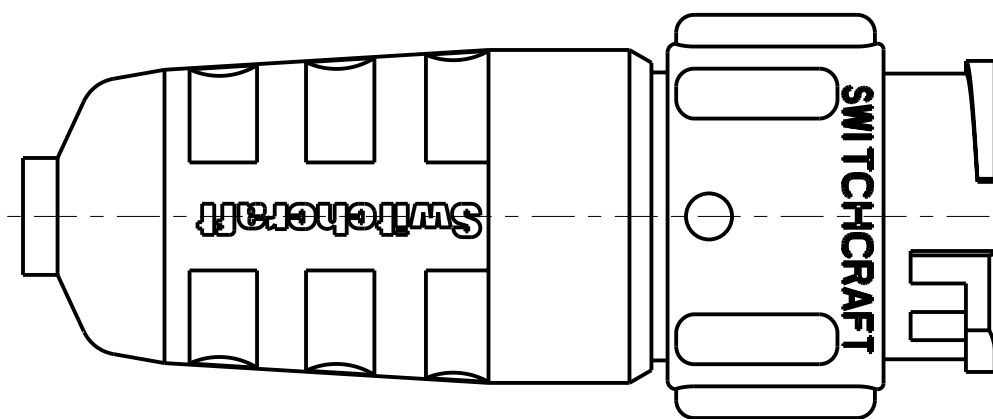

CUSTOMER DRAWING

★ STAR SYMBOL DENOTES CRITICAL DIMENSION					THIS DRAWING DESCRIBES A DESIGN CONSIDERED PROPRIETARY IN NATURE, DEVELOPED AND MANUFACTURED BY SWITCHCRAFT INC. AND IS RELEASED ON A CONFIDENTIAL BASIS FOR IDENTIFICATION PURPOSES ONLY.				
UNLESS OTHERWISE SPECIFIED					SIZE	WIDTH	MULT	LBS/M	TEMPER
1. ALL DIMENSIONS IN INCHES - TWO PLACE DECIMALS ±0.01 - THREE PLACE DECIMALS ±0.005 - ANGLES ±1° - ALL DIA. CONCENTRIC WITHIN 0.005 T.I.R.					FINISH		MATERIAL SPEC No.		
2. FEATURES ON THE SAME CENTERLINE MUST BE ALIGNED WITHIN ±0.002					FIRST USED ON		SCALE 3:1		
3. REMOVE ALL BURRS					DATE DRAWN	BY	CHKD	APVD	Switchcraft®
DO NOT SCALE DRAWING					10-7-96	SG	SG 10-7-96	FL 11-25-96	
REVISIONS					NAME				
REV					FEMALE INLINE CONNECTOR				
ECO NUMBER					PART No.				
DATE					EN3L_F				
BY					REV				
APVD					B				