



Chipsmall Limited consists of a professional team with an average of over 10 year of expertise in the distribution of electronic components. Based in Hongkong, we have already established firm and mutual-benefit business relationships with customers from,Europe,America and south Asia,supplying obsolete and hard-to-find components to meet their specific needs.

With the principle of "Quality Parts,Customers Priority,Honest Operation,and Considerate Service",our business mainly focus on the distribution of electronic components. Line cards we deal with include Microchip,ALPS,ROHM,Xilinx,Pulse,ON,Everlight and Freescale. Main products comprise IC,Modules,Potentiometer,IC Socket,Relay,Connector.Our parts cover such applications as commercial,industrial, and automotives areas.

We are looking forward to setting up business relationship with you and hope to provide you with the best service and solution. Let us make a better world for our industry!



## Contact us

Tel: +86-755-8981 8866 Fax: +86-755-8427 6832

Email & Skype: info@chipsmall.com Web: www.chipsmall.com

Address: A1208, Overseas Decoration Building, #122 Zhenhua RD., Futian, Shenzhen, China



# SPECIFICATIONS

**MECHANICAL:**  
 SHOCK: MIL-STD 202 METHOD 213B, COND. K.  
 VIBRATION: MIL-STD 202 METHOD 201  
 LIFE: 300 INSERTION/WITHDRAWAL CYCLES (MINIMUM)

**ELECTRICAL**  
 DIELECTRIC WITHSTANDING VOLTAGE: 1,000 VAC  
 INSULATION RESISTANCE: 100 MEGOHMS (MIN) AT 77°F  
 CONTACT RESISTANCE: 5.0 MILLOHMS MAX.  
 CURRENT RATING: 7.5 AMPS (#20 CONTACT)  
 6.5 AMPS (7 & 8 PIN #20 CONTACT)  
 13.0 AMPS (#16 CONTACT)

**ENVIRONMENTAL**  
 TEMPERATURE LIMITS: -40°C TO +65°C (NON-OPERATING)  
 MOISTURE RESISTANCE: MIL-STD 202 METHOD 106F  
 INSULATION RESISTANCE: MIL-STD 202 METHOD 302, COND. B  
 THERMAL SHOCK: MIL-STD 202 METHOD 107G  
 SALT SPRAY: MIL-STD 202 METHOD 101D, COND. B  
 WATER TIGHTNESS TEST: U.S. COAST GUARD CFR 46 PART 110.20

**MATERIALS:**  
 PANEL CONNECTOR SHELL, CONTACT LOCKING DISC:  
 THERMOPLASTIC POLYMER GLASS FIBER, FLAME RETARDANT

CONNECTOR SHELL INTERIOR:  
 THERMOPLASTIC RUBBER

CONTACTS: COPPER BASE ALLOY GOLD-PLATED  
 OVER NICKEL UNDERPLATE

HEX NUT: THERMOPLASTIC

**NOTES:**

- HEX NUT TORQUE:  
 8 TO 10 INCH-LBS. OF TORQUE  
 (MUST NOT EXCEED 10 INCH-LBS.)
- HEX NUT SHIPPED UNASSEMBLED.
- CONTACTS SUPPLIED LOOSE.

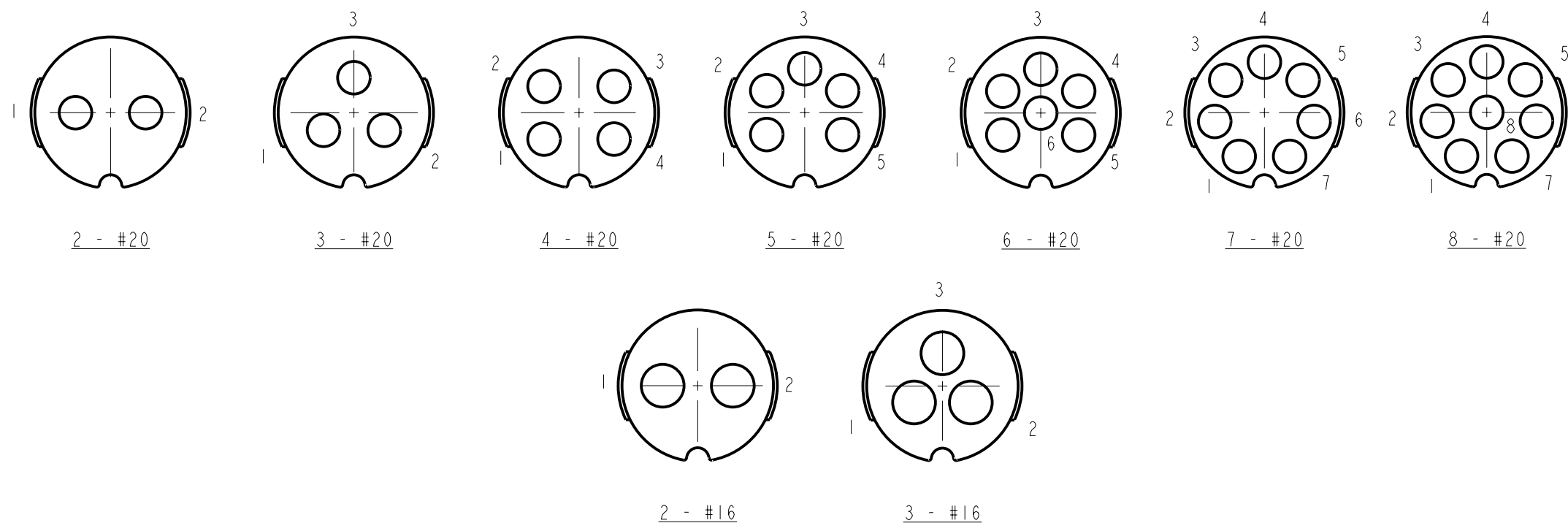

## CONTACT ARRANGEMENT

SHOWN ARE REAR VIEWS OF MALE PANEL CONNECTORS

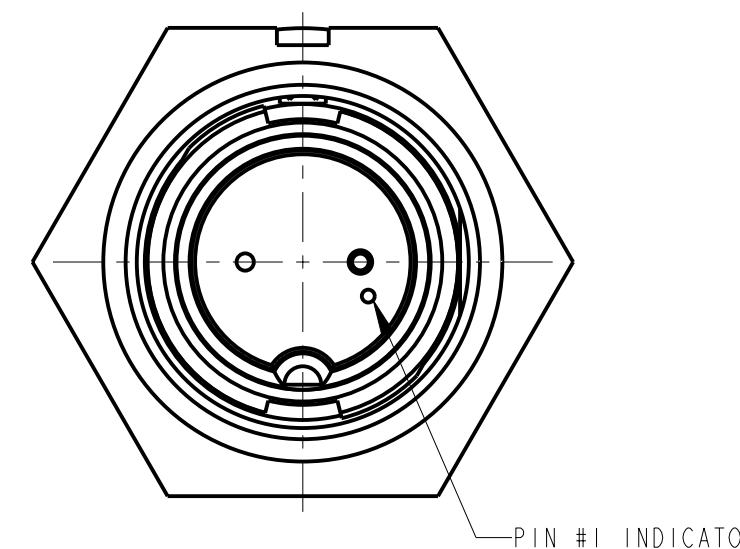
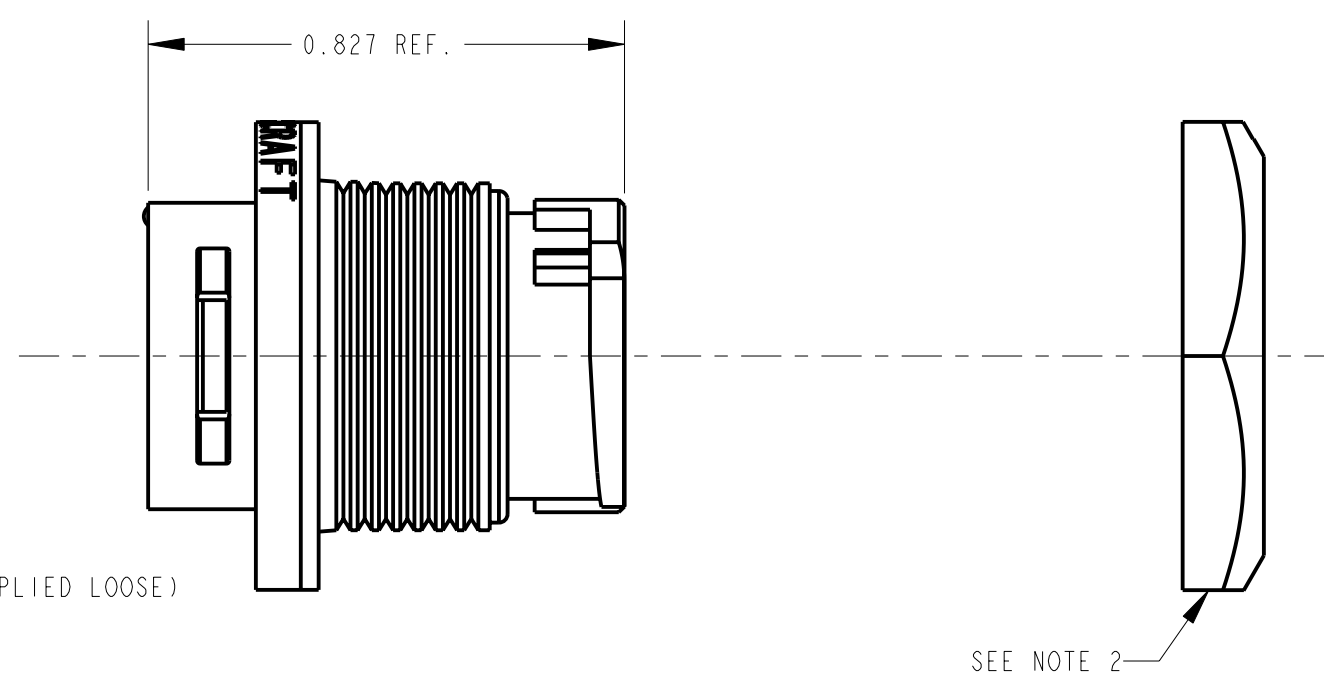
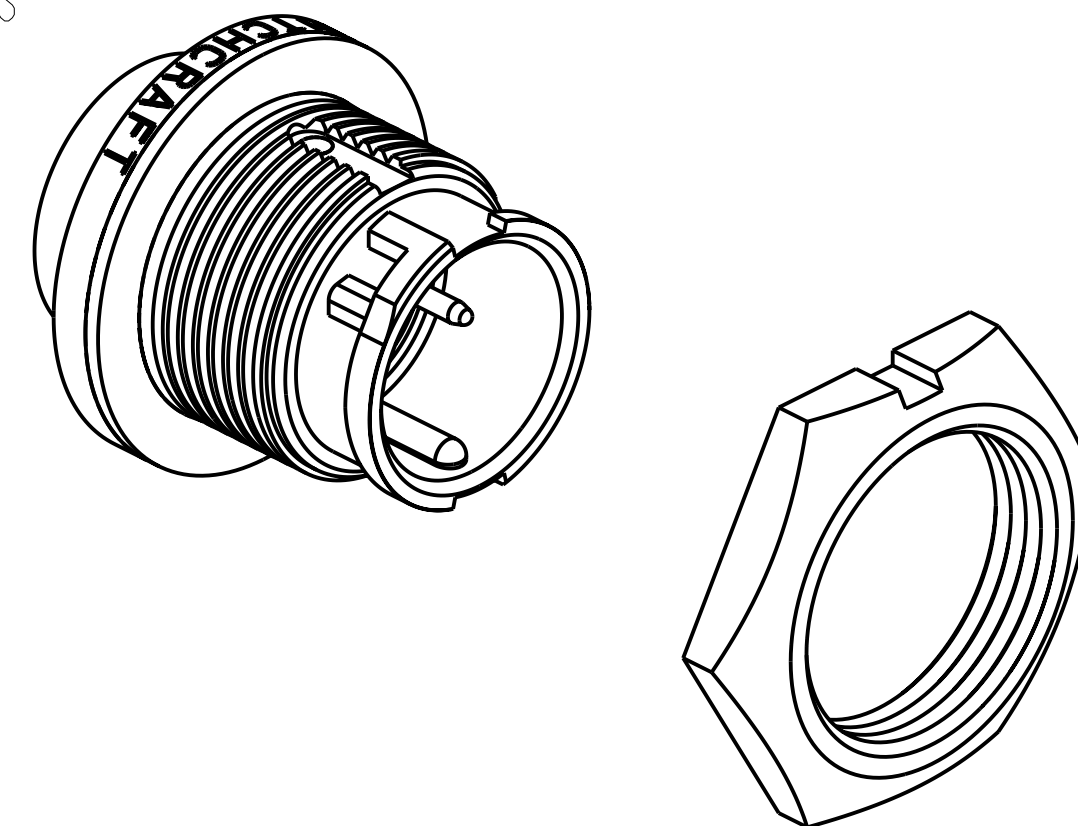
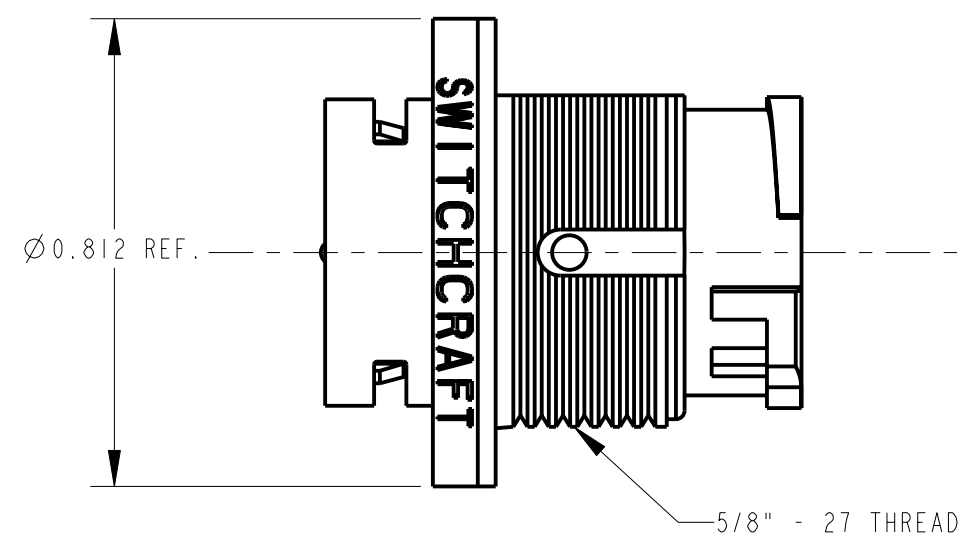

CUSTOMER DRAWING

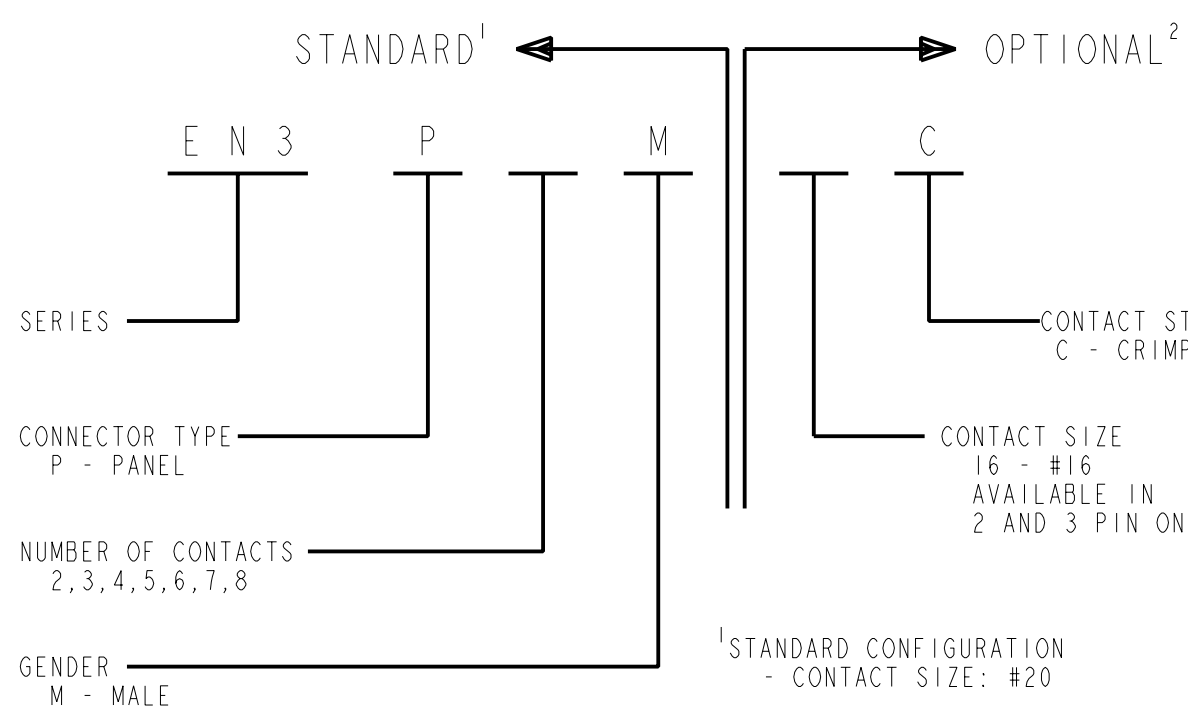

- <sup>1</sup>STANDARD CONFIGURATION  
 - CONTACT SIZE: #20  
 - CONTACT STYLE: SOLDER CUP  
 - CONTACT PLATING: GOLD  
 - PACKAGED IN BULK
- <sup>2</sup>OPTIONAL CONFIGURATION  
 - LEAVE BLANK FOR STANDARD CONFIGURATION

★ STAR SYMBOL DENOTES CRITICAL DIMENSION				THIS DRAWING DESCRIBES A DESIGN CONSIDERED PROPRIETARY IN NATURE, DEVELOPED AND MANUFACTURED BY SWITCHCRAFT INC. AND IS RELEASED ON A CONFIDENTIAL BASIS FOR IDENTIFICATION PURPOSES ONLY.				
UNLESS OTHERWISE SPECIFIED				SIZE	WIDTH	MULT	LBS/M	TEMPER
E	24661	3-4-04	JL EB	FINISH		MATERIAL SPEC No.		
D	23595	2-6-01	JL DK	SPEC No.		SCALE 3:1		
C	22232	4-29-98	SG RB	FIRST USED ON		DATE DRAWN BY CHKD APVD		
B	ECO #21461	11-11-96	MM FL	11-22-95 SG 11-22-95		12-1-95 RB		
A	RELEASE TO MFG ECO #20698	4-4-96	CCB RB	NAME		PART No.		
REV	ECO NUMBER	DATE	BY	APVD	MALE PANEL CONNECTOR		EN3P_M_C	
REVISIONS				DO NOT SCALE DRAWING				REV E



SHEET 1 OF 2

SWITCHCRAFT PANEL CONNECTOR ASSEMBLY INSTRUCTIONS

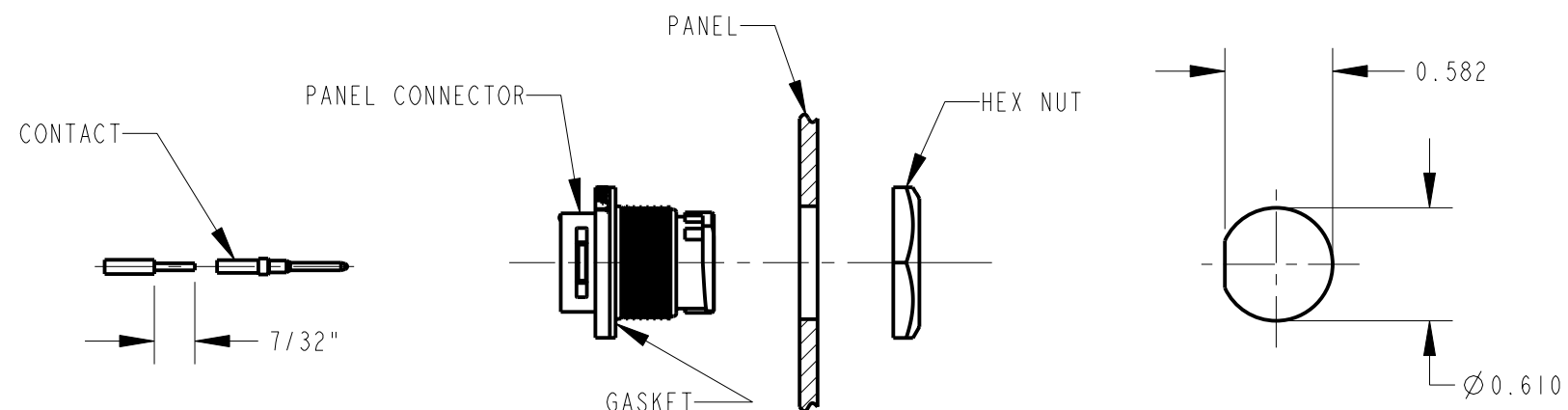

NOTE: STRIP CABLE AS SHOWN AND CRIMP WIRE TO CONTACT BEFORE INSERTING TO CONNECTOR

RECOMMENDED PANEL CUT-OUT

EN3 CRIMP TOOL

SWITCHCRAFT PART NUMBER	DESCRIPTION	CONTACT SIZE	MANUFACTURER PART NUMBER	MILITARY PART NUMBER
EN3CR	CRIMP HAND TOOL FRAME	#20, #16	DMC MH860	M22520/7-01
EN3CRAUTO	POWER CRIMP TOOL	#20, #16	DMC WA22P	
EN3POS20	POSITIONER	#20	DMC 86-15	M22520/7-02
EN3POS16	POSITIONER	#16	DMC 86-3	M22520/7-04

CONTACT PART NO.	CONTACT SIZE	DIM. "A"	DIM. "B"	DIM. "C"	DIM. "D"	WIRE GAUGE RANGE	INSERTION/EXTRACTION HAND TOOL
EN3CC20M	#20	0.209	0.047	0.069	0.041	#20-22-24	EN3INS20
EN3CC16M	#16	0.218	0.067	0.095	0.062	#16-18-20	EN3IN16

RECOMMENDED STRIP LENGTH: 0.218

ALL DIMENSIONS ARE REFERENCE UNLESS OTHERWISE SPECIFIED

CONTACT INSERTION INSTRUCTIONS

HOUSING NOT SHOWN

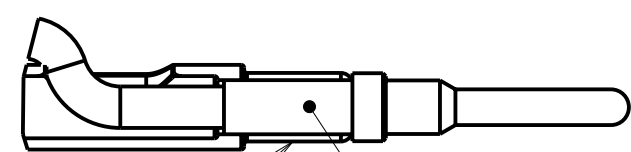

HAND TOOL CONTACT

PLACE CRIMP CONTACT AND CONDUCTOR ONTO HAND TOOL.

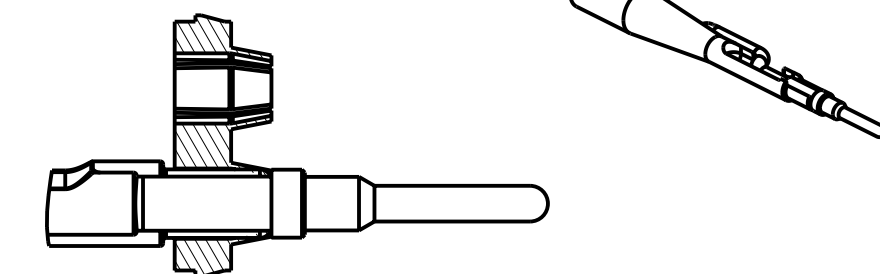

INSERT TOOL INTO HOUSING UNTIL IT BOTTOMS ONTO DISC.

CONTACT EXTRACTION INSTRUCTIONS

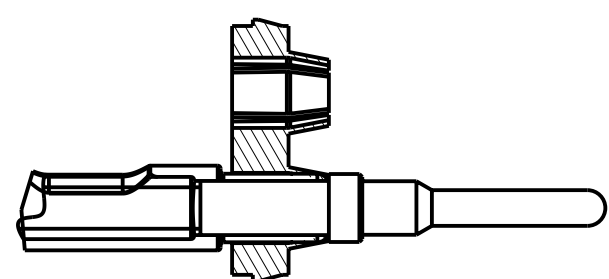

INSERT TOOL INTO HOUSING UNTIL IT BOTTOMS ONTO DISC.

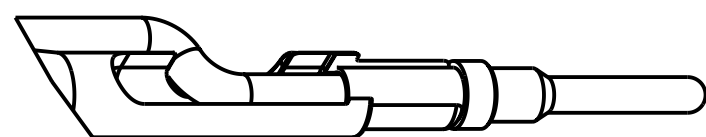

PLACE CONDUCTOR INTO SLOT ON HAND TOOL AS SHOWN.

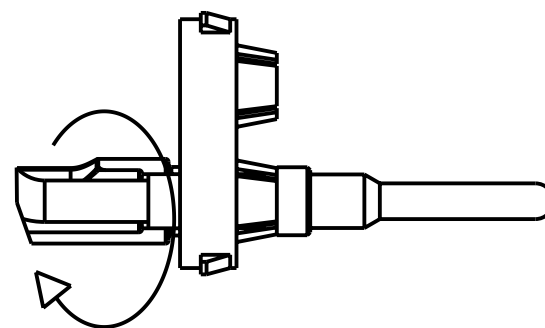

ROTATE HAND TOOL CLOCKWISE AND REMOVE FROM HOUSING.

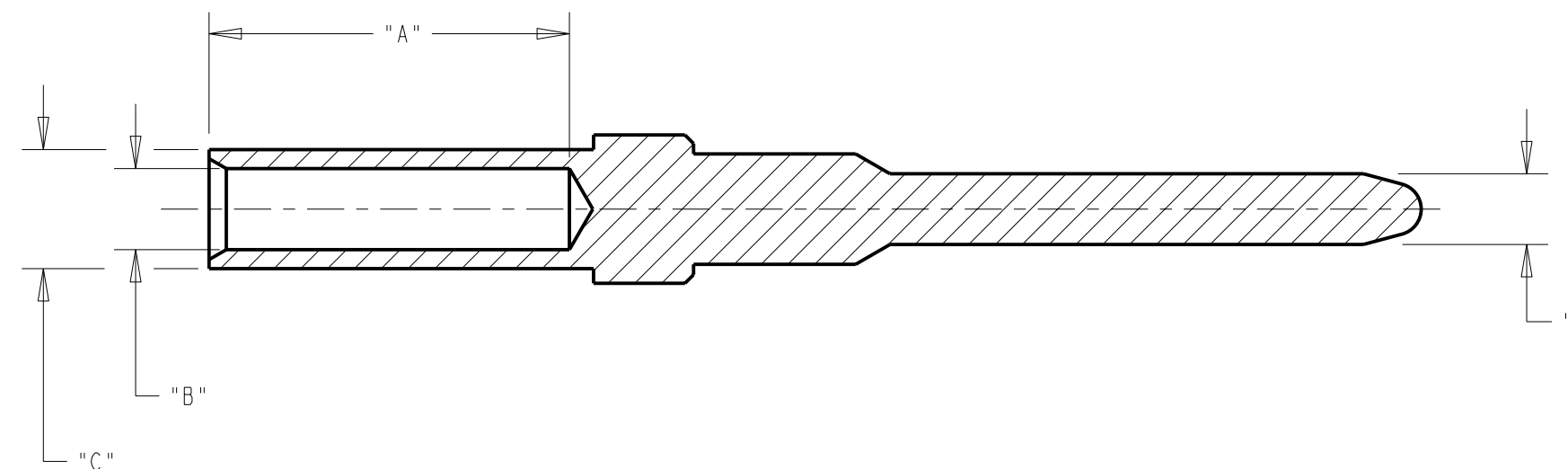

CUSTOMER DRAWING

SCALE 3:1	<b>Switchcraft®</b>	
DATE DRAWN 15-Apr-96		
DRAWN BY CCB	PART No. EN3P_M_C	REV E