



Chipsmall Limited consists of a professional team with an average of over 10 year of expertise in the distribution of electronic components. Based in Hongkong, we have already established firm and mutual-benefit business relationships with customers from,Europe,America and south Asia,supplying obsolete and hard-to-find components to meet their specific needs.

With the principle of "Quality Parts,Customers Priority,Honest Operation,and Considerate Service",our business mainly focus on the distribution of electronic components. Line cards we deal with include Microchip,ALPS,ROHM,Xilinx,Pulse,ON,Everlight and Freescale. Main products comprise IC,Modules,Potentiometer,IC Socket,Relay,Connector.Our parts cover such applications as commercial,industrial, and automotives areas.

We are looking forward to setting up business relationship with you and hope to provide you with the best service and solution. Let us make a better world for our industry!



Contact us

Tel: +86-755-8981 8866 Fax: +86-755-8427 6832

Email & Skype: info@chipsmall.com Web: www.chipsmall.com

Address: A1208, Overseas Decoration Building, #122 Zhenhua RD., Futian, Shenzhen, China



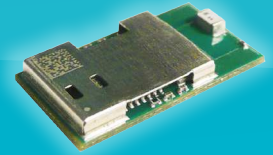

New PAN1322 Series Place and Play *Bluetooth*® Module



All-In-One, Place and Play *Bluetooth* Module

Introducing **Panasonic's** next generation, smartphone compatible, place and play *Bluetooth* module, the **PAN1322 Series**. This module features an embedded microcontroller, *Bluetooth* 2.1 + EDR stack, serial port profile (SPP), AT command set API and antenna. This cost engineered solution is based on a single chip solution that integrates an ARM7TDMI processor with a *Bluetooth* controller. The BT 2.1 + EDR stack provides secure, reliable, high speed data connections using Secure Simple Pairing (SSP) eliminating manual password creation. Embedded serial port profile (SPP) frees application resources while the AT command set API creates a simple firmware interface using modem commands. An onboard antenna does away with 2.4GHz RF circuit complexity.

Created with the design engineer in mind, product design cycles are greatly reduced using **Panasonic's** reference design and design review services. PCB layouts are simplified using available Gerber files and minimized with Panasonic's tiny footprint technology. The module is and is just 15.6mm x 8.7mm x 2.8mm and fully shielded to improve immunity. GPIO is exposed using AT commands. All Panasonic *Bluetooth* RF modules carry FCC, IC, CE *Bluetooth* certifications.

The **PAN1322 Series** recognizes Apple's authentication coprocessor and supports *Bluetooth* Serial Port Profile (SPP) data communication¹ with Apple's iPhone and iPad®*. Connectivity also includes Android, smart phones and all *Bluetooth* enabled devices².

Panasonic remains committed to customers as a module manufacturer by extending product life using legacy footprints and firmware interfaces to make the **PAN1322 Series** fully compatible with the module it replaces, the **PAN1321 Series**.

Hardware and firmware prototyping and testing are accelerated using the **EVAL_PAN1322** development kit and SPP Toolbox development environment.

1. Apple authentication coprocessor and MFI certification is required.

2. Connectivity requires that devices support *Bluetooth* Serial Port Profile

*Apple iPad and iPhone are trademarks of Apple Inc

Features

- *Bluetooth* Version 2.1 + EDR
- SPP Device A and B, RFCOMM Profiles
- Industrial Temperature Range, -40 to +85°C
- No External Components Needed
- Onboard Voltage Regulator, V_{IN} = 2.7 to 3.6 V
- Integrated ARM7RDMI 32-Bit Processor w/Patchable EEPROM
- 3.25 MBaud UART
- GPIO w/Interrupt and Wake-Up Capabilities

Applications

- iOS and Android Devices
- Wireless Sensors
- Cable Replacement
- Industrial
- Medical
- Automotive

Block Diagram (PAN1322-SPP)

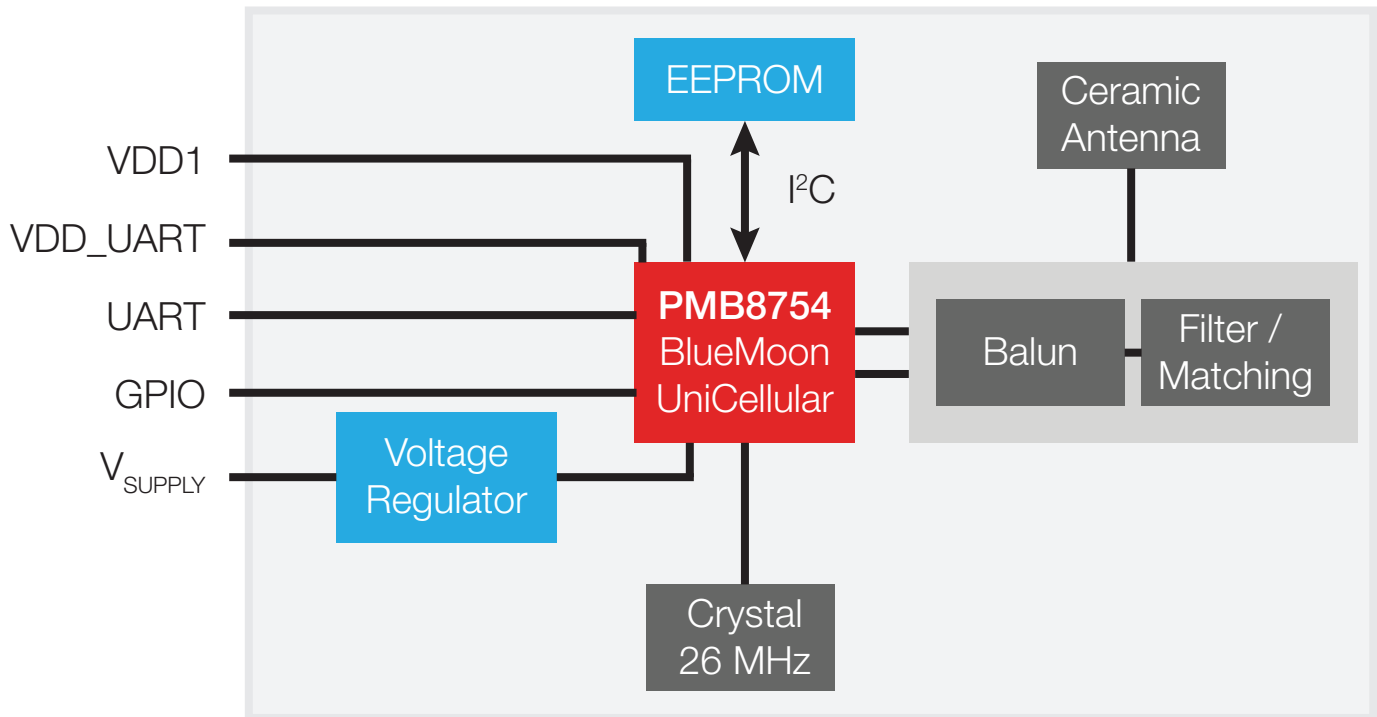

Technical Characteristics

Parameter	Value	Condition
Receiver Sensitivity	-86 dBm typ.	Ideal Signal
Output Power	+3 dBm typ.	@ 50 Ohm Antenna Pin
Power Supply	2.7 to 3.5 V	Single Voltage Operation
Ultra Low Power Mode	80 μ A	T = 2.5°C
ACL (Transmit 3-DH1)	40 mA	Enhanced Data Rate, 531.2kb/s
ACL (Receive 3-DH1)	37 mA	Enhanced Data Rate, 531.2kb/s
Operating Temperature	-40 to +85°C	

Ordering Information

Part Number	Description
ENW-89841A3KF	PAN1322 Bluetooth Module, SPP, Integrated Antenna
EVAL_PAN1322	PAN1322 Evaluation Kit

Additional Information

For detailed specification information on the **PAN1322** Place and Play Bluetooth Module, visit our website at:

<http://www.panasonic.com/rfmodules/>