

Chipsmall Limited consists of a professional team with an average of over 10 year of expertise in the distribution of electronic components. Based in Hongkong, we have already established firm and mutual-benefit business relationships with customers from,Europe,America and south Asia,supplying obsolete and hard-to-find components to meet their specific needs.

With the principle of “Quality Parts,Customers Priority,Honest Operation,and Considerate Service”,our business mainly focus on the distribution of electronic components. Line cards we deal with include Microchip,ALPS,ROHM,Xilinx,Pulse,ON,Everlight and Freescale. Main products comprise IC,Modules,Potentiometer,IC Socket,Relay,Connector.Our parts cover such applications as commercial,industrial, and automotives areas.

We are looking forward to setting up business relationship with you and hope to provide you with the best service and solution. Let us make a better world for our industry!



Contact us

Tel: +86-755-8981 8866 Fax: +86-755-8427 6832

Email & Skype: info@chipsmall.com Web: www.chipsmall.com

Address: A1208, Overseas Decoration Building, #122 Zhenhua RD., Futian, Shenzhen, China

Bluetooth Low Energy PAN1740 Beacon

Panasonic

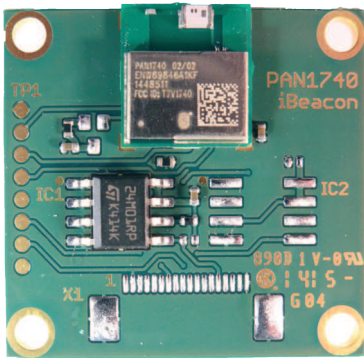

OUTLINES

A Beacon device will transmit its own unique identification number to the local area. Software on a receiving device such as a smartphone app will receive this data and can perform various functions, e.g. present the user with additional information on points of interest or special promotions in a shop. Received beacon transmissions can also be used for ranging or indoor positioning applications in various products.

Using the PAN1740 Beacon will allow the customer to easily realise Beacon applications with limited development efforts. The proven design of the Bluetooth module PAN1740 guarantees quality as well as reliability. Very low power consumption of less than 5mA in Tx mode allow products to run on coin cell batteries for multiple years.

The onboard flash memory can be used for customer applications. The battery holder fits standard CR2032 coin cell batteries. Reference designs for plastic housing as well as software example code is available.

FEATURES

- Based on single-mode BT Smart System-on-Chip PAN1740
- ARM CORTEX M0 with internal 32kB OTP, additional memory
- Small size (26x24mm) with antenna
- Based on FCC/IC/CE certified PAN1740
- Battery holder for CR2032 coin cell
- Reference design for standard housing available
- Approximate battery life 18 months, 700ms advertising interval
- Software SDK / Application Notes available

MODULES
Panasonic Electronic Devices Europe GmbH
WIRELESS

Design and Specifications are subject to change without notice. Ask the factory for technical specifications before purchase and/or use. If there is any doubt regarding the safety of this product, kindly inform us immediately for technical consultation.
The Bluetooth word mark and logos are owned by the Bluetooth SIG, Inc.

PAN1740 Beacon Rev. 0.1

Hardware Status:
Samples

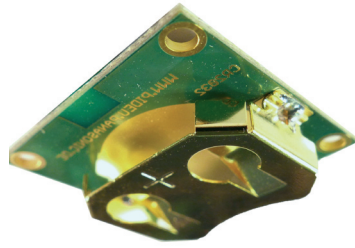
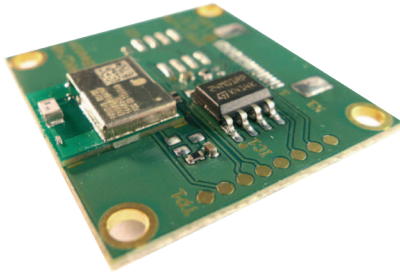

APPLICATIONS

- Bluetooth Low Energy Tags
- Indoor Positioning
- Advertising in Retail Environment
- Find me Applications
- Product Information via Bluetooth Smart
- Point of Interest
- Mobile Payment

PART NUMBER

Product	Part Number
PAN1740 Module	ENW89846A1KF
PAN1740 Beacon	ENW89849A1KF
PAN1740 Beacon Evaluation Kit	ENW89849AYKF

BLOCK DIAGRAM

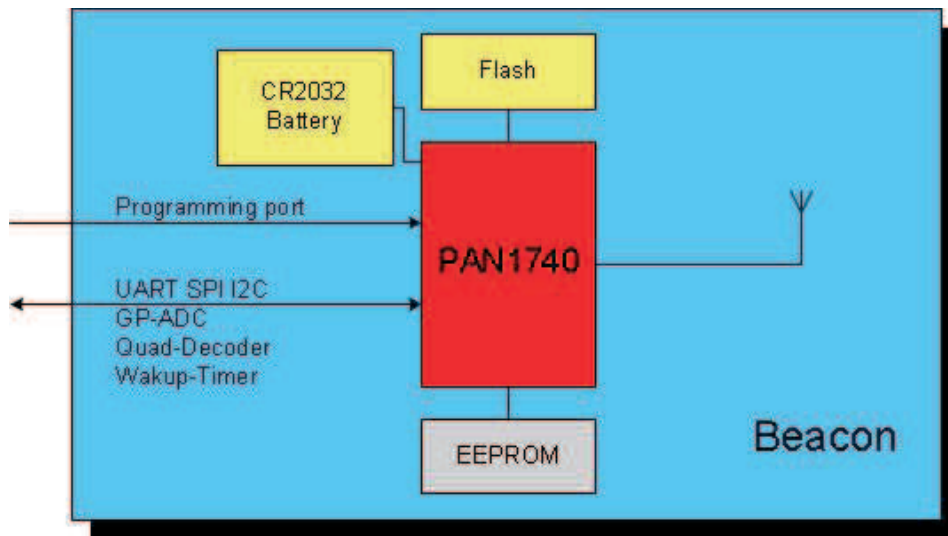

TECHNICAL CHARACTERISTICS

Parameter	Value	Condition / Note
Receiver Sensitivity	- 93 dBm	1% PER
Output Power	0 dBm	Maximum setting
Power Supply	2.35 to 3.3 V	Single operation voltage
Transmit Mode	4.9 mA	GFSK
Receive Mode	4.9 mA	GFSK
Operating Temperature Range	-40C / +85C	Industrial Range
Size	26x24 mm	