



Chipsmall Limited consists of a professional team with an average of over 10 year of expertise in the distribution of electronic components. Based in Hongkong, we have already established firm and mutual-benefit business relationships with customers from,Europe,America and south Asia,supplying obsolete and hard-to-find components to meet their specific needs.

With the principle of “Quality Parts,Customers Priority,Honest Operation,and Considerate Service”,our business mainly focus on the distribution of electronic components. Line cards we deal with include Microchip,ALPS,ROHM,Xilinx,Pulse,ON,Everlight and Freescale. Main products comprise IC,Modules,Potentiometer,IC Socket,Relay,Connector.Our parts cover such applications as commercial,industrial, and automotives areas.

We are looking forward to setting up business relationship with you and hope to provide you with the best service and solution. Let us make a better world for our industry!



Contact us

Tel: +86-755-8981 8866 Fax: +86-755-8427 6832

Email & Skype: info@chipsmall.com Web: www.chipsmall.com

Address: A1208, Overseas Decoration Building, #122 Zhenhua RD., Futian, Shenzhen, China



Bluetooth Low Energy Single Mode 4.0 System on chip Module PAN1740



OUTLINES



PAN1740 is the next generation Bluetooth Low Energy Module from Panasonic with reduced form factor, significantly lower power consumption and embedded Software Stack. The Single-mode Bluetooth Smart System-on-Chip module is optimized for low power, small size and low system cost products. It reduces external component count, development effort and time to market.

The Module is manufactured in a very small 9.0* 9.5* 1.8 mm³ SMD package with shielded case and chip antenna. The power consumption of only 4.9mA in Tx and Rx mode makes the use of coin cell batteries possible or reduces the needed battery capacity and cost of existing solution by at least 50%. It is qualified according to Bluetooth 4.0 standard. FCC, IC and CE approvals are under preparation.

The PAN1740 comes with a complete software development platform, which includes a qualified Bluetooth Smart single-mode stack on chip. Multiple Bluetooth Smart profiles for consumer wellness, sport, fitness, security and proximity applications are supplied as standard, while additional customer profiles can be developed and added as needed.

FEATURES

General

- Single-mode Bluetooth Smart System-on-Chip
- ARM CORTEX M0 CPU
- Small 9.0 x 9.5 x 1.8 mm SMD package with antenna
- Includes 16MHz and 32.768kHz crystal
- Temperature Range from -40°C to +85°C
- Power consumption 4.9mA Rx and Tx
- Link budget 93dBm (Rx Sensitivity -93, Tx 0 dBm)

Interfaces

- GPIO, UART, SPI, I²C, 3-axis QD, ADC

MODULES
WIRELESS
 Panasonic Electronic Devices Europe GmbH

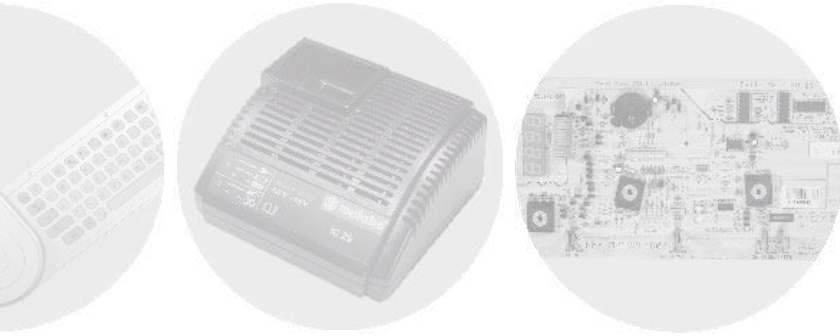

APPLICATIONS

- Wearable Devices
- Health Care, Medical Diagnostic Systems
- Sports and Leisure Equipment
- Mobile phone accessories
- Industrial Measurement and Diagnosis
- Devices with critical Power Consumption

BLOCK DIAGRAM

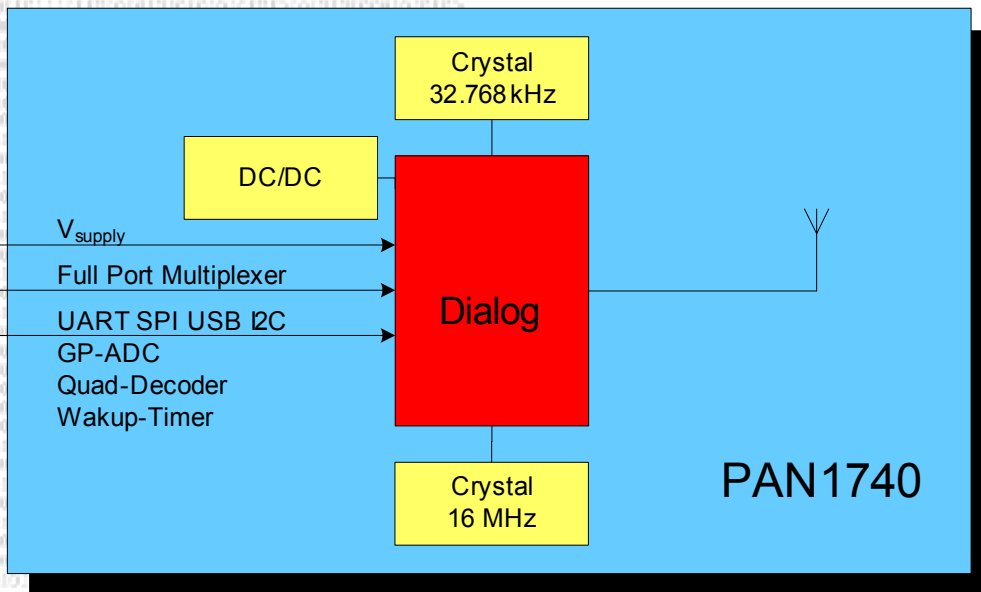

Memory

- 42k SRAM
- 32k OTP Memory for Profiles and Apps (delivered blank)
- 84k ROM for LE Host and Boot ROM

OTP (One Time Programmable).
The PAN1740 is programmed on the customer's production line. Optional pre-programming available for higher volume. Apps and Profiles are copied from OTP, during start up, and executed in SRAM.

TECHNICAL CHARACTERISTICS

Parameter	0,1% BER	Value	Condition / Note
Receiver Sensitivity (1% PER)		- 93 dBm	BER 1%
Output Power		0 dBm	Maximum setting
Power Supply		2.35 to 3.3 V	Single operation voltage
Transmit Mode		4.9 mA	GFSK
Receive Mode		4.9 mA	GFSK
Operating Temperature Range		-40C / +85C	Industrial Range