



Chipsmall Limited consists of a professional team with an average of over 10 year of expertise in the distribution of electronic components. Based in Hongkong, we have already established firm and mutual-benefit business relationships with customers from,Europe,America and south Asia,supplying obsolete and hard-to-find components to meet their specific needs.

With the principle of “Quality Parts,Customers Priority,Honest Operation,and Considerate Service”,our business mainly focus on the distribution of electronic components. Line cards we deal with include Microchip,ALPS,ROHM,Xilinx,Pulse,ON,Everlight and Freescale. Main products comprise IC,Modules,Potentiometer,IC Socket,Relay,Connector.Our parts cover such applications as commercial,industrial, and automotives areas.

We are looking forward to setting up business relationship with you and hope to provide you with the best service and solution. Let us make a better world for our industry!



Contact us

Tel: +86-755-8981 8866 Fax: +86-755-8427 6832

Email & Skype: info@chipsmall.com Web: www.chipsmall.com

Address: A1208, Overseas Decoration Building, #122 Zhenhua RD., Futian, Shenzhen, China



HYDRA-X10

Power Application Controllers™

PAC5210 - HYDRA-X User's Guide



www.active-semi.com

CONTENTS

Contents	2
Overview	3
HYDRA-X10 Body Resources.....	5
Header Descriptions	5
HYDRA-X10 Pinout and Signal Connectivity	5
Power Input	6
Operating the HYDRA-X10 Body With 12V VIN.....	6
LED's	7
SWD Debugging.....	8
SWD Jumper/Shunt and Push Button	8
Serial Communications.....	9
HYDRA-X10 Setup.....	11
HYDRA-X Heads.....	12
HYDRA-X Prototype Heads.....	12
HYDRA-X Head Design.....	14
About Active-Semi.....	15

OVERVIEW

Active-Semi's HYDRA-X10 development platform is a complete hardware solution enabling users not only to evaluate the PAC5210 device, but also develop power applications revolving around this powerful and versatile Cortex M0 based microcontroller. The module contains a PAC5210 power application microcontroller and all the necessary circuitry to properly energize the MCU and its internal peripherals once power is applied.

To aid in the application development The HYDRA-X10 offers access to each and every one of the PAC5210 device's signals by means of a series of female header connectors. Whereas the HYDRA-X10 module is referred to as the HYDRA-X Body, subsequent daughter card modules can be interfaced through these female connectors by merging both boards together. Throughout the rest of this documentation, said attachable daughter cards will be referred to as Heads.

The HYDRA-X10 Body also contains all the necessary circuitry to connect the module to a PC computer through a conventional USB port which can then be used in the communication efforts by taking advantage of the PAC5210's UART interface. Graphical User Interface (GUI) software suites can then be used to externally control particular application's features.

The final block within the HYDRA-X10 Body is a complete Serial Wire Debug (SWD) module which allows the microcontroller to be both programmed and debugged in real time. This SWD debugger block follows the CoLinkEx architecture and is compatible with the CooCox Integrated Development Environment (IDE).

Both the USB to UART and SWD debugger can be disconnected from the PAC5210 device in case the user wishes to utilize a different means of serial communications or SWD debugging.

Active-Semi's HYDRA-X10 Body kit consists of the following:

- HYDRA-X10 Body module
- HYDRA-X10 User's Guide
- Schematics, BOM and Layout Drawings

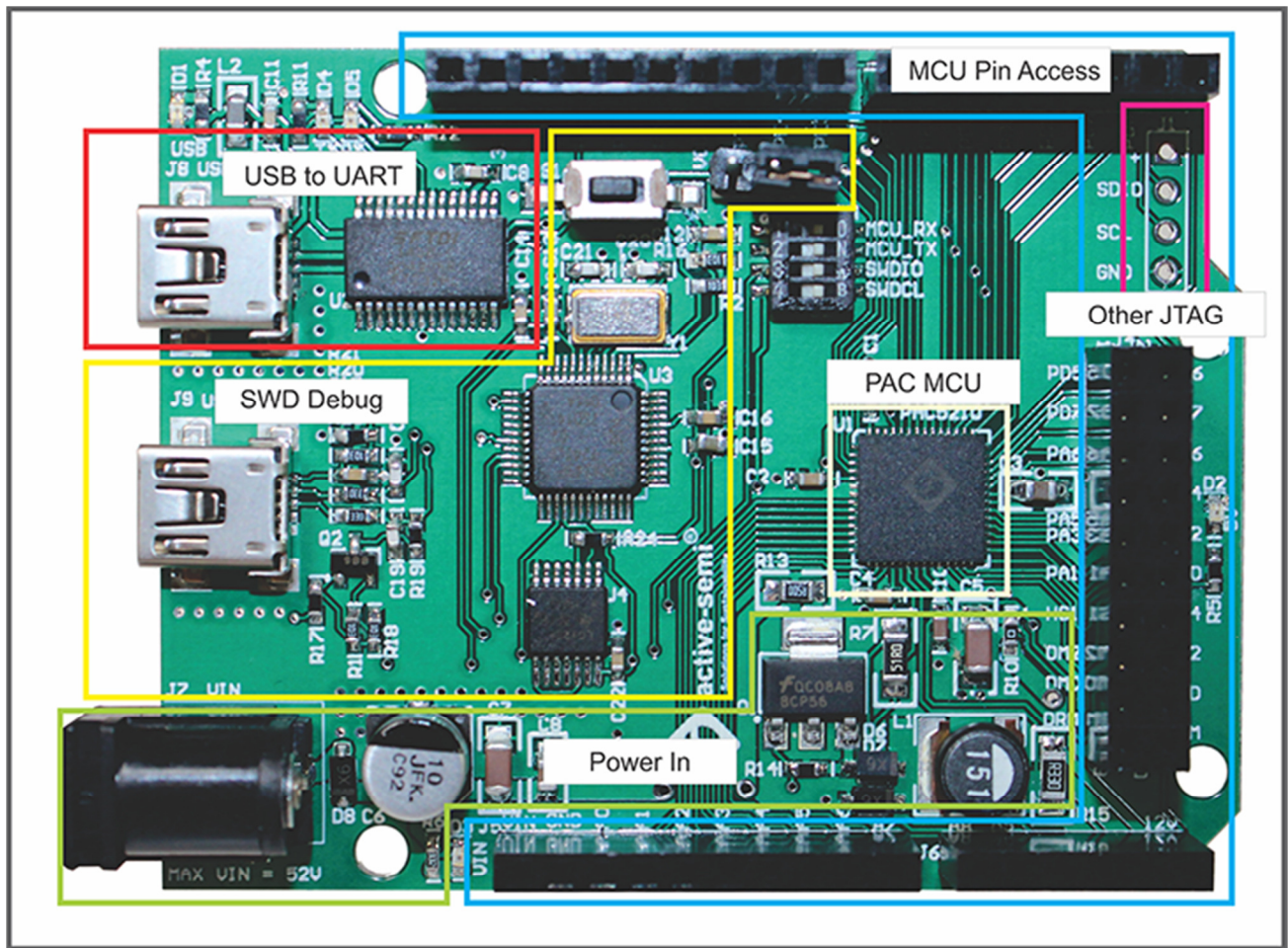

Figure 1: HYDRA-X10 Body Block Diagram

Solution Benefits:

- Ideal for general purpose power applications and controllers
- Single-IC PAC5210 with 14 PWM outputs, 14 ADC inputs, I2C, UART, SPI and GPIO.
- USB 2 UART communication blocks allows communications with a PC computer
- Integrated SED debugger allows both programming and in real time debugging
- Foot print compatible with Arduino platform offerings
- Schematics, BOM, Layout drawings available

The following sections provide information about the hardware features of Active-Semi's HYDRA-X10 turnkey solution.

HYDRA-X10 BODY RESOURCES

Header Descriptions

The following table shows the female header descriptions for the HYDRA-X10 Body module.

Header	Pin	Description
J1	1	PAC5210 secondary SWD port power (5V).
	2	PAC5210 secondary SWD port data input/output.
	3	PAC5210 secondary SWD port clock.
	4	PAC5210 secondary SWD port ground (GND).
J2	1-10	Refer to HYDRA-X10 pinout diagram
J3	1-8	Refer to HYDRA-X10 pinout diagram
J4	1-20	Refer to HYDRA-X10 pinout diagram
J5	1-6	Refer to HYDRA-X10 pinout diagram
J6	1-10	Refer to HYDRA-X10 pinout diagram
J7	-	VIN Power Input barrel connector (16V to 52V)
J8	-	USB to UART USB connector.
J9	-	USB to SWD debugger connector.

HYDRA-X10 Pinout and Signal Connectivity

The following diagram shows the female header pinout for the HYDRA-X10 Body module, as seen from above:

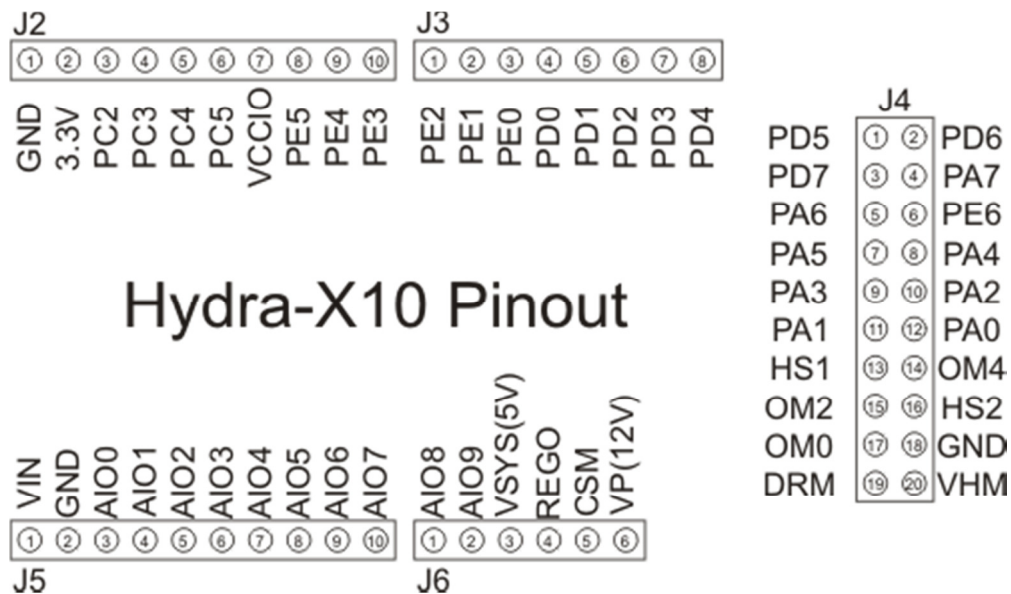

Figure 2 HYDRA-X10 Pinout

Power Input

Power to the Hydra-X10 Body module can be applied to the J7 barrel connector or to the J5 female header connector's VIN and GND terminals. Power to the module should not exceed 52V.

The barrel connector power input is protected against voltage reversal. However, the VIN input at the J5 connector is not. Heads interfacing to the HYDRA-X10 should observe correct voltage polarity.

Barrel Connector J7 correct polarity is with the center pin connected to VIN and the shell connected to GND.



Figure 3 Barrel Connector J7 Polarity

The HYDRA-X10 is optimized to operate with voltages ranging from 16V to 52V. When the VIN input voltage goes above 16V, the system exits UVLO protection and all subsystems, including voltage regulators, analog front end and microcontroller, are enabled. When an operational voltage is applied, LED D2 will light up. This is the LED which notifies VSYS (5V) rail is up and running. 3.3V and 1.8V regulators will also be operating at this point in time. Module is ready for use.

Operating the HYDRA-X10 Body With 12V VIN

Although the PAC5210 device is optimized to operate at higher than 12V voltages, it is still possible to operate the module with voltages in between 12V and 16V. Care must be taken, however, not to exceed the 16V mark.

In order to operate the module at these lower voltages, the user must apply a short between the VHM and VP terminals. This tells the system not to use the Buck regulator. The 12V applied by the user at the VIN terminal, is then used to generate 5V, 3.3V and 1.8V.

LED's

The HYDRA-X10 module incorporates a small number of LEDs for diagnostic purposes. These LED functions cannot be controlled by the user application. If the user requires the usage of LEDs, these can be added to the available GPIO resources.

The following table shows the available LEDs and their associated diagnostic function.

LED	Description
D1	USB Voltage. Lights up when an USB link is present at the J8 connection. Driven by the USB's 5V
D2	VSYS (5V). Light up when the PAC5210 device is successfully powered up by VIN.
D3	VIN. Lights up as VIN voltage is applied.
D4	USB to UART TX. Lights up with data transmission to the microcontroller
D5	USB to UART RX. Lights up with data transmission from the microcontroller.

SWD Debugging

The HYDRA-X10 module comes equipped with a fully operational and ready to be used CoLinkEx compatible SWD debugger. User can utilize this link to download code to the PAC5210 device through the CooCox IDE or CoFlash FLASH loader application. Both of these applications, along with the CoLinkEx USB driver, can be downloaded from the www.coocox.org website.

In the event the user desired to utilize a different debugger, connector J1 offers access to the PAC5210 SWD lines. The CoLinkEx debugger must be separated. Separation can be obtained by flipping the S2 DIP switches 3 and 4 to the OFF position.

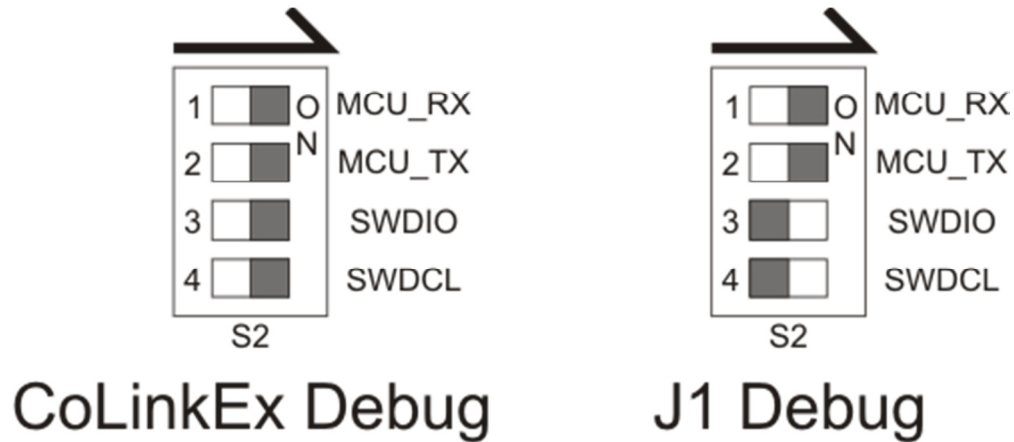

Figure 4 S2 DIP Switch Debugger Selection

The integrated SWD module is powered from the PAC5210's 3.3V regulator.

SWD Jumper/Shunt and Push Button

Jumper	Description
JP1	Used to program U3 microcontroller with CoLinkEx SWD firmware. In Factory use only.
S1	SWD MCU Reset Push Button

The S1 push button resets the SWD MCU. In the event SWD communications are not operational while all voltages are present, pushing the button may restore SWD functionality.

NOTE: It is highly recommended the JP1 to never be populated with a shunt. Doing so will configure the SWD MCU to behave like an USB storage device. This mode is only meant to be employed when programming the SWD MCU with the CoLinkEx firmware.

Serial Communications

The HYDRA-X10 module also contains a fully operational USB to UART serial communications link the user can utilize to communicate with the PAC5210's serial port. This connection is enabled by default at the factory. In the event the user desires to utilize a different serial communications source, the S2 DIP switch must be configured to separate the USB 2 UART resource from the PAC5210 microcontroller.

Figure 5 depicts how to flip the S2 DIP switches 1 and 2 depending on which UART serial communications source is to be employed.

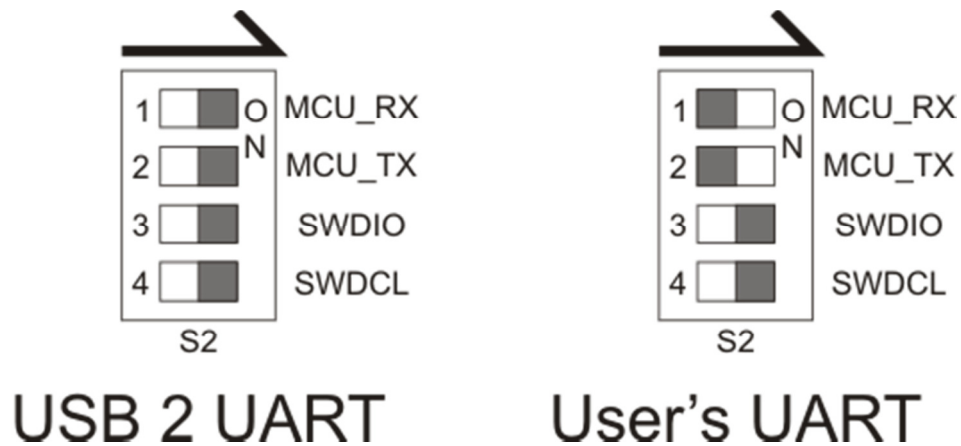

Figure 5 S2 DIP Switch UART Channel Selection

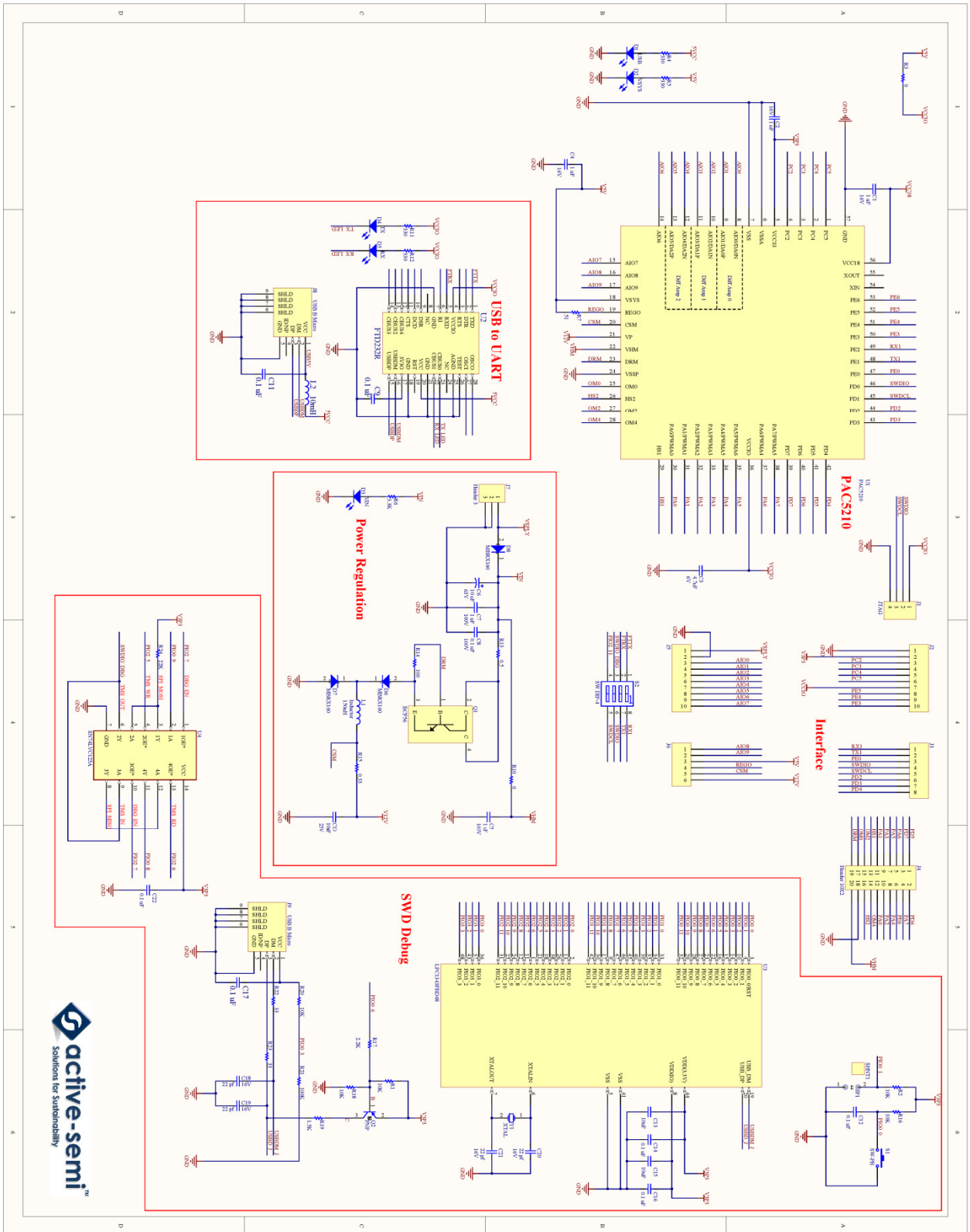

Figure 6:HYDRA-X10 Schematic Diagram

HYDRA-X10 SETUP

The setup for the HYDRA-X10 Body module requires up to three simple connections.

1. Connect the VIN power source via barrel connector J7. When VIN power is present, the LED D3 will light up. If VIN voltage is larger than 16V, the PAC5210's Multi Mode Power Manager will be engaged and the VSYS (5V) regulator will be enabled. This event will result in LED D2 lighting up.
2. Connect the USB Serial Communications to J8: ensure the board's USB cable is connected to a PC computer. LED D1 will light up when the connection is made.
3. Connect the USB SWD to J9. Ensure the board's USB cable is connected to a PC computer. Coccox IDE will signal connection status.

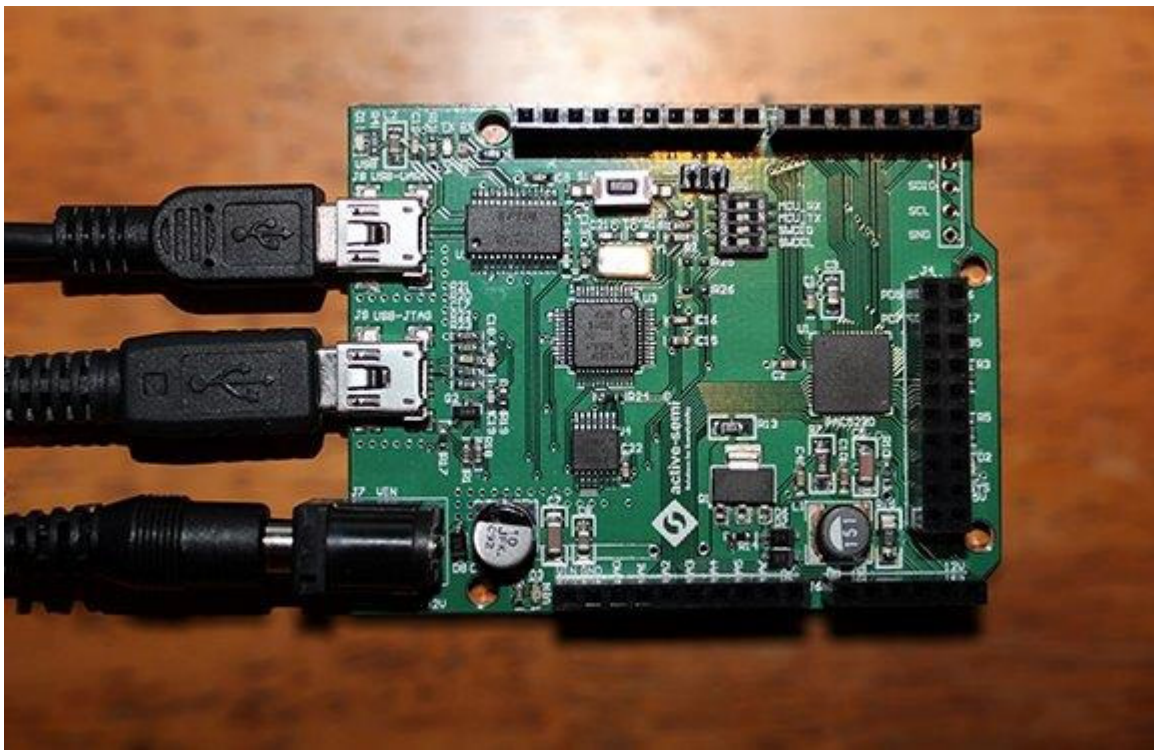

Figure 7:HYDRA-X10 Connections

HYDRA-X HEADS

HYDRA-X Prototype Heads

Active-Semi provides three different prototype heads which allow the HYDRA-X10 Body module to be expanded by the user's applications particular set of requirements. The three prototype heads are named after their size as:

HYDRA-XPROTOS: Small size Prototyping Board (observes the same footprint as the HYDRA-X Body)

HYDRA-XPROTOM: Medium size Prototyping Board (measuring 2.75" x 3.0")

HYDRA-XPROTOL: Large size Prototyping Board (measuring 4" x 4")

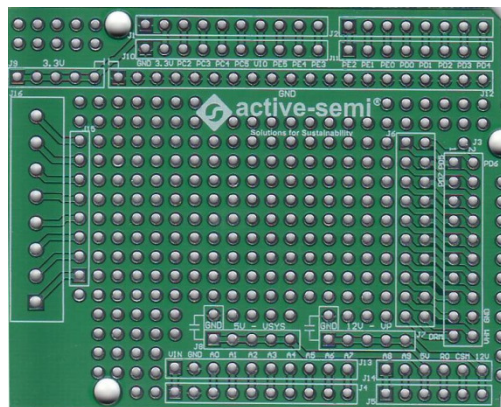

Figure 8 HYDRA-X PROTOS Prototype Board (2.1" x 2.7")

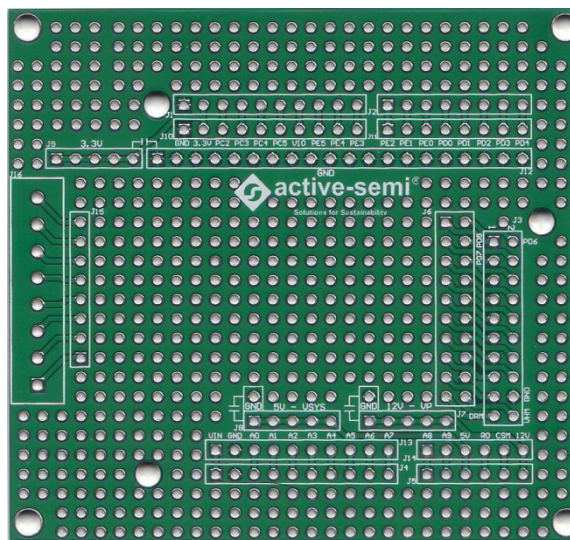

Figure 9 HYDRA-X PROTOM Prototype Board (2.75" x 3")

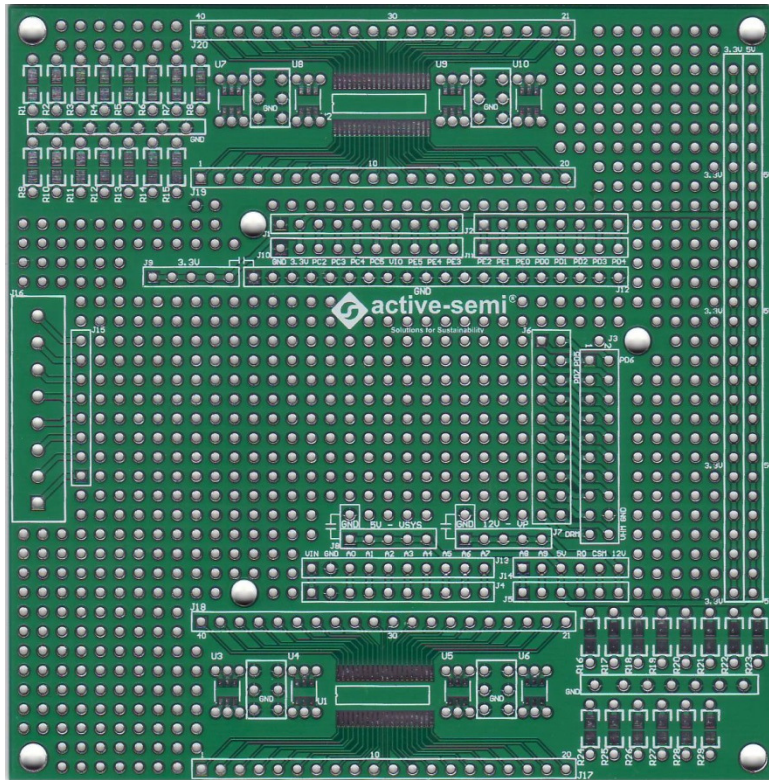

Figure 10HYDRA-X PROTOL Prototype Board (4" x 4")

HYDRA-X Head Design

HYDRA-X10 users can take advantage of the female connectors which accept male header connectors to expand the Body module functionality. Whereas Active-Semi provides a number of existing Heads, users can be exhorted to design their own when possible. Measurements on where mounting holes and interface connectors are to be placed are shown below.

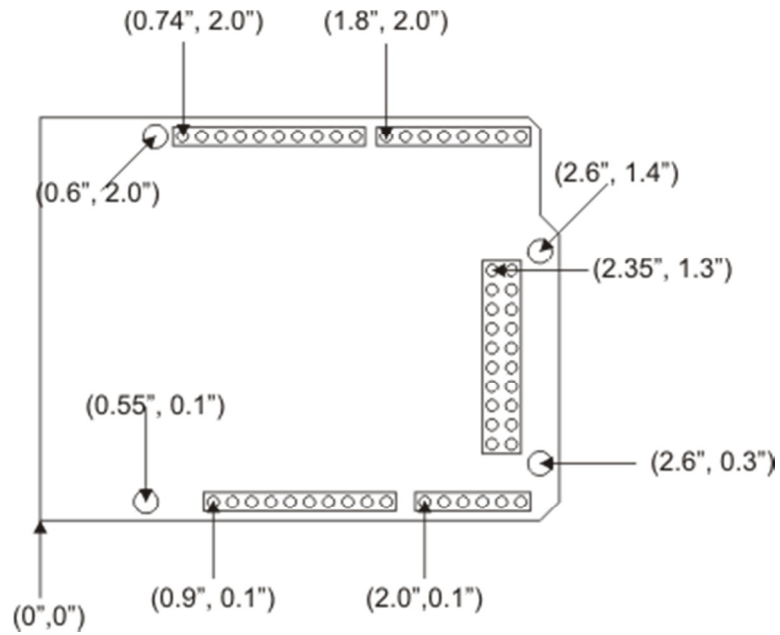

Figure 11 HYDRA-X Floor Plan and Dimensions

ABOUT ACTIVE-SEMI

Founded in 2004 in Silicon Valley and headquartered in Allen, Texas, Active-Semi is a rapidly emerging leader in the multi-billion dollar power management IC and intelligent digital motor drive IC markets. The company's portfolio of analog and mixed signal SoCs (systems-on-chips) are scalable core platforms used in charging, powering and embedded digital control systems for end applications such as industrial, commercial and consumer equipment. The company offers power application microcontrollers, DC/DC, AC/DC, PMU and LED drivers that significantly reduce solution size and cost while improving system-level reliability. Active-Semi's turnkey solutions deliver energy-saving power conversion architectures that minimize energy usage and compress system development cycle-time by greater than 50 percent. Active-Semi ships 50 million power ICs per quarter and reached the "one billion units shipped" milestone in May 2012. The multi-national company focuses on commercializing industry leading power management IC solution platforms and has developed broad intellectual property with over 150 patents granted and pending. For more information visit: <http://active-semi.com/>

LEGAL INFORMATION & DISCLAIMER

Copyright © 2012-2013 Active-Semi, Inc. All rights reserved. All information provided in this document is subject to legal disclaimers.

Active-Semi reserves the right to modify its products, circuitry or product specifications without notice. Active-Semi products are not intended, designed, warranted or authorized for use as critical components in life-support, life-critical or safety-critical devices, systems, or equipment, nor in applications where failure or malfunction of any Active-Semi product can reasonably be expected to result in personal injury, death or severe property or environmental damage. Active-Semi accepts no liability for inclusion and/or use of its products in such equipment or applications. Active-Semi does not assume any liability arising out of the use of any product, circuit, or any information described in this document. No license, express, implied or otherwise, is granted under any patents, copyrights or other intellectual property rights of Active-Semi or others. Active-Semi assumes no liability for any infringement of the intellectual property rights or other rights of third parties which would result from the use of information contained herein. Customers should evaluate each product to make sure that it is suitable for their applications. Customers are responsible for the design, testing, and operation of their applications and products using Active-Semi products. Customers should provide appropriate design and operating safeguards to minimize the risks associated with their applications and products. All products are sold subject to Active-Semi's terms and conditions of sale supplied at the time of order acknowledgment. Exportation of any Active-Semi product may be subject to export control laws.

Active-Semi™, Active-Semi logo, Solutions for Sustainability™, Power Application Controller™, Micro Application Controller™, Multi-Mode Power Manager™, Configurable Analog Front End™, and Application Specific Power Drivers™ are trademarks of Active-Semi, I. ARM® is a registered trademark and Cortex™ is a trademark of ARM Limited. All referenced brands and trademarks are the property of their respective owners.