



Chipsmall Limited consists of a professional team with an average of over 10 year of expertise in the distribution of electronic components. Based in Hongkong, we have already established firm and mutual-benefit business relationships with customers from,Europe,America and south Asia,supplying obsolete and hard-to-find components to meet their specific needs.

With the principle of “Quality Parts,Customers Priority,Honest Operation,and Considerate Service”,our business mainly focus on the distribution of electronic components. Line cards we deal with include Microchip,ALPS,ROHM,Xilinx,Pulse,ON,Everlight and Freescale. Main products comprise IC,Modules,Potentiometer,IC Socket,Relay,Connector.Our parts cover such applications as commercial,industrial, and automotives areas.

We are looking forward to setting up business relationship with you and hope to provide you with the best service and solution. Let us make a better world for our industry!



Contact us

Tel: +86-755-8981 8866 Fax: +86-755-8427 6832

Email & Skype: info@chipsmall.com Web: www.chipsmall.com

Address: A1208, Overseas Decoration Building, #122 Zhenhua RD., Futian, Shenzhen, China



Core **EP10**

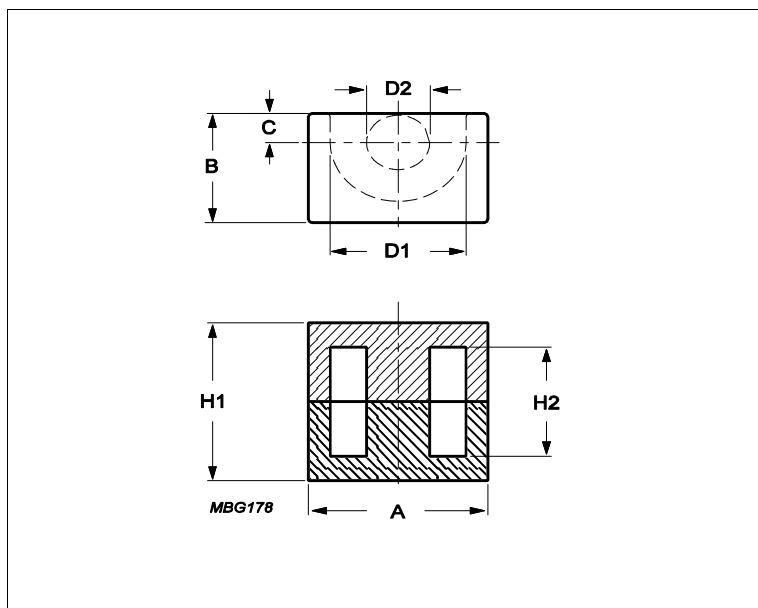

Effective parameters			
	Parameter	Value	Unit
$\Sigma(I/A)$	core factor (C1)	1.7	mm ⁻¹
Ve	effective volume	215	mm ³
Le	effective length	19.3	mm
Ae	effective area	11.3	mm ²
Amin	minimum area	8.55	mm ²
m	EP10	≈ 2.8	g/set

Dimensions for product: EP10

	Nom	Tol +	Tol -	Max	Min	Unit
A	11.50	0.30	0.30	11.80	11.20	mm
B	7.60	0.20	0.20	7.80	7.40	mm
C	1.80	0.13	0.13	1.93	1.67	mm
D1	9.40	0.20	0.20	9.60	9.20	mm
D2	3.30	0.15	0.15	3.45	3.15	mm
H1	10.20	0.20	0.20	10.40	10.00	mm
H2	7.40	0.20	0.20	7.60	7.20	mm

Inductance factor

Material	Value	Tol +	Tol -	Unit
3C91	1200	25%	25%	nH/turns ²
3C96	1000	25%	25%	nH/turns ²
3F36	800	25%	25%	nH/turns ²
3F46	460	25%	25%	nH/turns ²

Power loss: 3C91

Measuring conditions			Max	Unit
100 kHz	200 mT	60 °C	0.110	W/set

Power loss: 3C96

Measuring conditions			Max	Unit
100 kHz	200 mT	100 °C	0.097	W/set
400 kHz	50 mT	100 °C	0.039	W/set

Power loss: 3F36

Measuring conditions			Max	Unit
----------------------	--	--	-----	------

Core **EP10**

Power loss: 3F36

Measuring conditions			Max	Unit
500 kHz	50 mT	100 °C	0.032	W/set
500 kHz	100 mT	100 °C	0.250	W/set

Power loss: 3F46

Measuring conditions			Max	Unit
1000 kHz	50 mT	100 °C	0.086	W/set
3000 kHz	10 mT	100 °C	0.022	W/set

Bsat

Measuring conditions			Material	Min	Unit
25 kHz	250 A/m	100 °C	3C91	320	mT
25 kHz	250 A/m	100 °C	3C96	340	mT
25 kHz	250 A/m	100 °C	3F36	340	mT
25 kHz	250 A/m	100 °C	3F46	330	mT

Accessories

Ordering name	Description	Ordering code
CLA-EP10	Clasp	432202101481
CLI-EP10	Clip	432202100781
CSH-EP10-1S-8P	Coil former, termoset, horizontal	432202100461
CSH-EP10-2S-8P	Coil former, termoset, horizontal	432202100471
CSHS-EP10-1S-8P-T	Coil former, termoset, horizontal, SMD	432202103191
SPR-EP10	Spring	432202101471