



Chipsmall Limited consists of a professional team with an average of over 10 year of expertise in the distribution of electronic components. Based in Hongkong, we have already established firm and mutual-benefit business relationships with customers from,Europe,America and south Asia,supplying obsolete and hard-to-find components to meet their specific needs.

With the principle of "Quality Parts,Customers Priority,Honest Operation,and Considerate Service",our business mainly focus on the distribution of electronic components. Line cards we deal with include Microchip,ALPS,ROHM,Xilinx,Pulse,ON,Everlight and Freescale. Main products comprise IC,Modules,Potentiometer,IC Socket,Relay,Connector.Our parts cover such applications as commercial,industrial, and automotives areas.

We are looking forward to setting up business relationship with you and hope to provide you with the best service and solution. Let us make a better world for our industry!



Contact us

Tel: +86-755-8981 8866 Fax: +86-755-8427 6832

Email & Skype: info@chipsmall.com Web: www.chipsmall.com

Address: A1208, Overseas Decoration Building, #122 Zhenhua RD., Futian, Shenzhen, China



Development Board EPC9001C Quick Start Guide

40 V Half-Bridge with Gate Drive, Using EPC2015C



DESCRIPTION

www.epc-co.com

The EPC9001C development board is a 40 V maximum device voltage, 15 A maximum output current, half bridge with onboard gate drives, featuring the EPC2015C enhancement mode (eGaN®) field effect transistor (FET). The purpose of this development board is to simplify the evaluation process of the EPC2015C eGaN FET by including all the critical components on a single board that can be easily connected into any existing converter.

The EPC9001C development board is 2" x 1.5" and contains two EPC2015Cs eGaN FET in a half bridge configuration using

Texas Instruments LM5113 gate driver, supply and bypass capacitors. The board contains all critical components and layout for optimal switching performance. There are also various probe points to facilitate simple waveform measurement and efficiency calculation. A complete block diagram of the circuit is given in Figure 1.

For more information on the EPC2015Cs eGaN FET please refer to the datasheet available from EPC at www.epc-co.com. The data-sheet should be read in conjunction with this quick start guide.

Table 1: Performance Summary (TA = 25°C)

SYMBOL	PARAMETER	CONDITIONS	MIN	MAX	UNITS
V _{DD}	Gate Drive Input Supply Range		7	12	V
V _{IN}	Bus Input Voltage Range			28*	V
V _{OUT}	Switch Node Output Voltage			40	V
I _{OUT}	Switch Node Output Current			15*	A
V _{PWM}	PWM Logic Input Voltage Threshold	Input 'High'	3.5	6	V
		Input 'Low'	0	1.5	V
	Minimum 'High' State Input Pulse Width	VPWM rise and fall time < 10ns	60		ns
	Minimum 'Low' State Input Pulse Width	VPWM rise and fall time < 10ns	200#		ns

* Assumes inductive load, maximum current depends on die temperature – actual maximum current will be subject to switching frequency, bus voltage and thermal.
 # Limited by time needed to 'refresh' high side bootstrap supply voltage.

Quick Start Procedure

Development board EPC9001C is easy to set up to evaluate the performance of the EPC2015C eGaN FET. Refer to Figure 2. for proper connect and measurement setup and follow the procedure below:

1. With power off, connect the input power supply bus to +V_{IN} (J5, J6) and ground / return to -V_{IN} (J7, J8).
2. With power off, connect the switch node of the half bridge OUT (J3, J4) to your circuit as required.
3. With power off, connect the gate drive supply to +V_{DD} (J1, Pin-1) and ground return to -V_{DD} (J1, Pin-2).
4. With power off, connect the input PWM control signal to PWM (J2, Pin-1) and ground return to any of the remaining J2 pins.
5. Turn on the gate drive supply – make sure the supply is between 7 V and 12 V range.
6. Turn on the bus voltage to the required value (do not exceed the absolute maximum voltage of 100 V on V_{OUT}).
7. Turn on the controller / PWM input source and probe switching node to see switching operation.
8. Once operational, adjust the bus voltage and load PWM control within the operating range and observe the output switching behavior, efficiency and other parameters.
9. For shutdown, please follow steps in reverse.

NOTE. When measuring the high frequency content switch node (OUT), care must be taken to avoid long ground leads. Measure the switch node (OUT) by placing the oscilloscope probe tip through the large via on the switch node (designed for this purpose) and grounding the probe directly across the GND terminals provided. See Figure 3 for proper scope probe technique.

THERMAL CONSIDERATIONS

The EPC9001C development board showcases the EPC2015C eGaN FET. Although the electrical performance surpasses that for traditional silicon devices, their relatively smaller size does magnify the thermal management requirements. The EPC9001C is intended for bench evaluation with low ambient temperature and convection cooling. The addition of heat-sinking and forced air cooling can significantly increase the current rating of these devices, but care must be taken to not exceed the absolute maximum die temperature of 150°C.

NOTE. The EPC2015C development board does not have any current or thermal protection on board.

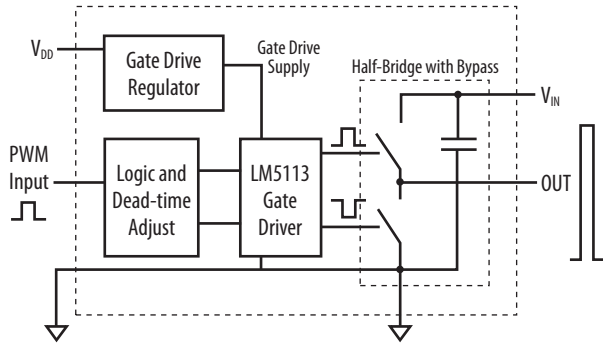

Figure 1: Block Diagram of EPC9001C Development Board

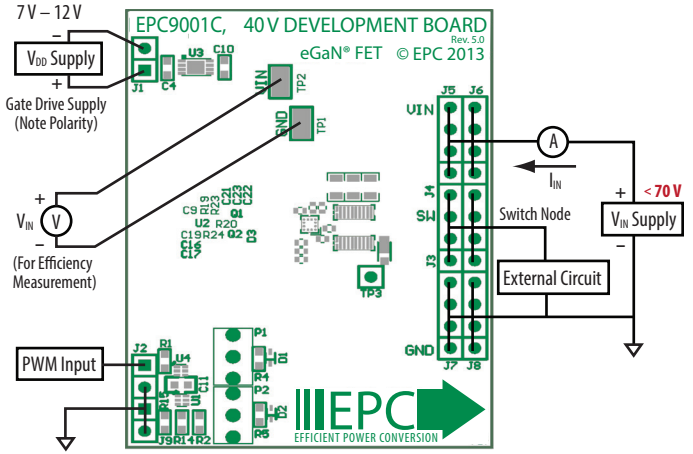

Figure 2: Proper Connection and Measurement Setup

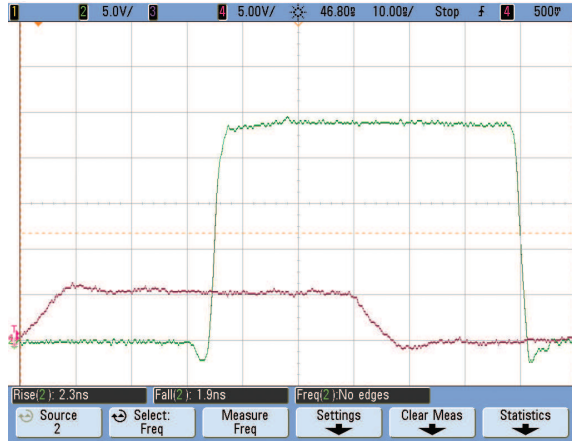

Figure 4: Typical Waveforms for $V_{IN} = 24\text{ V}$ to $1.2\text{ V}/15\text{ A}$ (500 kHz) Buck converter
CH1: V_{PWM} Input voltage – CH3: (I_{out}) Switch node current – CH4: (V_{out}) Switch node voltage

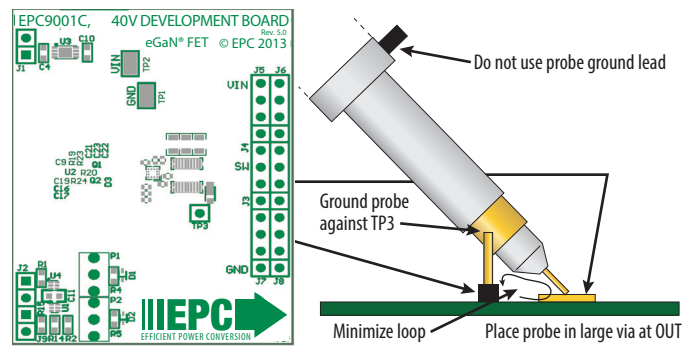
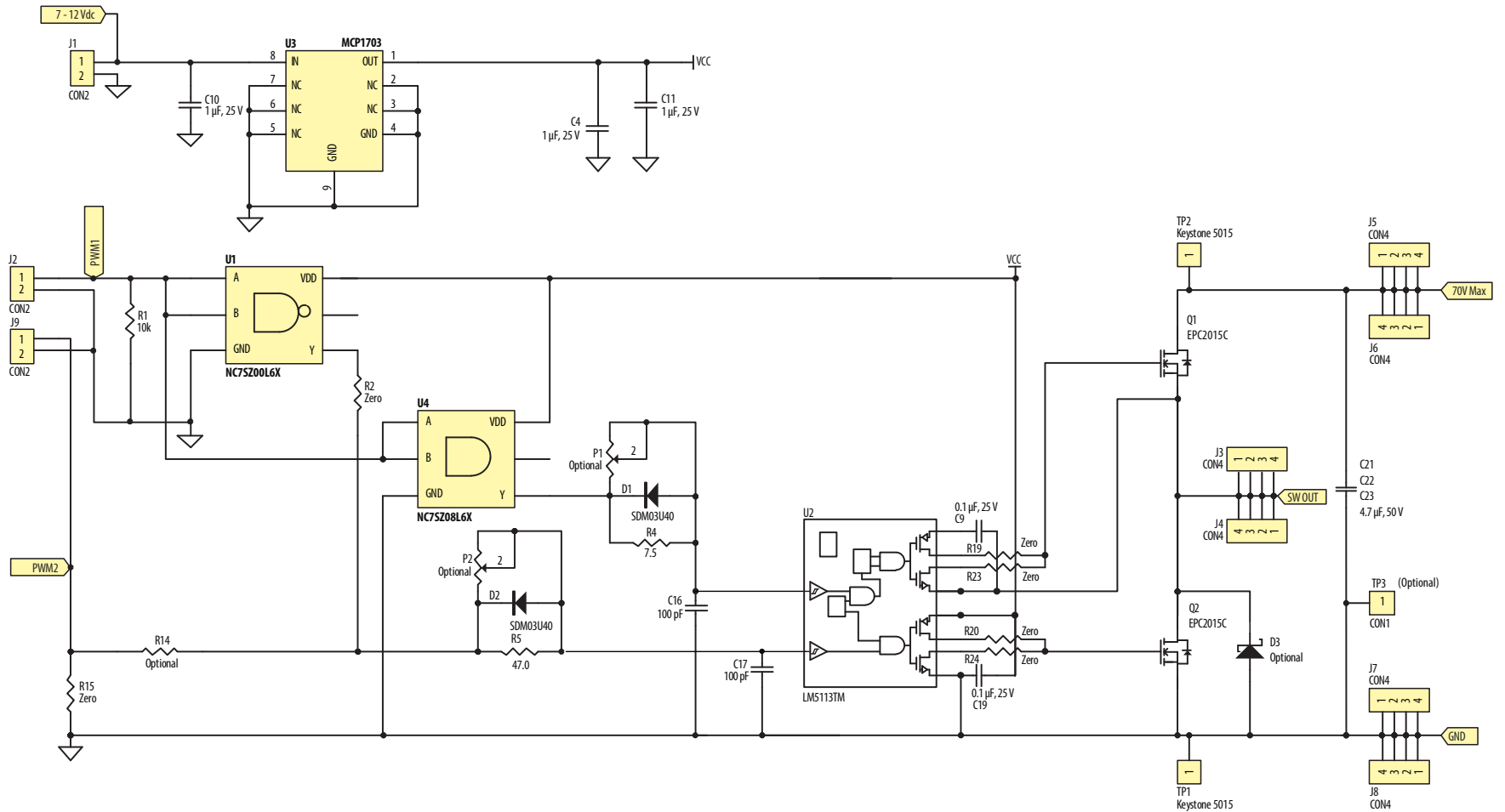

Figure 3: Proper Measurement of Switch Node – OUT

Table 2 : Bill of Material

Item	Qty	Reference	Part Description	Manufacturer / Part #
1	3	C4, C10, C11,	Capacitor, 1 μF , 10%, 25 V, X5R	Murata, GRM188R61E105KA12D
2	2	C16, C17	Capacitor, 100 pF, 5%, 50 V, NP0	Kemet, C0402C101K5GACTU
3	2	C9, C19	Capacitor, 0.1 μF , 10%, 25 V, X5R	TDK, C1005X5R1E104K
4	3	C21, C22, C23	Capacitor, 4.7 μF , 10%, 50 V, X5R	TDK, C2012X5R1H475K125AB
5	2	D1, D2	Schottky Diode, 30 V	Diodes Inc., SDM03U40-7
6	3	J1, J2, J9	Connector	2pins of Tyco, 4-103185-0
7	1	J3, J4, J5, J6, J7, J8	Connector	FCI, 68602-224HLF
8	2	Q1, Q2	eGaN [®] FET	EPC, EPC2015C
9	1	R1	Resistor, 10.0 K, 5%, 1/8 W	Stackpole, RMCF0603FT10K0
10	2	R2, R15	Resistor, 0 Ohm, 1/8 W	Stackpole, RMCF0603ZT0R00
11	1	R4	Resistor, 7.5 Ohm, 1%, 1/8 W	Stackpole, RMCF0603FT7R50
12	1	R5	Resistor, 47 Ohm, 1%, 1/8 W	Stackpole, RMCF0603FT47R0
13	6	R19, R20, R21, R22, R23, R24	Resistor, 0 Ohm, 1/16 W	Stackpole, RMCF0402ZT0R00
14	2	TP1, TP2	Test Point	Keystone Elect, 5015
15	1	TP3	Connector	1/40th of Tyco, 4-103185-0
16	1	U1	I.C., Logic	Fairchild, NC7SZ00L6X
17	1	U2	I.C., Gate driver	Texas Instruments, LM5113TME
18	1	U3	I.C., Regulator	Microchip, MCP1703T-5002E/MC
19	1	U4	I.C., Logic	Fairchild, NC7SZ08L6X
20	0	R14	Optional Resistor	
21	0	D3	Optional Diode	
22	0	P1, P2	Optional Potentiometer	



Development Board EPC9001C Schematic
Rev 5.0

For More Information:

Please contact info@epc-co.com
or your local sales representative

Visit our website:
www.epc-co.com

Sign-up to receive
EPC updates at
bit.ly/EPCupdates
or text "EPC" to 22828



EPC Products are distributed through Digi-Key.
www.digikey.com

Demonstration Board Notification

The EPC9001C boards are intended for product evaluation purposes only and is not intended for commercial use. As an evaluation tool, it is not designed for compliance with the European Union directive on electromagnetic compatibility or any other such directives or regulations. As board builds are at times subject to product availability, it is possible that boards may contain components or assembly materials that are not RoHS compliant. Efficient Power Conversion Corporation (EPC) makes no guarantee that the purchased board is 100% RoHS compliant. No Licenses are implied or granted under any patent right or other intellectual property whatsoever. EPC assumes no liability for applications assistance, customer product design, software performance, or infringement of patents or any other intellectual property rights of any kind.

EPC reserves the right at any time, without notice, to change said circuitry and specifications.