



Chipsmall Limited consists of a professional team with an average of over 10 year of expertise in the distribution of electronic components. Based in Hongkong, we have already established firm and mutual-benefit business relationships with customers from,Europe,America and south Asia,supplying obsolete and hard-to-find components to meet their specific needs.

With the principle of “Quality Parts,Customers Priority,Honest Operation,and Considerate Service”,our business mainly focus on the distribution of electronic components. Line cards we deal with include Microchip,ALPS,ROHM,Xilinx,Pulse,ON,Everlight and Freescale. Main products comprise IC,Modules,Potentiometer,IC Socket,Relay,Connector.Our parts cover such applications as commercial,industrial, and automotives areas.

We are looking forward to setting up business relationship with you and hope to provide you with the best service and solution. Let us make a better world for our industry!



## Contact us

Tel: +86-755-8981 8866 Fax: +86-755-8427 6832

Email & Skype: info@chipsmall.com Web: www.chipsmall.com

Address: A1208, Overseas Decoration Building, #122 Zhenhua RD., Futian, Shenzhen, China



# Development Board EPC9003

## Quick Start Guide

*200 V Half-Bridge with Gate Drive, Using EPC2010*



The EPC9003 development board is a 200 V maximum device voltage, 5 A maximum output current, half bridge with onboard gate drives, featuring the EPC2010 enhancement mode (eGaN®) field effect transistor (FET). The purpose of this development board is to simplify the evaluation process of the EPC2010 eGaN FET by including all the critical components on a single board that can be easily connected into any existing converter.

The EPC9003 development board is 2" x 1.5" and contains not only two EPC2010 eGaN FET in a half bridge configuration with gate

drivers, but also an on board gate drive supply and bypass capacitors. The board contains all critical components and layout for optimal switching performance. There are also various probe points to facilitate simple waveform measurement and efficiency calculation. A complete block diagram of the circuit is given in Figure 1.

For more information on the EPC2010s eGaN FET please refer to the datasheet available from EPC at [www.epc-co.com](http://www.epc-co.com). The datasheet should be read in conjunction with this quick start guide.

**Table 1** Performance Summary ( $T_A = 25^\circ\text{C}$ )

SYMBOL	PARAMETER	CONDITIONS	MIN	MAX	UNITS
$V_{DD}$	Gate Drive Input Supply Range		7	12	V
$V_{IN}$	Bus Input Voltage Range			150	V
$V_{OUT}$	Switch Node Output Voltage			200	V
$I_{OUT}$	Switch Node Output Current			5*	A
$V_{PWM}$	PWM Logic Input Voltage Threshold	Input 'High'	3.5	6	V
		Input 'Low'	0	1.5	V
	Minimum 'High' State Input Pulse Width	VPWM rise and fall time < 10ns	60		ns
	Minimum 'Low' State Input Pulse Width	VPWM rise and fall time < 10ns	500#		ns

\*Assumes inductive load, maximum current depends on die temperature – actual maximum current will be subject to switching frequency, bus voltage and thermal.

# Dependent on time needed to 'refresh' high side bootstrap supply voltage.

## Quick Start Procedure

Development board EP9003 is easy to set up to evaluate the performance of the EP2010 eGaN FET. Refer to Figure 2 for proper connect and measurement setup and follow the procedure below:

1. With power off, connect the input power supply bus to +VIN (J5, J6) and ground / return to -VIN (J7, J8).
2. With power off, connect the switch node of the half bridge OUT (J3, J4) to your circuit as required.
3. With power off, connect the gate drive input to +VDD (J1, Pin-1) and ground return to -VDD (J1, Pin-2).
4. With power off, connect the input PWM control signal to PWM (J2, Pin-1) and ground return to any of the remaining J2 pins.
5. Turn on the gate drive supply – make sure the supply is between 7 V and 12 V range.
6. Turn on the bus voltage to the required value (do not exceed the absolute maximum voltage of 200 V on VOUT).
7. Turn on the controller / PWM input source and probe switching node to see switching operation.
8. Once operational, adjust the bus voltage and load PWM control within the operating range and observe the output switching behavior, efficiency and other parameters.
9. For shutdown, please follow steps in reverse.

NOTE: When measuring the high frequency content switch node (OUT), care must be taken to avoid long ground leads. Measure the switch node (OUT) by placing the oscilloscope probe tip through the large via on the switch node (designed for this purpose) and grounding the probe directly across the GND terminals provided. See Figure 3 for proper scope probe technique.

## THERMAL CONSIDERATIONS

The EP9003 development board showcases the EP2010 eGaN FET. Although the electrical performance surpasses that for traditional Si devices, their relatively smaller size does magnify the thermal management requirements. The EP9003 is intended for bench evaluation with low ambient temperature and convection cooling. The addition of heat-sinking and forced air cooling can significantly increase the current rating of these devices, but care must be taken to not exceed the absolute maximum die temperature of 125°C.

NOTE: The EP9003 development board does not have any current or thermal protection on board.

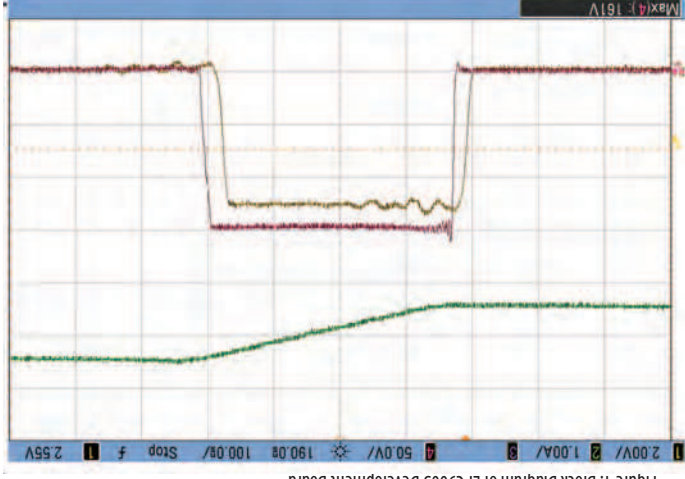

Figure 4: Waveforms for  $V_m = 150\text{ V}$  to  $5\text{ V/5 A}$  (100kHz) Buck converter  
 CH1:  $V_m^{\text{PM}}$  Input voltage – CH2:  $(I^{\text{OUT}})$  Switch node current – CH3:  $(V^{\text{OUT}})$  Switch node voltage

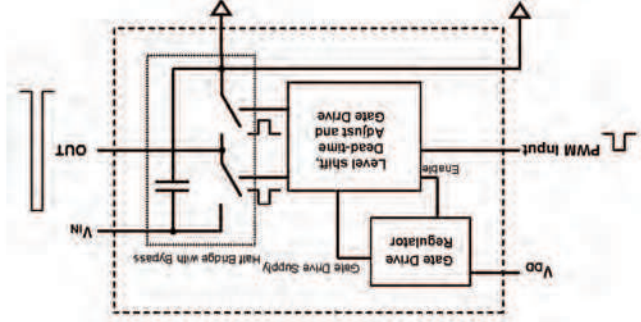

Figure 1: Block Diagram of EP9003 Development Board

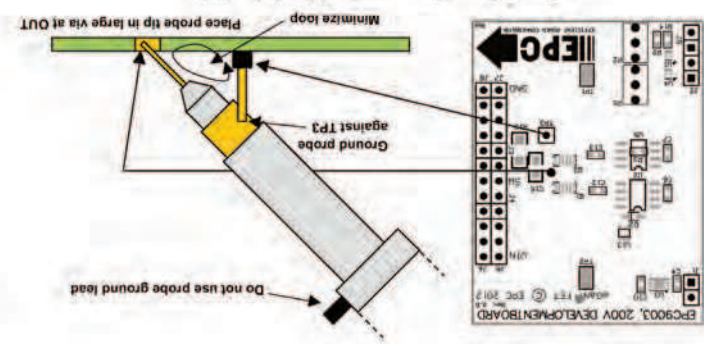
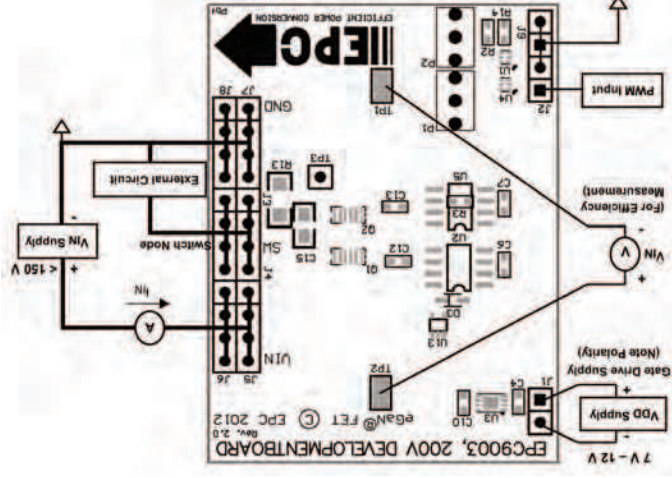

Figure 3: Proper Measurement of Switch Node – OUT

Figure 2: Proper Connection and Measurement Setup



**Table 2 : Bill of Material**

Item	Qty	Reference	Part Description	Manufacturer / Part #
1	7	C2, C3, C4, C10, C11, C12, C13	Capacitor, 1uF, 10%, 25V, X5R	Murata, GRM188R61E105KA12D
2	2	C6, C7	Capacitor, 100pF, 5%, 50V, NP0	TDK, C1608C0G1H101J
3	2	C16, C17	Capacitor, .33uF, 20%, 250V, X7R	TDK, C4532X7R2E334M
4	2	D1, D2	Schottky Diode, 30V	Diodes Inc., SDM03U40-7
5	2	D3	Diode, 200V	Diodes Inc., BAV21WS-7-F
6	1	J1	Connector	2pins of Tyco, 4-103185-0
7	1	J2	Connector	4pins of Tyco, 4-103185-0
8	1	J3, J4, J5, J6, J7, J8	Connector	FCI, 68602-224HLF
9	2	Q1, Q2	eGaN FET	EPC, EPC2010
10	1	R1	Resistor, 10.0K, 5%, 1/8W	Stackpole, RMCF0603FT10K0
11	2	R11, R12	Resistor, 1 Ohm, 1%, 1/8W	Stackpole, RMCF0603FT1R00
12	4	R2, R3, R4, R15	Resistor, 0 Ohm, 1/8W	Stackpole, RMCF0603FT00R0
13	1	R5	Resistor, TBD, 390 Ohm, 1%, 1/8W	Stackpole, RMCF0603FT390R
14	2	TP1, TP2	Test Point	Keystone Elect, 5015
15	1	TP3	Connector	1/40th of Tyco, 4-103185-0
16	1	U1	I.C., Logic	Fairchild, NC7SZ00L6X
17	1	U2	I.C., Opto-coupler	Silicon Labs, Si8410BB
18	1	U3	I.C., Regulator	Microchip, MCP1703T-5002E/MC
19	1	U4	I.C., Logic	Fairchild, NC7SZ08L6X
20	2	U6, U7	I.C., Gate driver	Texas Instruments, LM5114
21	0	C15, C18	Optional capacitor	
22	0	D5	Optional diode	
23	0	P1, P2	Optional Potentiometer	
24	0	R13, R14	Optional resistor	
25	0	U5, U13	Optional I.C.	

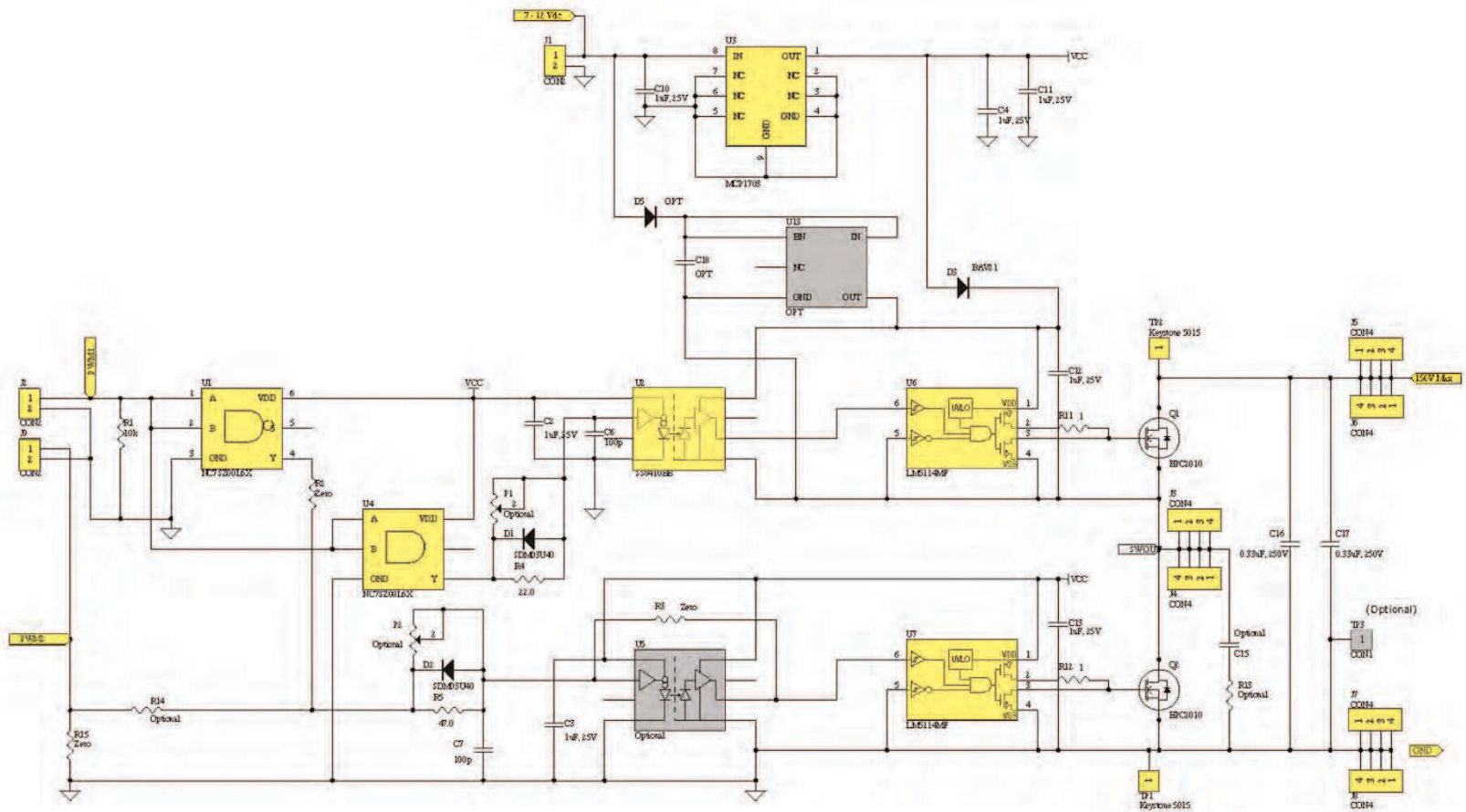

200V Half-Bridge with Gate Drive, using EPC2010  
Rev 2.0

## Contact us:

[www.epc-co.com](http://www.epc-co.com)

### **Renee Yawger WW Marketing**

Office: +1.908.475.5702  
Mobile: +1.908.619.9678  
renee.yawger@epc-co.com

### **Stephen Tsang Sales, Asia**

Mobile: +852.9408.8351  
stephen.tsang@epc-co.com

### **Bhasy Nair Global FAE Support**

Office: +1.972.805.8585  
Mobile: +1.469.879.2424  
bhasy.nair@epc-co.com

### **Peter Cheng FAE Support, Asia**

Mobile: +886.938.009.706  
peter.cheng@epc-co.com



EPC Products are distributed exclusively through Digi-Key.  
[www.digikey.com](http://www.digikey.com)

#### **Development Board / Demonstration Board Notification**

The EPC9003 board is intended for product evaluation purposes only and is not intended for commercial use. As an evaluation tool, it is not designed for compliance with the European Union directive on electromagnetic compatibility or any other such directives or regulations.

As board builds are at times subject to product availability, it is possible that boards may contain components or assembly materials that are not RoHS compliant. Efficient Power Conversion Corporation (EPC) makes no guarantee that the purchased board is 100% RoHS compliant.

No Licenses are implied or granted under any patent right or other intellectual property whatsoever. EPC assumes no liability for applications assistance, customer product design, software performance, or infringement of patents or any other intellectual property rights of any kind.

EPC reserves the right at any time, without notice, to change said circuitry and specifications.