



Chipsmall Limited consists of a professional team with an average of over 10 year of expertise in the distribution of electronic components. Based in Hongkong, we have already established firm and mutual-benefit business relationships with customers from,Europe,America and south Asia,supplying obsolete and hard-to-find components to meet their specific needs.

With the principle of “Quality Parts,Customers Priority,Honest Operation,and Considerate Service”,our business mainly focus on the distribution of electronic components. Line cards we deal with include Microchip,ALPS,ROHM,Xilinx,Pulse,ON,Everlight and Freescale. Main products comprise IC,Modules,Potentiometer,IC Socket,Relay,Connector.Our parts cover such applications as commercial,industrial, and automotives areas.

We are looking forward to setting up business relationship with you and hope to provide you with the best service and solution. Let us make a better world for our industry!



Contact us

Tel: +86-755-8981 8866 Fax: +86-755-8427 6832

Email & Skype: info@chipsmall.com Web: www.chipsmall.com

Address: A1208, Overseas Decoration Building, #122 Zhenhua RD., Futian, Shenzhen, China



Development Board EPC9086 Quick Start Guide

Half-Bridge with Gate Drive, Using EPC2111

Revision 1.0

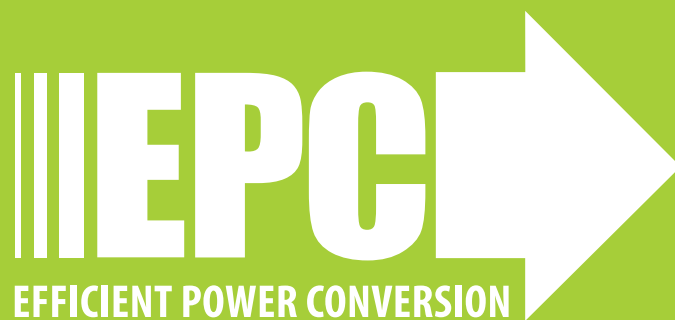

DESCRIPTION

The EPC9086 development board provides a half bridge configuration with onboard gate drives, featuring the EPC2111 eGaNIC (Enhancement-mode Gallium Nitride Integrated Circuit). The purpose of this development board is to simplify the evaluation process of the EPC2111 eGaNIC by including all the critical components on a single board that can be easily connected into any existing converter.

The EPC9086 development board is 2" x 2" and contains an EPC2111 eGaNIC in combination with the Peregrine Semiconductor [PE29102](#) gate driver. The board also contains all critical components and layout for optimal switching performance. There are also various probe points to facilitate simple waveform measurement and efficiency calculation. A block diagram of the circuit is given in figure 1.

For more information on the EPC2111 please refer to the datasheet available from EPC at www.epc-co.com. The datasheet should be read in conjunction with this quick start guide.

QUICK START PROCEDURE

Development board EPC9086 is easy to set up to evaluate the performance of the EPC2111 eGaNIC. Refer to figure 2 for proper connect and measurement setup and follow the procedure below:

1. With power off, connect the input power supply bus to +VIN (J5, J6) and ground / return to -VIN (J7, J8).
2. With power off, connect the switch node (SW) of the half bridge OUT (J3, J4) to your circuit as required (half bridge configuration). The EPC9086 features an optional buck converter configuration, as shown in figure 2, with unpopulated footprints for an output inductor and output capacitors.
3. With power off, connect the gate drive input to +VDD (J1) and ground return to -VDD (J1) as shown in figure 2.
4. With power off, connect the input PWM control signal to PWM (J2) and ground return (J2) as shown in figure 2.
5. Turn on the gate drive supply – make sure the supply is between 7.5 V and 12 V range.
6. Turn on the controller / PWM input source.
7. Turn on the bus voltage to the required value (do not exceed the absolute maximum voltage) and probe switching node to see switching operation.
8. Once operational, adjust the PWM control, bus voltage, and load within the operating range and observe the output switching behavior, efficiency and other parameters.
9. For shutdown, please follow steps in reverse.

Symbol	Parameter	Conditions	Min	Max	Units
V _{DD}	Gate Drive Input Supply Range		7.5	12	V
V _{IN}	Bus Input Voltage Range ⁽¹⁾			20	V
I _{OUT}	Switch Node Output Current ⁽²⁾			15	A
V _{PWM}	PWM Logic Input Voltage Threshold	Input 'High' Input 'Low'	3.5 0	6 1.5	V V
	Minimum 'High' State Input Pulse Width	V _{PWM} rise and fall time < 10 ns	5		ns

(1) Maximum input voltage depends on inductive loading, maximum switch node ringing must be kept under 30 V for EPC2111. (2) Maximum current depends on die temperature – actual maximum current will be subject to switching frequency, bus voltage and thermal cooling.

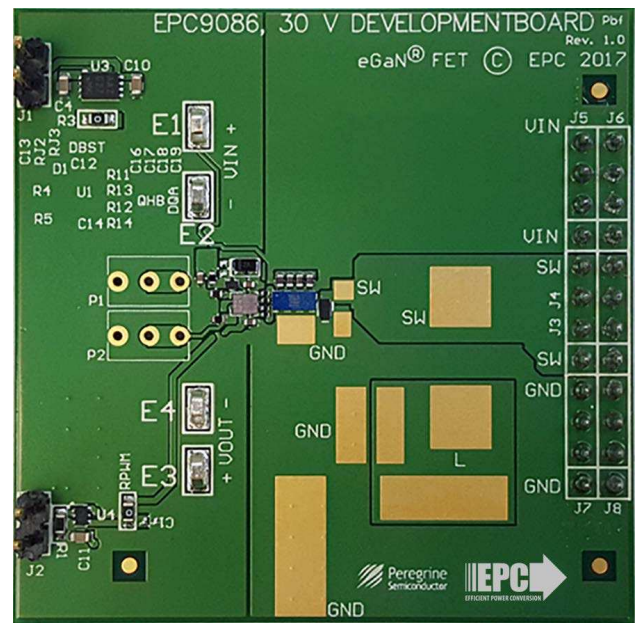

EPC9086 board.

NOTE. When measuring the high frequency content switch node, care must be taken to provide an accurate high speed measurement. Switch node measurement points are located on the top and bottom sides of the EPC9086 board. It is recommended, if possible, to install the measurement point on the backside of board to prevent contamination of the top side components.

For information about measurement techniques, please review application note AN023: Accurately Measuring High Speed GaN Transistors:

<http://epc-co.com/epc/DesignSupport/ApplicationNotes.aspx>

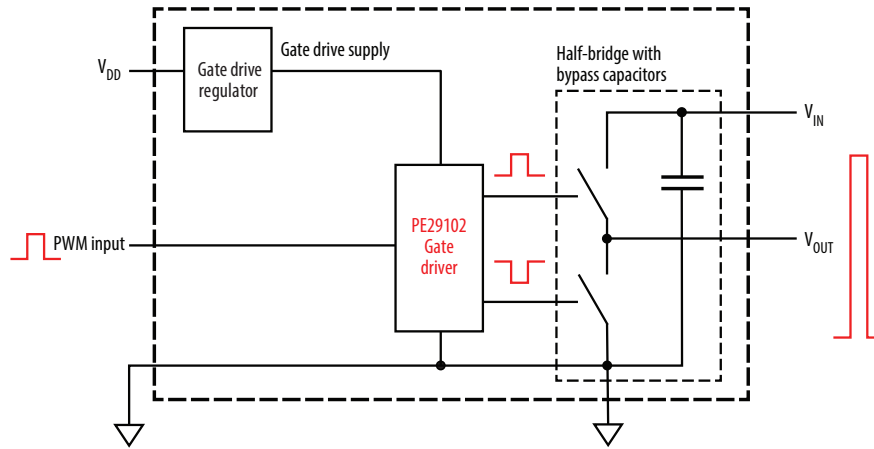

Figure 1: Block diagram of EPC9086 development board.

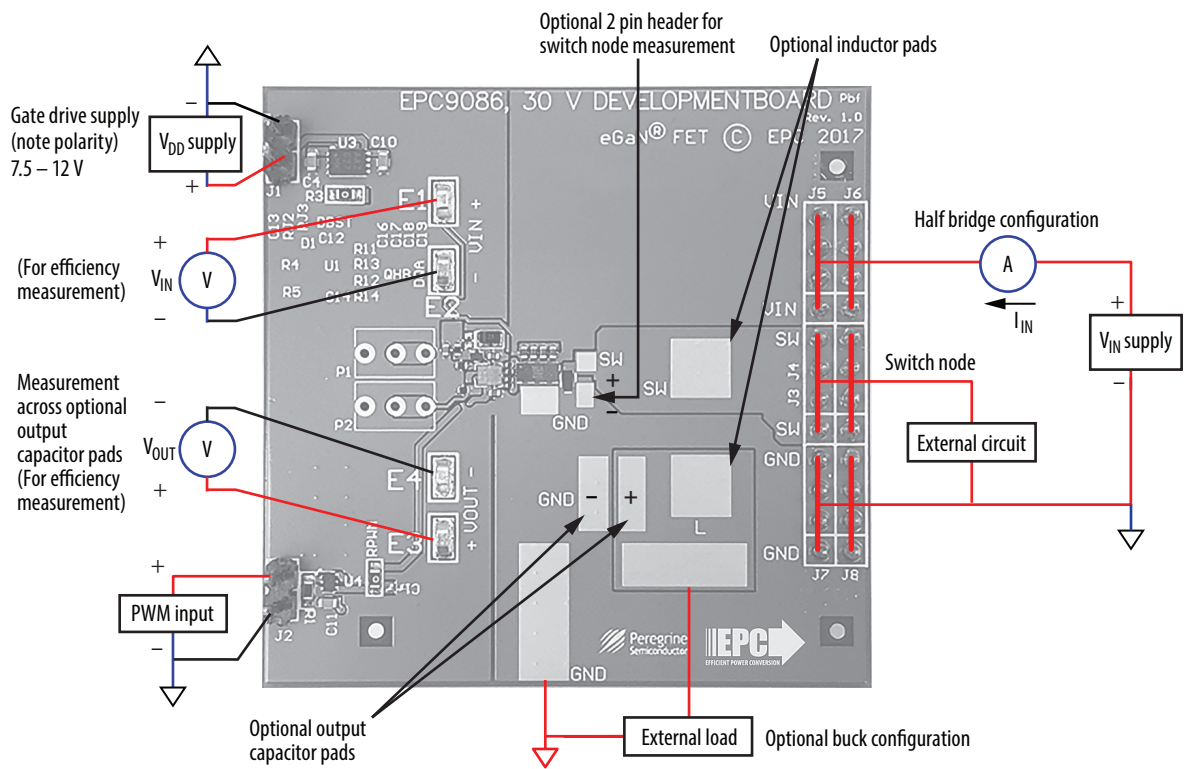
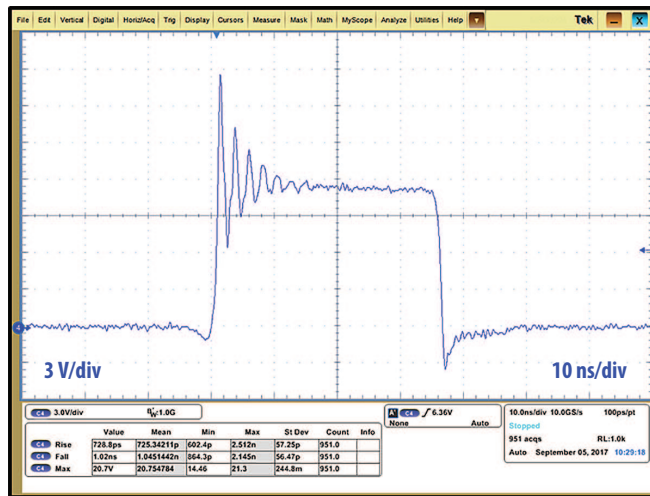
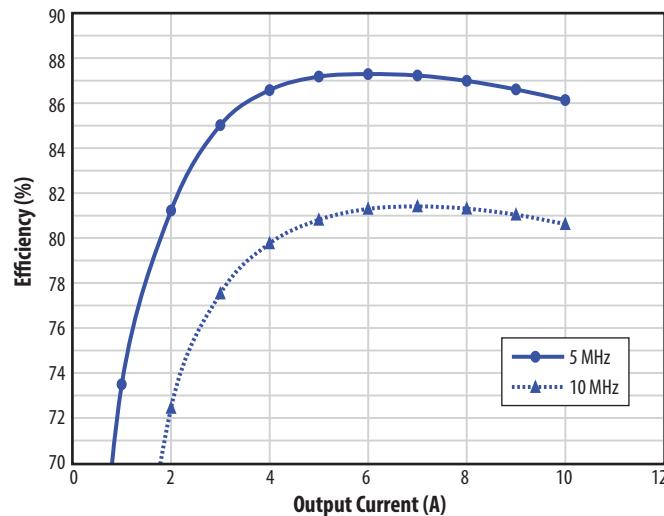

Figure 2: Proper connection and measurement setup.



$V_{IN} = 12\text{ V}, V_{OUT} = 1.8\text{ V}, I_{OUT} = 10\text{ A}, f_{SW} = 5\text{ MHz}$

Figure 3: Typical waveform for $V_{IN} = 12\text{ V}$ to 1.8 V_{OUT} , 10 A (5 MHz) buck converter.



$V_{IN} = 12\text{ V}, V_{OUT} = 1.8\text{ V}, L = \text{IHLP-2525BD-01 } 100\text{ nH}$

Figure 4: Typical system efficiency for $V_{IN} = 12\text{ V}$ to 1.8 V_{OUT} buck converter .

THERMAL CONSIDERATIONS

The EPC9086 development board showcases the EPC2111 eGaN FET. The EPC9086 is intended for bench evaluation with low ambient temperature and convection cooling. The addition of heat-sinking and forced air cooling can significantly increase the current rating of these devices, but care must be taken to not exceed the absolute maximum die temperature of 150°C.

NOTE. The EPC9086 development board does not have any current or thermal protection on board.

For more information regarding the thermal performance of EPC eGaN FETs, please consult:

D. Reusch and J. Glaser, *DC-DC Converter Handbook*, a supplement to *GaN Transistors for Efficient Power Conversion*, First Edition, Power Conversion Publications, 2015.

EPC9086 BOM				
Item	Qty	Reference	Part Description	Manufacturer/Part Number
1	3	C4, C10, C11	Capacitor, 1 µF, 10%, 25 V, X5R	Murata, GRM188R61E105KA12D
2	1	C12	Capacitor, 0.1 µF, 10%, 25 V, X5R	TDK, C1005X5R1E104K050BC
3	2	C13, C14	Capacitor, 1 µF, 10%, 25 V, X5R	TDK, C1005X5R1E105K050BC
4	4	C16, C17, C18, C19	Capacitor, 2.2 µF, 20%, 25 V, X5R	TDK, C1005X5R1E225M050BC
5	2	D1	Schottky Diode, 40 V	Diodes Inc, BAS40LP-7
6	1	DBST	Zener Diode, 5.1 V, 150 mW	Bourns Inc, CD0603-Z5V1
7	1	DQA	Schottky Diode 30 V 2 A 30 V 2 A X3-WLB1608-2	Diodes INC, SDM2U30CSP-7
8	1	QHB	eGaN IC, 30 V Half Bridge	EPC, EPC2111
9	1	R1	Resistor, 10.0 kΩ 5%, 1/8 W	Stackpole, RMCF0603FT10K0
10	2	R3, RPWM	Resistor, 0 Ω, 1/8 W, 0603	Panasonic, ERJ-3GEY0R00V
11	1	R4	Resistor, 59 kΩ 1%, 1/10 W	Panasonic, ERJ-2RKF5902X
12	1	R5	Resistor, 35.7 kΩ 1%, 1/16 W	Stackpole, RMCF0402FT35K7
13	4	R11, R12, R13, R14	Resistor, 0 Ω Jumper, 1/20 W	Panasonic, ERJ-1GN0R00C
14	1	U1	Gate Driver, PE29102	Murata/Peregrine, PE29102
15	1	U3	Linear Regulator, MCP1703T-5002E/MC	Microchip, MCP1703T-5002E/MC
16	1	U4	IC Gate AND 1CH 2-INP 6-MICROPAK	Fairchild, NC7SZ08L6X
17	6	J3, J4, J5, J6, J7, J8	FCI, 68602-224HLF	FCI, 68602-224HLF
18	2	J1, J2	2 pins of Tyco, 4-103185-0	2pins of Tyco, 4-103185-0
19	2	E1, E2, E3, E4	Keystone Elect, 5015	Keystone Elect, 5015
20	2	RJ1, RJ2	Resistor, 0 Ω JUMPER, 1/16 W	Yageo, RC0402JR-070RL

Optional Components					
Item	Qty	Reference	Part Description	Manufacturer	Part #
1	DNP	C1	Filter Capacitor		
2	DNP	P1, P2	Optional Potentiometer		
3	DNP	FD1, FD2, FD3	PCB Fiducial		
4	DNP	C21	Input Capacitor		
5	DNP	RJ3	Resistor, Jumper		

For More Information:

Please contact info@epc-co.com
or your local sales representative

Visit our website:
www.epc-co.com

Sign-up to receive
EPC updates at
bit.ly/EPCupdates
or text "EPC" to 22828



EPC Products are distributed through Digi-Key.
www.digikey.com

Demonstration Board Warning and Disclaimer

The EPC9086 board is intended for product evaluation purposes only and is not intended for commercial use. Replace components on the Evaluation Board only with those parts shown on the parts list (or Bill of Materials) in the Quick Start Guide. Contact an authorized EPC representative with any questions.

This board is intended to be used by certified professionals, in a lab environment, following proper safety procedures. Use at your own risk.

As an evaluation tool, this board is not designed for compliance with the European Union directive on electromagnetic compatibility or any other such directives or regulations. As board builds are at times subject to product availability, it is possible that boards may contain components or assembly materials that are not RoHS compliant. Efficient Power Conversion Corporation (EPC) makes no guarantee that the purchased board is 100% RoHS compliant.

The Evaluation board (or kit) is for demonstration purposes only and neither the Board nor this Quick Start Guide constitute a sales contract or create any kind of warranty, whether express or implied, as to the applications or products involved.

Disclaimer: EPC reserves the right at any time, without notice, to make changes to any products described herein to improve reliability, function, or design. EPC does not assume any liability arising out of the application or use of any product or circuit described herein; neither does it convey any license under its patent rights, or other intellectual property whatsoever, nor the rights of others.