



Chipsmall Limited consists of a professional team with an average of over 10 year of expertise in the distribution of electronic components. Based in Hongkong, we have already established firm and mutual-benefit business relationships with customers from,Europe,America and south Asia,supplying obsolete and hard-to-find components to meet their specific needs.

With the principle of “Quality Parts,Customers Priority,Honest Operation,and Considerate Service”,our business mainly focus on the distribution of electronic components. Line cards we deal with include Microchip,ALPS,ROHM,Xilinx,Pulse,ON,Everlight and Freescale. Main products comprise IC,Modules,Potentiometer,IC Socket,Relay,Connector.Our parts cover such applications as commercial,industrial, and automotives areas.

We are looking forward to setting up business relationship with you and hope to provide you with the best service and solution. Let us make a better world for our industry!



Contact us

Tel: +86-755-8981 8866 Fax: +86-755-8427 6832

Email & Skype: info@chipsmall.com Web: www.chipsmall.com

Address: A1208, Overseas Decoration Building, #122 Zhenhua RD., Futian, Shenzhen, China



Demonstration Board EPC9115 Quick Start Guide

1/8th Brick Converter
Featuring EPC2020 and EPC2021

For More Information:

Please contact info@epc-co.com
or your local sales representative

Visit our website:
www.epc-co.com

Sign-up to receive
EPC updates at
bit.ly/EPCupdates
or text "EPC" to 22828



EPC Products are distributed
through Digi-Key.
www.digikey.com



DESCRIPTION

The EPC9115 demonstration board is a fully regulated 300 kHz isolated DC/DC bus converter with a 12 V, 42 A output and an input range of 48 – 60 V. The demonstration board features the enhancement mode (eGaN®) field effect transistors (FETs), the EPC2020 (60 V) and EPC2021 (80 V), along with eGaN FET specific integrated circuit drivers – the LM5113 half-bridge driver and UCC27611 low side driver from Texas Instruments. The power stage is a conventional hard-switched 300 kHz isolated buck converter. The EPC9115 board is intended to showcase the superior performance that can be achieved using eGaN FETs and eGaN driver together in a conventional topology.

The complete converter fits within a standard eighth-brick envelope, but the demonstration board is oversized to allow connections for bench evaluation. There are also various probe points to facilitate simple waveform measurement and efficiency calculation.

A complete block diagram of the circuit is given in Figure 1. The converter uses a full-bridge (FB) primary power stage, a 4:1 transformer, and a center-tapped (CT) output stage with active reset snubbers. Control is provided by a Microchip dsPIC® controller, and basic voltage mode control is implemented. For more information on the EPC2020 and EPC2021 eGaN FETs, as well as the gate drivers and controller, please refer to the datasheets available from EPC at www.epc-co.com, www.ti.com, and www.microchip.com. These datasheets, should be read in conjunction with this quick start guide.

Table 1: Performance Summary ($V_{IN}=52\text{ V}$, $T_A = 25^\circ\text{C}$, 400 LFM unless otherwise specified)

SYMBOL	PARAMETER	CONDITIONS	MIN	TYP	MAX	UNITS
V_{IN}	Bus Input Voltage Range		48	52	60	V
V_{OUT}	Output Voltage		11.4 ¹	12	12.1	V
I_{OUT}	Output Current ²	$T_a = 25^\circ\text{C}$, no forced air cooling ³			5	A
		$T_a = 25^\circ\text{C}$, ~200 LFM			35	A
		$T_a = 25^\circ\text{C}$, ~400 LFM			42	A
f_{SW}	Switching Frequency			300		kHz
	Output Ripple Frequency			600		kHz
	Peak Efficiency	48 V_{IN} , 30 A I_{OUT}		96.7		%
	Full Load Efficiency	52 V_{IN} , 42 A I_{OUT}		96.4		%
	Full Load Efficiency	56 V_{IN} , 42 A I_{OUT}		96.3		%
	Full Load Efficiency	60 V_{IN} , 42 A I_{OUT}		96.1		%

¹ Output voltage duty cycle limited to 98%

² Maximum current limited by thermal considerations

³ Board placed vertical on long edge to aid convection – Do NOT operate horizontally without forced air cooling

Demonstration Board Notification

EPC9115 boards are intended for product evaluation purposes only and are not intended for commercial use. As evaluation tools, they are not designed for compliance with the European Union directive on electromagnetic compatibility or any other such directives or regulations. As board builds are at times subject to product availability, it is possible that boards may contain components or assembly materials that are not RoHS compliant. Efficient Power Conversion Corporation (EPC) makes no guarantee that the purchased board is 100% RoHS compliant. No Licenses are implied or granted under any patent right or other intellectual property whatsoever. EPC assumes no liability for applications assistance, customer product design, software performance, or infringement of patents or any other intellectual property rights of any kind.

EPC reserves the right at any time, without notice, to change said circuitry and specifications.

QUICK START PROCEDURE

Demonstration board EPC9115 is easy to set up to evaluate the performance of the EPC2020 and EPC2021 eGaN FETs and LM5113 and UCC27611 drivers. Refer to Figure 2 for proper connect and measurement setup and follow the procedure below:

1. With power off, connect the input power supply bus between V_{IN+} and V_{IN-} euro connectors as shown.
2. Add input and output voltage measurements to the Kelvin connections provided as shown.
3. With power off, connect the load as desired between V_{OUT+} and V_{OUT-} euro connectors as shown. A resistive or constant current load is recommended.
4. Turn on the supply voltage to the required value. Do not exceed the absolute maximum voltage of 60 V on V_{IN} .
5. Measure the output voltage to make sure the board is fully functional and operating no-load.

6. Turn on active load and adjust to the desired load current while staying below the maximum current (This will depend on the cooling provided. If no forced air cooling, then keep the load current below 5 A).
7. If testing under moderate to full load conditions, ensure that a fan or other source of forced convection is producing adequate airflow (≥ 400 LFM recommended for full load operation).
8. Once operational, adjust the bus voltage and load current within the allowed operating range and observe the output switching behavior, efficiency and other parameters.
9. For shutdown, please follow steps in reverse.

NOTE: For accurate high frequency content switch node and gate voltage waveforms, use a short ground clip or purpose-made probe adapter, as shown in Fig. 3. Avoid long ground leads on oscilloscope probes. **Please note that primary and secondary side grounds are not connected to each other on the EPC9115 demo board.** When measuring multiple signals ensure that they are always referenced to the same 'ground' potential to avoid potential circuit failure or instrumentation failure.

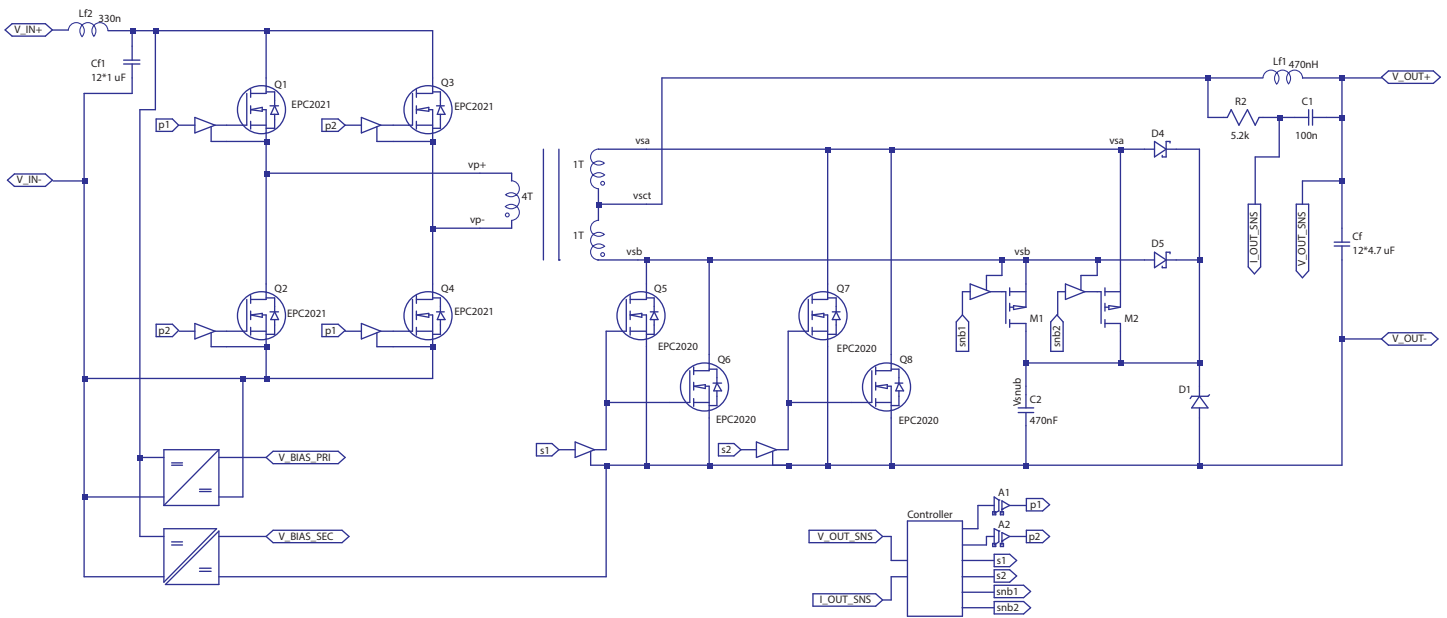

Figure 1: Block Diagram of EPC9115 Demonstration Board

QUICK START PROCEDURE

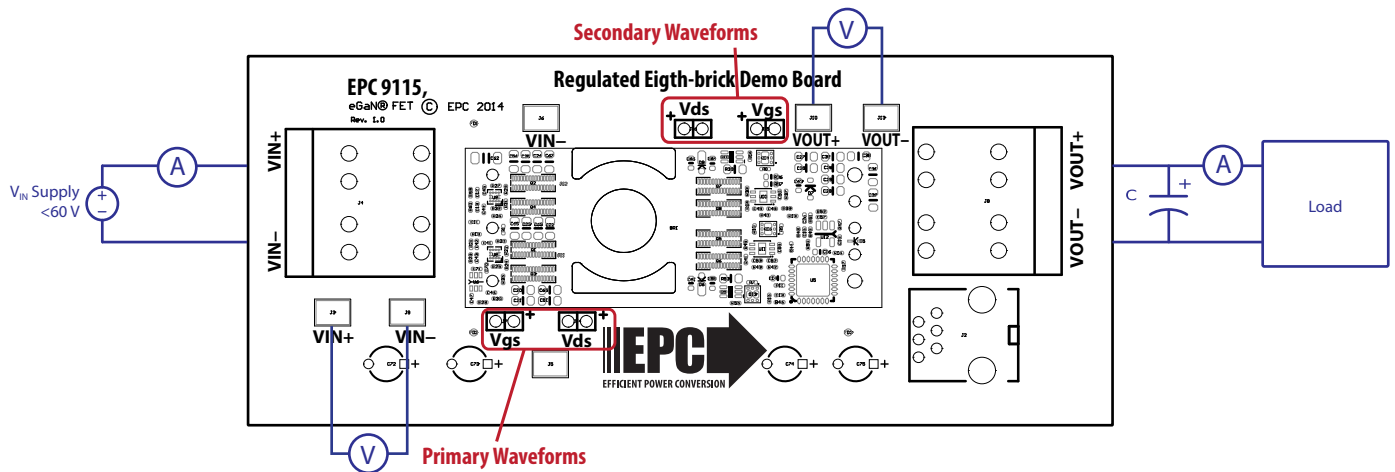

Figure 2: Proper Connection and Measurement Setup

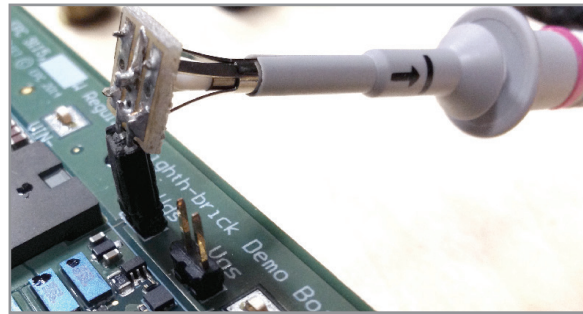
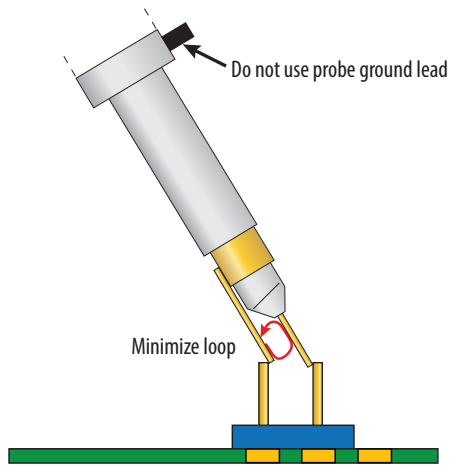

Figure 3: Proper Measurement of Switch Nodes or Output Voltage

CIRCUIT PERFORMANCE

The EPC9115 demonstration circuit was designed to showcase the size and performance that can readily be achieved using eGaN FETs. The 300 kHz operating frequency is 50% - 100% higher than typical commercial eighth-brick converters.

Figure 4 shows typical full-load waveforms for a 52 V input voltage using probe tip adapters as shown in Figure 3. Figure 5 shows efficiency plots for several input voltages at 400 LFM (2 m/s) airflow at 25 °C. Data are taken after converter reaches thermal steady state.

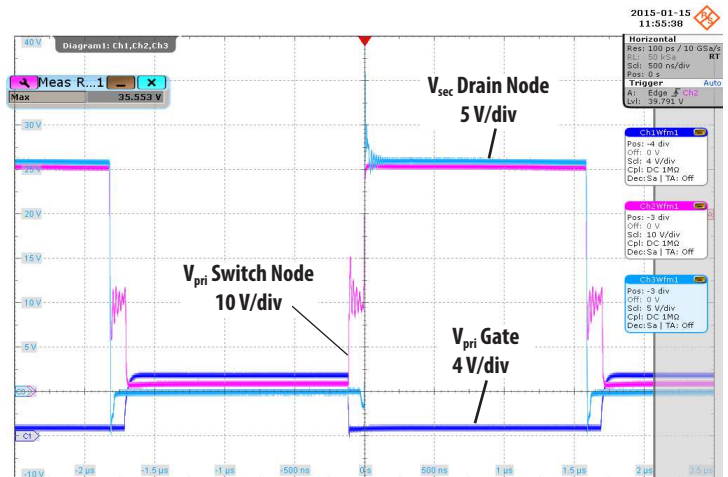

Figure 4: Typical waveforms taken at 52 V_{IN} to 12 V_{OUT}/42 A_{OUT}

OPERATING CONSIDERATIONS

The EPC9115 is a demonstration platform intended to show the capabilities of eGaN FETs in an eighth-brick application. The converter has basic regulation and overcurrent protection, but the complete feature set often found with 1/8th-brick converters is not implemented. In particular, the EPC9115 does not have overvoltage, over-temperature, or fast-acting short-circuit protection. Hence, the circuit is recommended for power stage and efficiency evaluation purposes. The transient response has not been optimized.

SOURCE and LOAD: It is recommended that the converter be driven from a source with both low ac and dc impedance. Additional input capacitance may be added as necessary. Additional output capacitance may be added to the output in the form of electrolytic capacitors, up to 1000 μ F. Addition of bulk capacitance in the form of low ESR capacitors is not recommended.

THERMAL MANAGEMENT: The EPC9115 demo board has no on-board thermal protection. Thermal images for steady state full load operation are shown in Figure 6. The EPC9115 is intended for bench evaluation with nominal room ambient temperature and forced air cooling. Operation without forced air cooling is possible for limited power operation. It is recommended that the maximum temperature on the EPC9115 not exceed 125 $^{\circ}$ C.

ELECTRICAL PROTECTION: Overcurrent protection is set at a nominal value of 50 A at room temperature. Current sensing is implemented using inductor DCR sensing, and as a result exhibits variability as a function of the inductor and its temperature. As the inductor becomes hotter, the trip point becomes lower.

The EPC9115 demo board does not have any input overvoltage protection on board. It is also recommended to make sure that the converter is started with an output voltage of 1V or less.

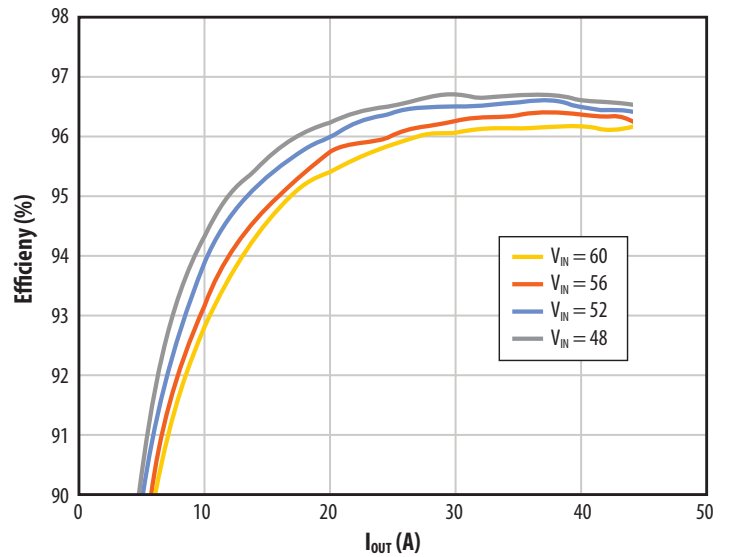

Figure 5: Typical efficiency curves. Operating conditions: 400 LFM (2 m/s) forced convection, ambient temperature 27 $^{\circ}$ C, thermal steady state. The converter is running unregulated for the 48 V case.

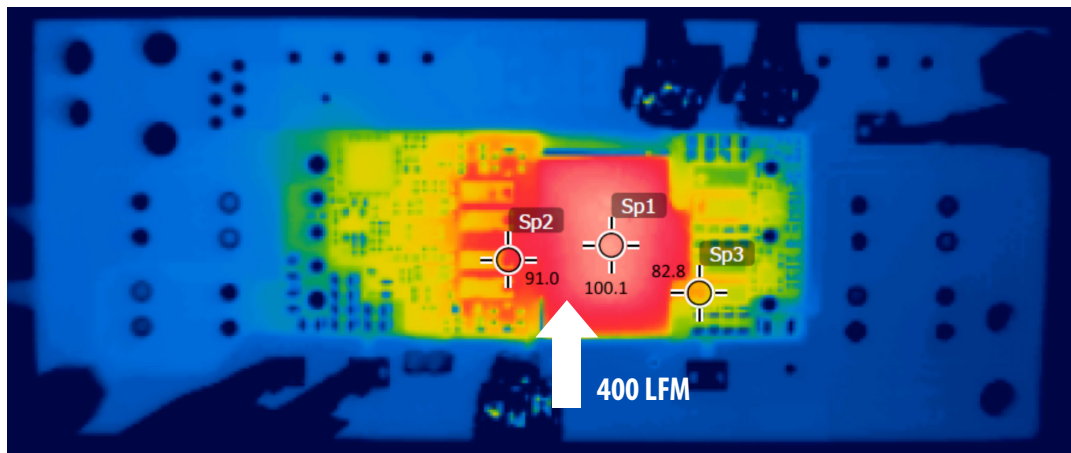

Figure 6: Thermal images of EPC9115. Operating conditions: 400 LFM (2 m/s) forced convection, ambient temperature 27 $^{\circ}$ C, thermal steady state.

Table 2: Bill of Materials

Designator	Description	Quantity	Value	MFG	MFGPN
C1, C2, C3, C4, C10, C11	Capacitor, 2.2 µF, 6.3 V, X5R	6	2.2 µF	TDK Corporation	C1005X5R0J225M050BC
C12, C13, C17, C42, C43, C46, C47, C50, C55, C58	Capacitor, 22 pF, 50 V, NPO, 5%	10	22 pF	Murata	GRM1555C1H220JA01D
C14, C16	Capacitor, 4.7 µF, 6.3 V, X7S	2	4.7 µF	TDK	C1608X7S0J475K080AC
C18	Capacitor, 1000 pF, 50 V, NPO, 5%	1	1000 pF	Murata	GRM1555C1H102JA01D
C19	Capacitor, 0.1 µF, 50 V, X7R	1	100 nF, 50 V	TDK	C1005X7R1H104K050BB
C20, C21, C22, C23, C24, C25, C51, C54, C65, C67, C68, C69	Capacitor, 1 µF, 100 V, X7S	12	1 µF, 100 V	TDK	C2012X7S2A105M125AE
C26	Capacitor, 0.047 µF, 25 V, X7R, 5%	1	0.047 µF, 25 V	Murata	GRM155R71E473JA88D
C27, C28, C29, C30, C31, C32, C33, C34, C35, C36, C37, C38	Capacitor, 4.7 µF, 25 V, X7R	12	4.7 µF, 25 V	TDK	CGA4J1X7R1E475K125AC
C39	Capacitor, 3300 pF, 2000 V, X7R	1	3300 pF	Johanson	202S43W332KV4E
C40, C41, C44, C45, C48, C49, C52, C53, C70, C71	Capacitor	10	0.22 µF	Murata	GRM155R71C224KA12D
C5, C59, C61, C64, C66	Capacitor	4	0.1 µF, 100 V	Murata	GRM188R72A104KA35D
C6, C9	Capacitor, 3.3 µF, 16 V, X5R	2	3.3 U	TDK Corporation	C1608X5R1C335K
C60, C62	Capacitor	2	2.2 U	Samsung	CL31B225KCHSNNE
C63	Capacitor	1	470 nF, 50 V	TDK	CGA4J3X7R1H474K125AB
C7	Capacitor, 330 pF, 25 V, NPO, 5%	1	330 pF	Murata	GRM1555C1E331JA01D
C8	Capacitor, 0.1 µF, 16 V, X7R	1	0.1 µF	Murata	GRM155R71C104KA88D
D1, D2, D3	Schottky diode	3	BAT41K	ST Microelectronics	BAT41KFILM
D6, D9	Schottky 60 V 1A	2	60 V, 1 A	Vishay	MSS1P6-M3/89A
D7	Zener Diode	1	33 V, 10 mA	NXP	BZX384-C33,115
J2	Programming connector	1	N/A	TE Connectivity	5520425-3
J3, J5, J6, J9, J10, J13	Test point	6	N/A	Keystone	5015
J4, J8	Power connector	2	N/A	Molex	399100102
J7, J14, J15, J16	Connector	4	N/A	Tyco	4-103185-0-02
L1	Inductor	1	180 Ω	TDK	MPZ1608S181ATAH0
L2	Inductor	1	0.33 µF, 20 A	Abracon	ASPI-7318-R33M-T
L3	470 nH, 62A inductor	1	470 nH	Vishay	IHLP-6767GZ-01
Q1, Q2, Q3, Q4	eGaN FET, 80 V, 60 A, 2.5 mΩ	4		EPC	EPC2021
Q13, Q14	NPN/PNP DFN PBSS4160PANP	2		NXP	PBSS4160PANP,115
Q16	DUAL NPN DFN PBSS4160PAN	1		NXP	PBSS4160PAN,115
Q5, Q6, Q7, Q8	eGaN FET, 60 V, 60 A, 2 mΩ	4		EPC	EPC2020
Q9, Q10	P-Channel DMOS FET, -60 V, 1.6 A, logic level gate	2		Vishay	SQ1421EEH-T1-GE3
R1, R19, R26, R33, R40, R42, R43	Resistor	7	1R0	Yageo	RC0402FR-071RL
R12, R13	Resistor, 1%	2	470	Vishay	CRCW0402470RFKED
R14	Resistor, 0.1%	1	4.99 K, 0.1%	Susumu	RG1608P-4991-B-T5
R15, R46, R48, R51	Resistor, 0.1%	4	1 K, 0.1%	Susumu	RG1005P-102-B-T5
R2	Resistor	1	100 K	Vishay	CRCW0603100KFKEA
R20, R24, R27, R31, R34, R38, R41, R45	Resistor	8	4.7	Yageo	RC0402FR-074R7L
R21, R23, R28, R30, R37, R44, R59, R60	Resistor	8	49.9	Yageo	RC0402FR-0749R9L
R22, R25, R29, R32	Resistor	4	ZERO	Vishay	CRCW04020000Z0ED
R3, R4	Resistor	2	33.2 K	Vishay	RC0402FR-0733K2L

Table 2: Bill of Materials

Designator	Description	Quantity	Value	MFG	MFGPN
R36, R57	Resistor	2	1	Vishay	CRCW08051R00FKEA
R39, R53	Resistor	2	2	Vishay	CRCW08052R00FKEA
R47	Resistor	1	249	Yageo	RC0402FR-07249RL
R49	Resistor, 0.1%	1	20 K, 0.1%	Susumu	RG1005P-203-B-T5
R5, R11, R16, R17	Resistor	4	10 K	Vishay	CRCW040210K0FKED
R50	Resistor, 0.1%	1	4.99 K, 0.1%	Susumu	RG1005P-4991-B-T5
R55, R56	Resistor	2	2.2	Yageo	RC0402FR-072R2L
R6, R18	Resistor	2	15 K	Yageo	RC0402FR-0715KL
R7, R8	Resistor	2	4.75 K	Yageo	RC0402FR-074K75L
R9, R10	Resistor	2	1.8 K	Yageo	RC0402FR-071K8L
T1	Bias transformer	1		Custom Coils	CCI-7082
U1	3.3 V linear regulator	1	3.3 V	Microchip	MCP1700T3302EMBCT-ND
U10, U11	eGaN Gate Driver with LDO	2		TI	UCC27611DRVT
U12	Rail-to-Rail Input/Output, ± 15 V, Operational Amplifier	1		TI	OPA209AIDBV
U2, U4	5.0 V linear regulator	2	LP2985 5 V	TI	LP2985-50DBVR
U3	Power supply controller	1		On Semiconductor	NCP1030DMR2G
U5	dsPIC microcontroller	1		Microchip	DSPIC33FJ16GS502-E/M
U6	Dual inverter	1	NC7WZ14	Fairchild	NC7WZ14EP6X
U7	2 channel unidirectional magnetic isolator	1	IL611	NVE Corporation	IL611-1E
U8, U9	half-bridge eGaN gate driver	2	LM5113	TI	LM5113TME/NOPB
CORE1	Planer E core	1		Ferroxcube	EQ20/R-3F35
CORE2	Planer I core	1		Ferroxcube	PLT20/S-3F35

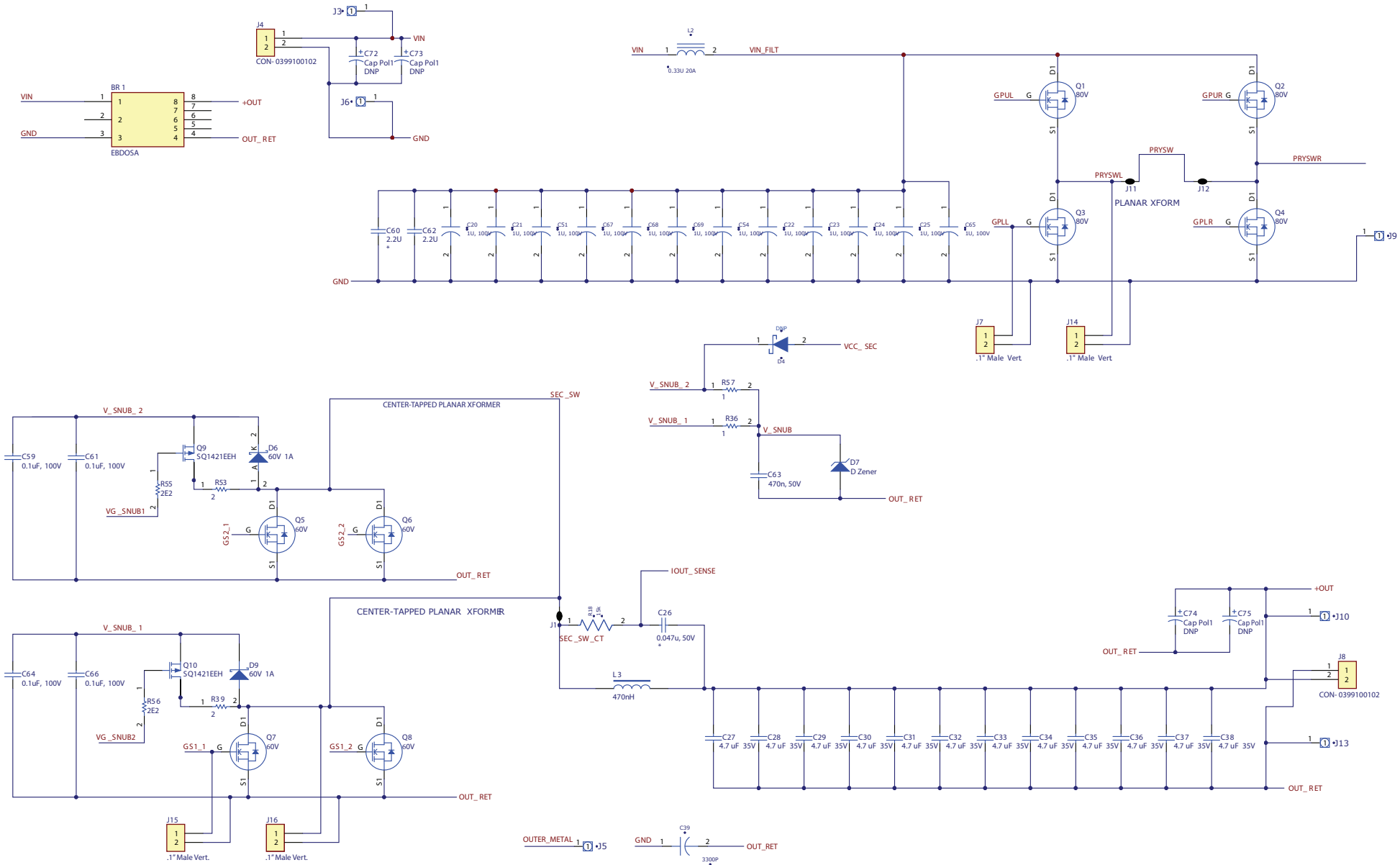

Figure 7: EPC9115 Demonstration board schematic - Power

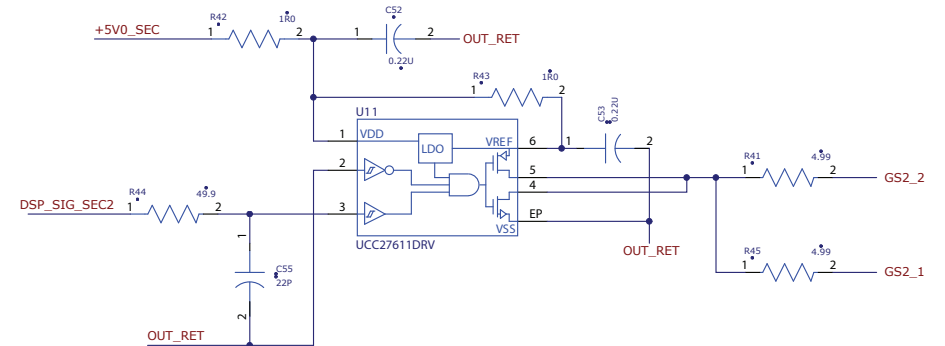
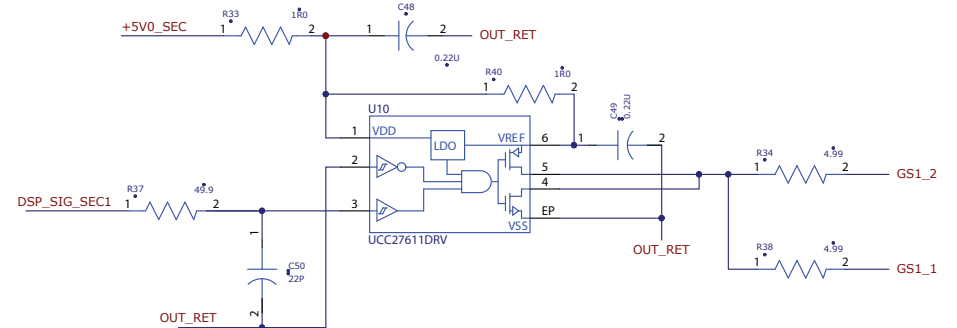
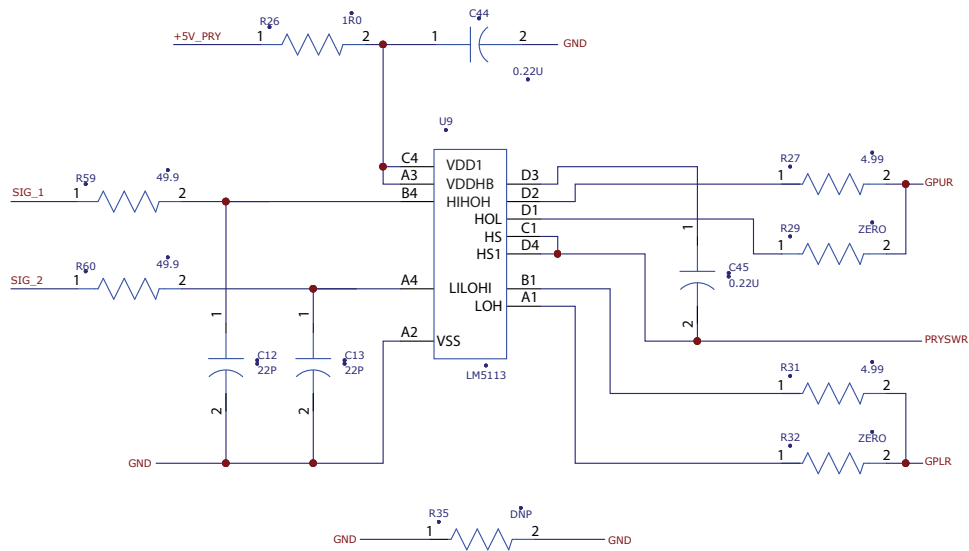
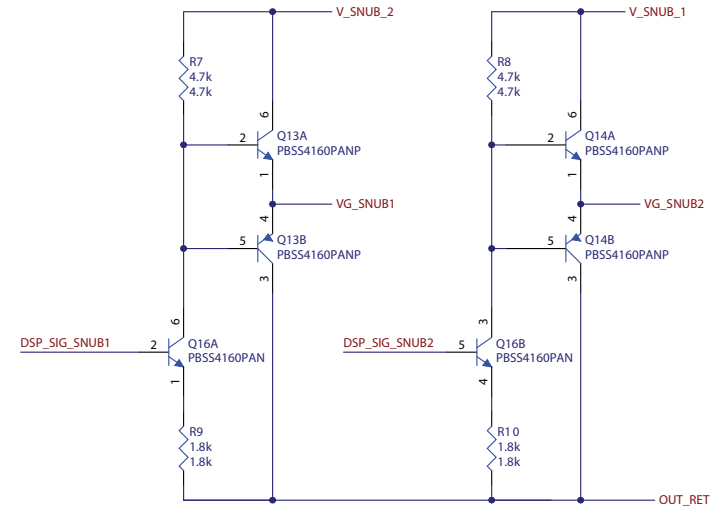
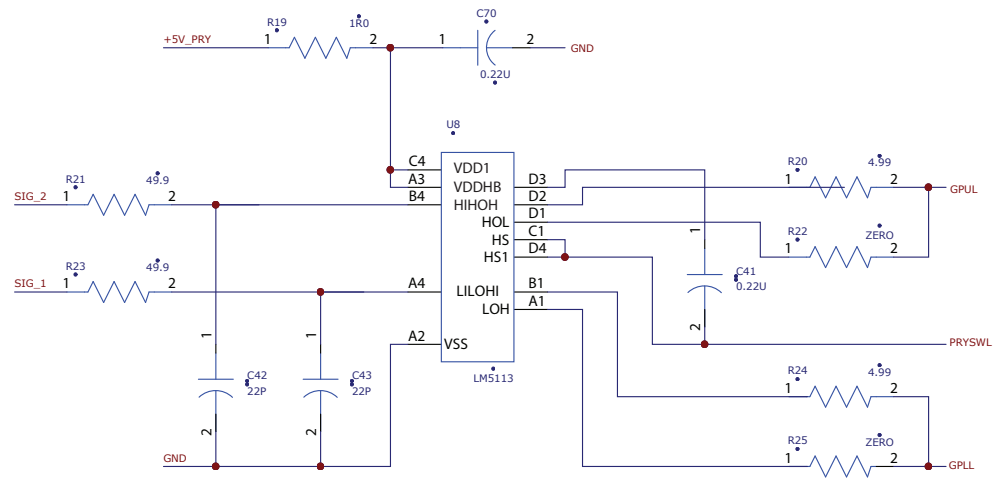

Figure 8: EPC9115 Demonstration board schematic – Gate Drive

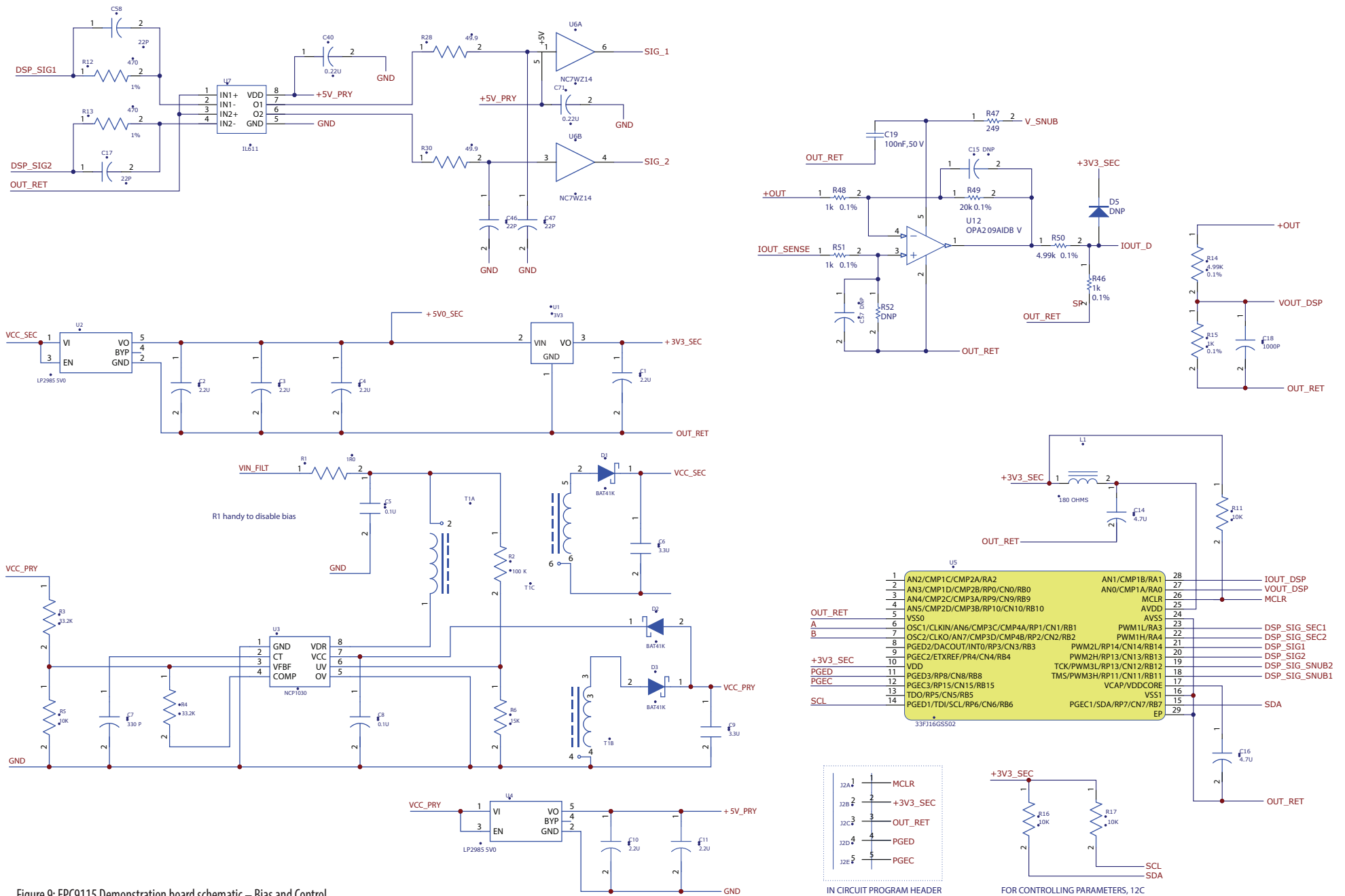

Figure 9: EPC9115 Demonstration board schematic – Bias and Control