



Chipsmall Limited consists of a professional team with an average of over 10 year of expertise in the distribution of electronic components. Based in Hongkong, we have already established firm and mutual-benefit business relationships with customers from,Europe,America and south Asia,supplying obsolete and hard-to-find components to meet their specific needs.

With the principle of “Quality Parts,Customers Priority,Honest Operation,and Considerate Service”,our business mainly focus on the distribution of electronic components. Line cards we deal with include Microchip,ALPS,ROHM,Xilinx,Pulse,ON,Everlight and Freescale. Main products comprise IC,Modules,Potentiometer,IC Socket,Relay,Connector.Our parts cover such applications as commercial,industrial, and automotives areas.

We are looking forward to setting up business relationship with you and hope to provide you with the best service and solution. Let us make a better world for our industry!



Contact us

Tel: +86-755-8981 8866 Fax: +86-755-8427 6832

Email & Skype: info@chipsmall.com Web: www.chipsmall.com

Address: A1208, Overseas Decoration Building, #122 Zhenhua RD., Futian, Shenzhen, China



Development Board EPC9121 Rev. 1.0 Quick Start Guide

EPC2107

10 W Multi-Mode Wireless Power System

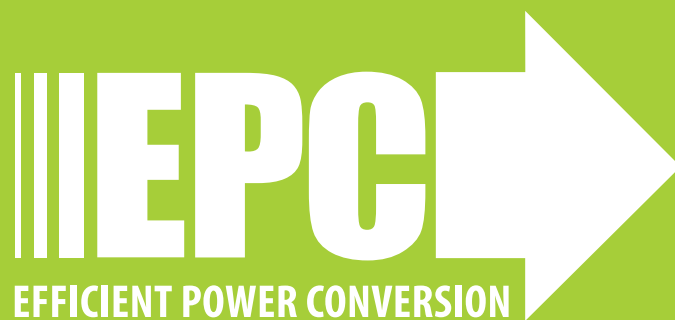

DESCRIPTION

The EPC9121 is a high efficiency, power demonstration system capable of operating to multiple wireless power standards. It is compatible with the Qi standard of the Wireless Power Consortium (WPC), the Power Matters Alliance (PMA) standard (now merged with AirFuel™ Alliance) and AirFuel (formerly A4WP) wireless power standards. In AirFuel resonant mode, hence referred to as AirFuel mode, the EPC9121 system operates at 6.78 MHz with the amplifier circuit configured for ZVS operation. In this mode, the system can deliver up to 10 W of power into the source coil. In Qi/PMA inductive mode, the system operates at 165 kHz with the amplifier circuit configured for hard-switching operation and can deliver up to 5 W of load power into the device. The purpose of the EPC9121 is to simplify the evaluation process of both resonant and inductive wireless power technologies using eGaN® FETs and eGaN® ICs.

The EPC9121 wireless power system comprises the four boards (shown in figures 1 and 2) namely:

1. A multi-mode capable EPC9511 source board (transmitter or power amplifier)
2. A multi-mode source coil (transmit coil) compatible with the AirFuel Class 2 standard and Qi (A6) /PMA standards
3. An AirFuel compatible Category 3 AirFuel device coil (receive coil) with rectifier and DC output
4. A Wireless Power Consortium (Qi) and Power Matters Alliance (now AirFuel) compatible device coil (receive coil) with rectifier and DC output

The amplifier board features various enhancement-mode GaN devices which are:

- The 100 V rated EPC2107 half-bridge eGaN® IC with integrated synchronous bootstrap FET used in the main wireless power amplifier.
- The 100 V rated EPC2036 eGaN FET used in the ZVS disconnect switch circuit and the main device of the SEPIC converter pre-regulator.
- The 100 V rated EPC2038 eGaN FET used in the controller circuit for changing set points based on operating mode.

The amplifier is configured for single ended operation and includes the gate driver(s), oscillators, and feedback controller for the pre-regulator, which ensures operation for wireless power control based on the AirFuel standard. This configuration allows for testing compliant to the AirFuel Class 2 standard over a load range as high as $\pm 35j \Omega$. The pre-regulator features the 100 V rated 65 m Ω EPC2036 as the main switching device for a SEPIC converter.

The amplifier is equipped with a pre-regulator controller that adjusts the voltage supplied to the class D amplifier based on the limits of three parameters: coil current magnitude, DC power delivered to the amplifier, and maximum amplifier supply voltage. The controller ensures that all the three parameters operate within their respective limits. Changes in the device load power demand, physical placement of the device on the source coil and other factors such as metal objects in proximity to the source coil all contribute to variations in coil

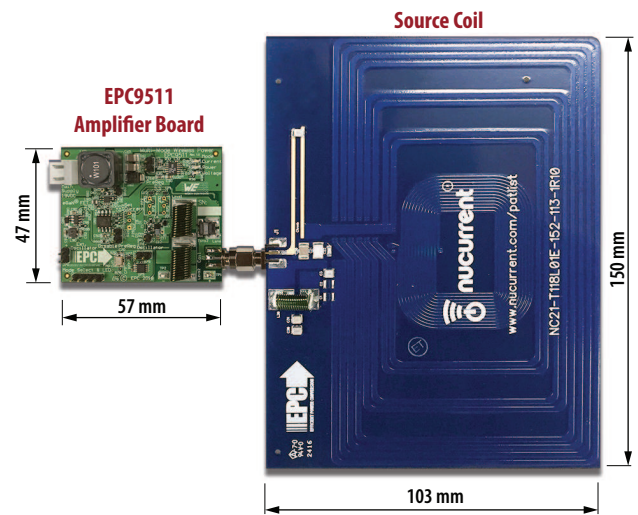

Figure 1: EPC9121 wireless power demonstration system

current, DC power, and amplifier voltage requirements. Based on load conditions, the controller will ensure the correct operating conditions for the class D amplifier based on the AirFuel standard. Operation in the Qi/PMA mode follows the same procedure where only the voltage, power, and current levels are adjusted accordingly. While this does not fully follow the Qi standard, it allows the EPC9121 to demonstrate the capabilities of eGaN FETs and ICs in a multi-mode system. Enhanced micro-controller based control systems can allow the system to operate and be compliant to either standard.

The pre-regulator can be bypassed to allow testing with custom control hardware. The board further allows easy access to critical measurement nodes facilitating accurate power measurement instrumentation hookup. A simplified diagram of the amplifier board is given in figure 3.

The source coil is specifically designed to be compatible with all the wireless standards and can be driven by a single source. The passive tuning circuits allow for operation at either high or low frequency with minimal degradation to power delivery capability. The AirFuel portion of the source coil is compatible with the AirFuel Class 2 standard and has been pre-tuned to operate at 6.78 MHz. The Qi/PMA portion of the source coil is compatible with the A6 Qi standard and is designed to operate at 165 kHz.

The EPC9121 is provided with two receive device units: The first is tuned to and compatible with the AirFuel Category 3 specification and the second is an inductive mode unit compatible with the 5 W Qi receiver standard. Each of the device units includes a high frequency schottky diode based full bridge rectifier and output filter to deliver a filtered unregulated DC voltage. The device board comes equipped with two LED's, one green to indicate the power is being received with an output voltage equal or greater than 4 V and a second red LED that indicates an overvoltage condition where the output voltage exceeds 36 V.

For more information on the EPC2107, EPC2036, and EC2038 eGaN FETs please refer to the respective datasheet available from EPC at www.epc-co.com. The datasheet should be read in conjunction with this quick start guide.

Table 1: Performance Summary (T_A = 25°C) EPC9511 Rev. 1.0

Symbol	Parameter	Conditions	Min	Max	Units
V _{IN}	Main Input Voltage Range – Pre-Regulator Mode	Also Used in Bypass Mode for Logic Supply	17	24	V
V _{IN}	Amplifier Input Voltage Range	Bypass Mode	0	80	V
V _{IN_UVLO+}	V _{IN} Rising Threshold	Regulated Mode Only		18.3	V
V _{IN_UVLO-}	V _{IN} Falling Threshold	Regulated Mode Only	17.3		V
V _{AMP}	Amplifier Supply Voltage	Regulated AirFuel Mode Regulated Qi/PMA Mode		66 26	V
I _{OUT}	Switch Node Output Current			1.7*	A
V _{extosc}	External Oscillator Input Threshold	Input 'Low' Input 'High'	-0.3 2.4	0.8 5	V
V _{Pre_Disable}	Pre-regulator Disable Voltage Range	Floating	-0.3	5.5	V
I _{Pre_Disable}	Pre-regulator Disable Current	Floating	-10	10	mA
V _{Ext_Osc}	External Oscillator Voltage Range	Open Drain/ Collector	-0.3	5	V
I _{Ext_Osc}	External Oscillator Current Range	Open Drain/ Collector	-25	25	mA
V _{Mode_Src}	Mode Select Source Voltage		4.5	5.5	V
I _{Mode_Src}	Mode Select Source Current			30	mA
V _{Mode_Sel}	Mode Select Input Voltage	AirFuel and Qi/PMA modes	-0.3	5.1	V
I _{Mode_Sel}	Mode Select Input Current	AirFuel and Qi/PMA modes	-50	30	mA
V _{Mode_Ret}	Mode Select Return Voltage		-2.5	2.5	V
I _{Mode_Ret}	Mode Select Return Current		-25	25	mA

* Maximum current depends on die temperature – actual maximum current will be subject to switching frequency, bus voltage and thermals.

Table 2: Performance Summary (T_A = 25 °C) AirFuel and Qi/PMA compatible Device Board

Symbol	Parameter	Conditions	Min	Max	Units
V _{OUT}	Output Voltage Range		0	38	V
I _{OUT}	Output Current Range		0	1.5 [†]	A

[†] Actual maximum current subject to operating temperature limits

The Source coil used in this wireless power transfer demonstration system is provided by NuCurrent (nucurrent.com). Reverse engineering of the source coil is prohibited and protected by multiple US and international patents. For additional information on the source coil, please contact NuCurrent directly or EPC for contact information.

MECHANICAL ASSEMBLY

The assembly of the EPC9121 wireless power transfer demonstration kit is simple and shown in figure 1. The source coil and amplifier have been equipped with SMA connectors. The source coil is simply connected to the amplifier.

The device board does not need to be mechanically attached to the source coil. It is strongly recommended to place a 5 mm thick sheet of Plexiglas on top of the source coil to provide an insulating barrier for the devices. This will also ensure that the devices are placed at the correct specified distance above the source coil for optimal performance to all the operating standards. This barrier also protects the user touching exposed electrical nodes and static discharge which can destroy the amplifier board.

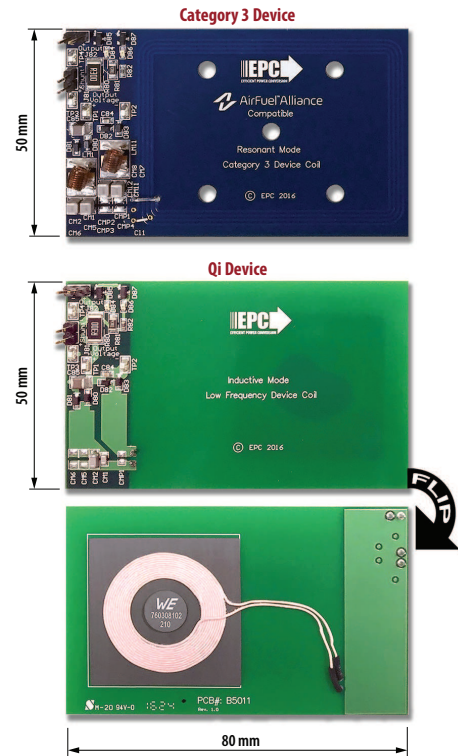

Figure 2: Device boards AirFuel compatible (top), Qi/PMA compatible (bottom).

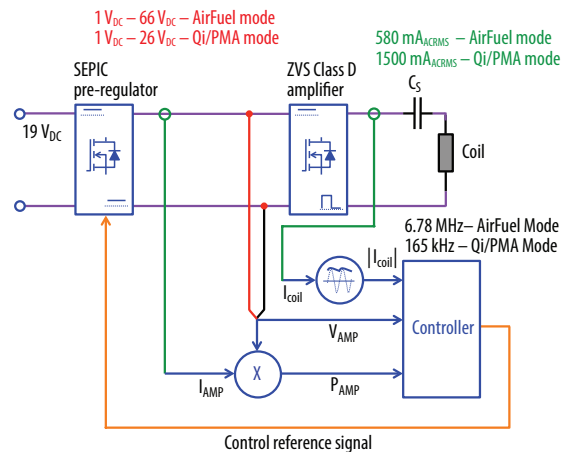

Figure 3: Block diagram of EPC9511 multi-mode capable wireless power amplifier controller.

DETAILED DESCRIPTION

The Amplifier Board (EPC9511)

Figure 3 shows the control system block diagram of the EPC9511 ZVS class D amplifier with pre-regulator and figure 4 shows the power schematic. The pre-regulator is used to control the ZVS class D wireless power amplifier based on three feedback parameters:

1. The magnitude of the coil current indicated by the green LED,
2. The DC power drawn by the amplifier indicated by the yellow LED and,
3. A maximum supply voltage to the amplifier indicated by the red LED.

Only one parameter at any time is used to control the pre-regulator with the highest priority being the maximum voltage supplied to the amplifier followed by the power delivered to the amplifier and lastly the magnitude of the coil current. The maximum amplifier supply voltage is pre-set to 66 V in AirFuel mode and 26 V in Qi/PMA mode and the maximum power drawn by the amplifier is pre-set to 10 W in either mode. The coil current magnitude is pre-set to 580 mA_{RMS} in AirFuel mode and 1500 mA_{RMS} in Qi/PMA mode, but can be made adjustable using P25. The pre-regulator comprises a SEPIC converter that can operate at full power with an input supply voltage from 17 V through 24 V.

The pre-regulator can be bypassed by connecting the positive supply directly to the ZVS class D amplifier supply after removing the jumper at location JP1 and connecting the main positive supply to the bottom pin. JP1 can also be removed and replaced with a DC ammeter to directly measure the current drawn by the amplifier. When doing this, the operator must provide a low impedance connection to ensure continued stable operation of the controller. Together with the Kelvin voltage probes (TP1 and TP2) connected to the amplifier supply, an accurate measurement of the power drawn by the amplifier can be made.

The EPC9511 is also provided with a miniature high efficiency switch-mode 5 V supply to power the logic circuits on board such as the gate drivers and oscillator allowing the EPC9511 board to operate from a single source.

The amplifier comes with two of its own low supply current oscillators. This first oscillator is pre-programmed to 6.78 MHz ± 678 Hz and the second to 165 kHz. The oscillator signal can be disconnected by removing jumper JP71 and can then be sourced from an external oscillator when connected to J70. J70 can also serve as an oscillator reference output when using the internal oscillators.

The pre-regulator can be disabled by inserting a jumper into JP50. However, note that this connection is floating with respect to the ground so removing the jumper for external connection requires a floating switch to correctly control this function. Refer to the datasheet of the controller IC and the schematic in this QSG for specific details.

The EPC9511 is provided with 3 LED's that indicate the mode of operation of the system. If the system is operating in coil current limit mode, then the green LED will illuminate. For power limit mode, the yellow LED will illuminate. Finally, when the pre-regulator reaches maximum output voltage the red LED will illuminate indicating that the system can no longer regulate either the coil current or delivered power. This can occur when the magnitude of the load impedance is too high in AirFuel mode or if the device unit draws insufficient current in the inductive (Qi) mode.

The EPC9511 amplifier is also equipped with Under Voltage Lockout (UVLO) protection which prevents the amplifier from starting up with insufficient voltage on the main supply. This feature is only operational in the regulated mode and does not affect operation in bypass mode. In addition, the EPC9511 has protection against reverse polarity connection of the main supply that is capable of conducting as much as 11 A_{DC} for a short period.

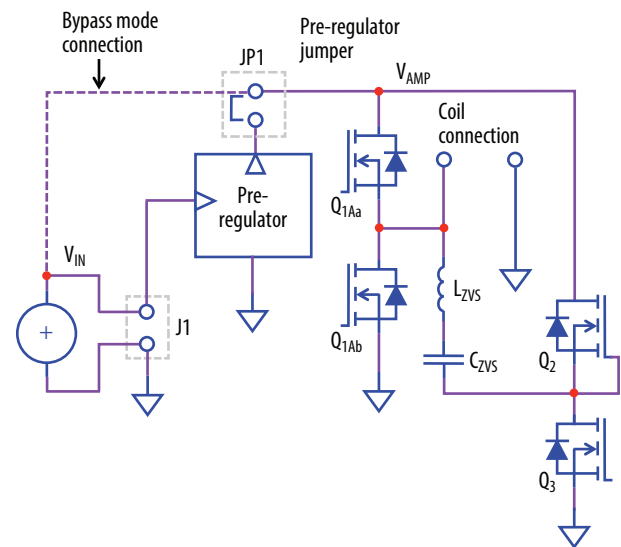

Figure 4: Power circuit schematic of EPC9511 amplifier.

ZVS Timing Adjustment (AirFuel Mode ONLY)

Setting the correct time to establish ZVS transitions is critical to achieving high efficiency with the EPC9511 amplifier when operating at high frequency. This can be done by selecting the values for R71 and R72 or P71 and P72 respectively. This procedure is best performed using a potentiometer installed at the appropriate locations (P71 and P72) that is used to determine the fixed resistor values. The timing MUST initially be set WITHOUT the source coil connected to the amplifier. The timing diagrams are given in figure 12 and should be referenced when following this procedure. Only perform these steps if changes have been made to the board as it is shipped preset. The steps are:

1. With power off, remove the jumper in JP1 and install it into JP50 to place the EPC9511 amplifier into Bypass mode. Connect the main input power supply (+) to JP1 (bottom pin – for bypass mode) with ground connected to J1 ground (-) connection.
2. With power off, connect the control input power supply bus (19 V) to Vin+ connector (J1). Note the polarity of the supply connector.
3. Connect a LOW capacitance oscilloscope probe to the probe-hole of the half-bridge to be set and lean against the ground post as shown in figure 8.
4. Turn on the control supply after ensuring that the supply is approximately 19 V with a 2 A current limit.
5. Turn on the main supply voltage to the required predominant operating value (such as 24 V but NEVER exceed the absolute maximum voltage of 80 V).
6. While observing the oscilloscope, adjust the applicable potentiometers to achieve the green waveform of figure 12.
7. Replace the potentiometers with fixed value resistors if required. Remove the jumper from JP50 and install it back into JP1 to revert the EPC9511 back to pre-regulator mode.

Determining component values for L_{ZVS} (AirFuel Mode ONLY)

The ZVS tank circuit is not operated at resonance, and only provides the necessary negative device current for self-commutation of the output voltage at turn off. The capacitor C_{ZVS1} is chosen to have a very small ripple voltage component and is typically around 1 μ F. The amplifier supply voltage and switch-node transition time will determine the value of inductance for $L_{ZVS} = L_{ZVS1} + L_{ZVS2}$ which needs to be sufficient to maintain ZVS operation over the DC device load resistance range and coupling between the device and source coil range. The value of the inductance can be calculated using the following equation:

$$L_{ZVS} = \frac{\Delta t_{vt}}{8 \cdot f_{sw} \cdot (C_{OSSQ} + C_{well})} \tag{1}$$

Where:

- Δt_{vt} = Voltage transition time [s]
- f_{sw} = Operating frequency [Hz]
- C_{OSSQ} = Charge equivalent device output capacitance [F].
- C_{well} = Gate driver well capacitance [F]. Use 20 pF for the LM5113

NOTE. the amplifier supply voltage V_{AMP} is absent from the equation as it is accounted for by the voltage transition time. The C_{OSS} of the EPC2107 eGaN FETs is very low and lower than the gate driver well capacitance C_{well} which as a result must be now be included in the ZVS timing calculation. The charge equivalent capacitance can be determined using the following equation:

$$C_{OSSQ} = \frac{1}{V_{AMP}} \cdot \int_0^{V_{AMP}} C_{OSS(v)} \cdot dv \tag{2}$$

To add additional immunity margin for shifts in coil impedance, the value of L_{ZVS} can be decreased to increase the current at turn off of the devices (which will increase device losses). Typical voltage transition times range from 2 ns through 12 ns.

The Multi-mode capable source coil

Figure 16 shows the schematic for the source coil which is both AirFuel Class 2 and Qi A6 compatible. The tuning network is designed to decouple the two coils from each other based on operating frequency. In AirFuel mode, the resonant tank circuit yields a high impedance to the Qi/PMA coil thus preventing current from flowing and influencing the generated field. In Qi/PMA mode, the small value of the high frequency coil tuning capacitance yields sufficient impedance at the low frequency to decouple the AirFuel coil thus preventing current from flowing and influencing the generated field. The AirFuel mode series tuning network is differential to allow a balanced connection and voltage reduction for the capacitors. The tuning network for the Qi coil is in accordance with the A6 Qi standard.

The AirFuel compatible device board

Figure 17 shows the schematic for the Category-3 AirFuel compatible device board. The tuning network includes both series and shunt branches. The tuning network series tuning is differential to allow balanced connection and voltage reduction for the capacitors. The device board comes equipped with a Kelvin connected output DC voltage measurement terminal and a built in shunt to measure the output DC current. Two LEDs have been provided to indicate that the board is receiving power with an output voltage greater than 4 V (green LED) and that the board output voltage limit has been reached (greater than 36 V using the red LED).

The Qi/PMA compatible device board

Figure 18 shows the schematic for the Qi/PMA compatible device board. The tuning network includes both series and shunt branches in accordance with the Qi standard. The device board comes equipped with a Kelvin connected output DC voltage measurement terminal and a built in shunt to measure the output DC current. Two LEDs have been provided to indicate that the board is receiving power with an output voltage greater than 4 V (green LED) and that the board output voltage limit has been reached (greater than 36 V using the red LED).

QUICK START PROCEDURE

The EPC9511 amplifier board is easy to set up and evaluate the performance of the eGaN FET in a wireless power transfer application. Refer to figure 1 to assemble the system and figures 5 through 11 for proper connection and measurement setup before following the testing procedures.

The EPC9511 can be operated using any one of two alternative methods to either wireless power standard:

- a. Using the pre-regulator.
- b. Bypassing the pre-regulator.

a. Operation using the pre-regulator

The pre-regulator is used to supply power to the amplifier in this mode and will limit the coil current, power delivered or maximum supply voltage to the amplifier based on the pre-determined settings.

The main 19 V supply must be capable of delivering 2 A_{DC} . It is not necessary to turn up the voltage of this supply when instructed to power up the board, instead simply turn on the supply.

1. Make sure the entire system is fully assembled prior to making electrical connections and make sure jumper JP1 and JP71 are installed. Select AirFuel or Qi/PMA mode according to figure. 6 and 7. Also make sure the source coil is attached to the amplifier and that the device board is connected to a load.
2. With power off, connect the main input power supply bus to J1 as shown in figure 5. Note the polarity of the supply connector.

3. Make sure all instrumentation is connected to the system.
4. Turn on the main supply voltage (19 V). It is not necessary start at 0 V. Instead, preset the voltage to 19 V and then power up.
5. Once operation has been confirmed, observe the output voltage, efficiency and other parameters on both the amplifier and device boards.
6. For shutdown, please follow the above five steps in the reverse order.

b. Operation bypassing the pre-regulator

In this mode, the pre-regulator is bypassed and the main power is connected directly to the amplifier. This allows the amplifier to be operated using an external regulator. NOTE: In this mode there is no protection for ensuring the correct operating conditions for the eGaN devices.

1. Make sure the entire system is fully assembled prior to making electrical connections and make sure jumper JP1 has been removed and installed in JP50 to disable the pre-regulator and place the EPC9511 in bypass mode. Also make sure the source coil is attached to the amplifier and that device board is connected to a load.
2. With power off, connect the main input power supply bus to the bottom pin of JP1 and the ground to the ground connection of J1 as shown in figure 5.
3. With power off, connect the control input power supply bus to +V_{IN} (J1). Note the polarity of the supply connector. This is used to power the gate drivers and logic circuits.
4. Make sure all instrumentation is connected to the system.
5. Turn on the control supply – make sure the supply is in the 19 V range.
6. Turn on the main supply voltage to the required value (it is recommended to start at 0 V and do not exceed the absolute maximum voltage of 80 V or the current rating of the main EPC2107 ICs).
7. Once operation has been confirmed, adjust the main supply voltage within the operating range and observe the output voltage, efficiency and other parameters on both the amplifier and device boards. Monitor the temperature of the FETs as device failures can occur if the junction temperature exceeds 150°C.
8. For shutdown, please follow the above steps in the reverse order. Start by reducing the main supply voltage to 0 V followed by steps 6 through 2.

NOTE.

1. When measuring the high frequency content switch-node (Source Coil Voltage), care must be taken to avoid long ground leads. An oscilloscope probe connection (preferred method) has been built into the board to simplify the measurement of the Source Coil Voltage (shown in Figure 8).
2. AVOID using a Lab Benchtop programmable DC load as the load for the device boards. These loads have low control bandwidth and will cause the EPC9121 system to oscillate at a low frequency and may lead to failure. It is recommended to use a fixed low inductance resistor as an initial load. Once a design matures, a post regulator, such as a Buck converter, can be used.

THERMAL CONSIDERATIONS

The EPC9121 demonstration system showcases the EPC2107, EPC2036, and EPC2038 eGaN FETs and ICs in a wireless energy transfer application. Although the electrical performance surpasses that of traditional silicon devices, their relatively smaller size does magnify the thermal management requirements. The operator must observe the temperature of the gate driver and eGaN FETs to ensure that both are operating within the thermal limits as per the datasheets.

NOTE. The EPC9121 demonstration system has limited current protection only when operating off the pre-regulator. When bypassing the pre-regulator there is no current protection on board and care must be exercised not to over-current or over-temperature the devices. Excessively wide coil coupling and load range variations can lead to increased losses in the devices.

Precautions

The EPC9121 demonstration system has no controller or enhanced protection systems and therefore should be operated with caution. Some specific precautions are:

1. Never operate the EPC9121 system with a receiving device board that is AirFuel, Qi or PMA compliant as this system does not communicate with the device to correctly setup the required operating conditions. Doing so can lead to failure of the compliant device unit. Contact EPC to obtain instructions should operating the system with a compliant device be required. Please contact EPC at info@epc-co.com should the tuning of the coils be required to be changed to suit specific conditions so that it can be correctly adjusted for use with the ZVS class-D amplifier.
2. There is no heat-sink on the devices and during experimental evaluation it is possible to present conditions to the amplifier that may cause the devices to overheat. Always check operating conditions and monitor the temperature of the EPC devices using an IR camera.
3. Never connect the EPC9511 amplifier board into your VNA in an attempt to measure the output impedance of the amplifier. Doing so will severely damage the VNA. Contact EPC should you require information on the output impedance of the amplifier.
4. It is strongly recommended to place a 5 mm thick Plexiglas spacer on top of the source coil during testing to protect the user from exposed electrical contacts and static discharge that can cause the amplifier to fail.
5. The operator should not change oscilloscope probe locations or measurements on the board while in operation. Turn off first before moving the probe to a new location. Failure to follow this recommendation can lead to board failure.
6. Never touch the coil, or any exposed conductors on the any of the coils to avoid RF burns and potential failure of the amplifier.

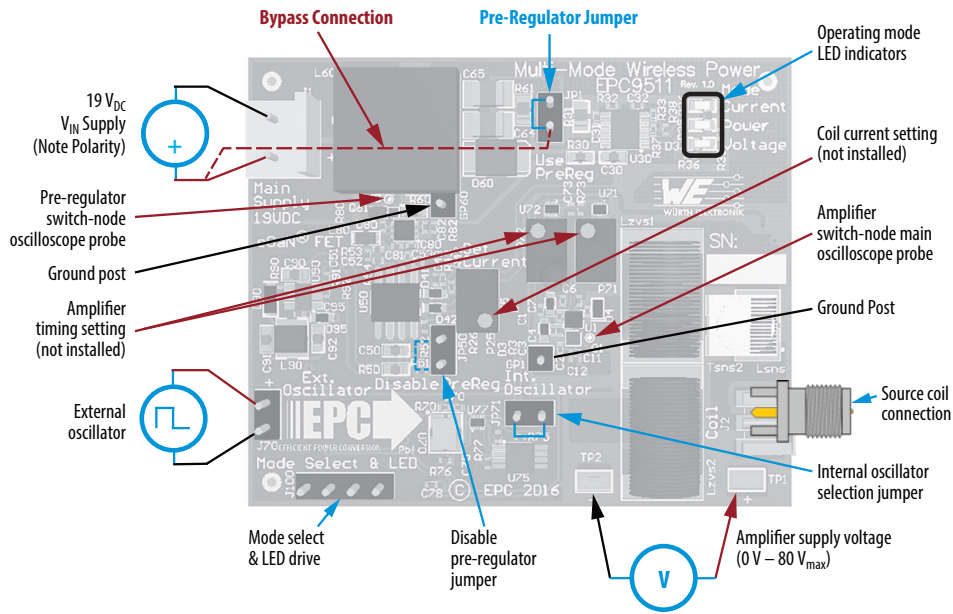

Figure 5: Proper connection and measurement setup for the EPC9511 amplifier board.

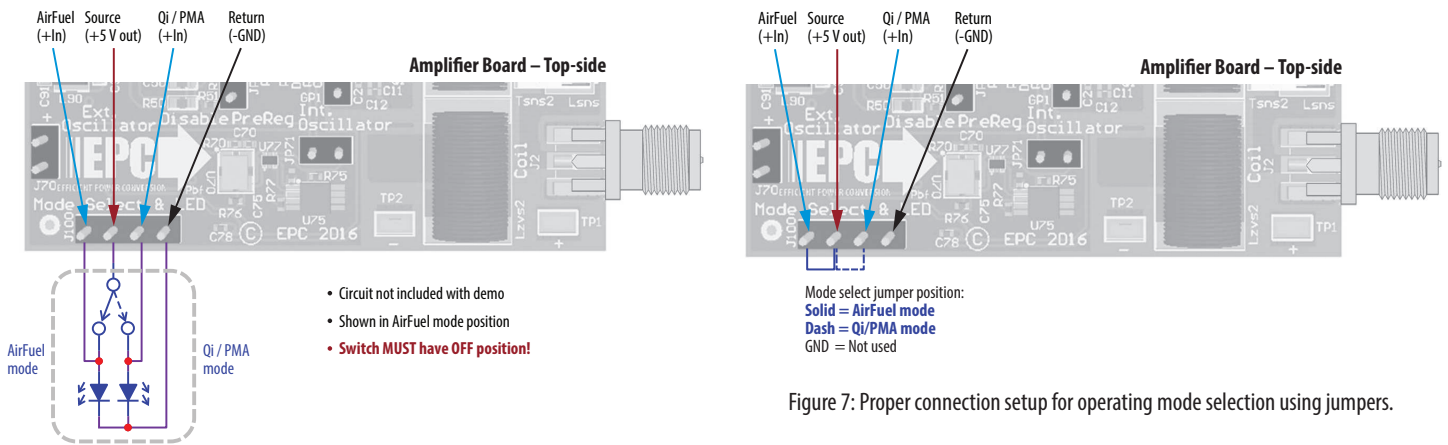

Figure 6: Proper connection setup for operating mode selection using a switch and LEDs.

Figure 7: Proper connection setup for operating mode selection using jumpers.

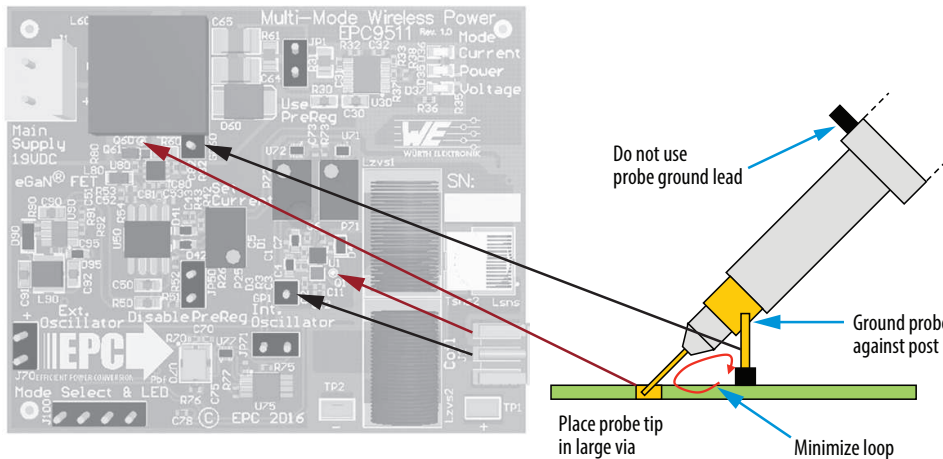

Figure 8: Proper measurement of switch Node waveforms.

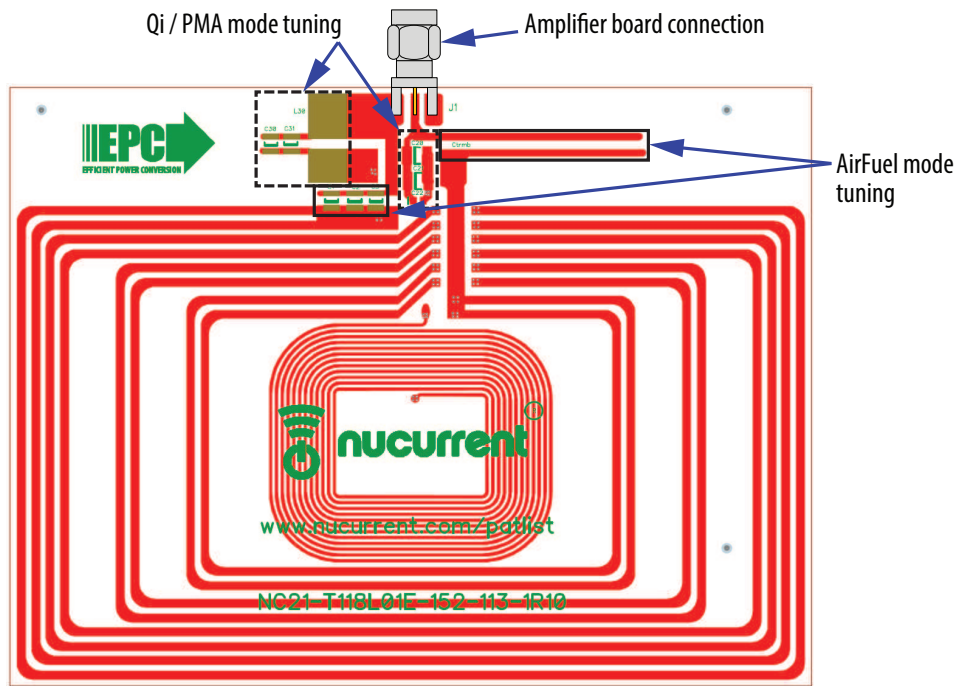

Figure 9: Source coil

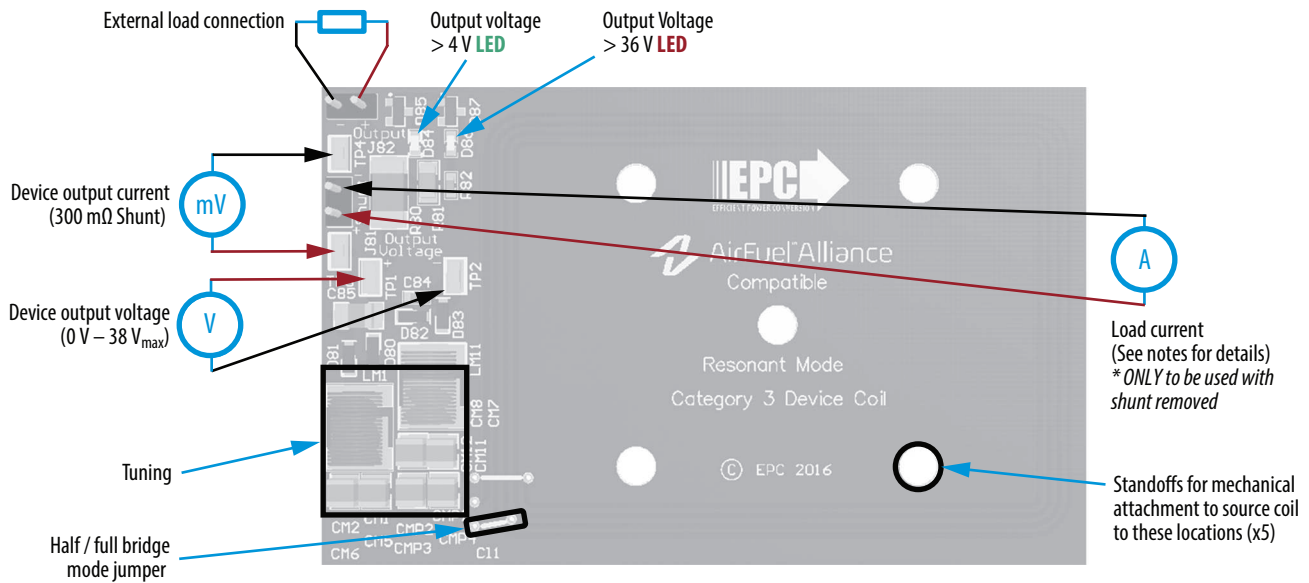

Figure 10: AirFuel compatible device coil with proper connections.
(AirFuel logo used with permission from the AirFuel Alliance)

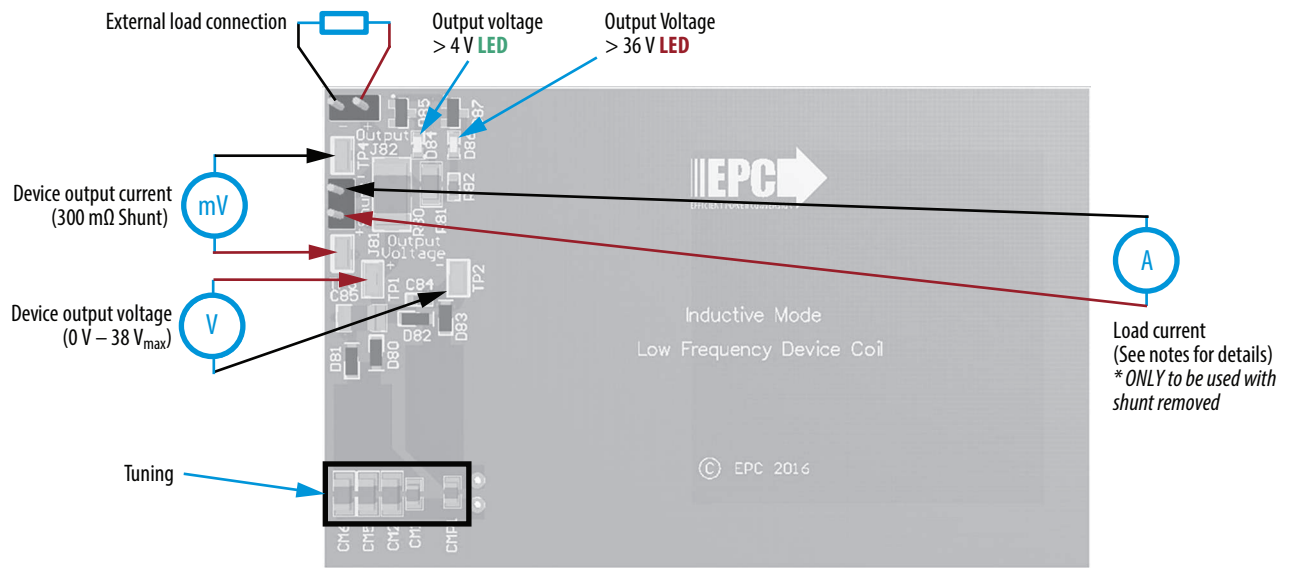

Figure 11: Qi/PMA compatible device coil with proper connections

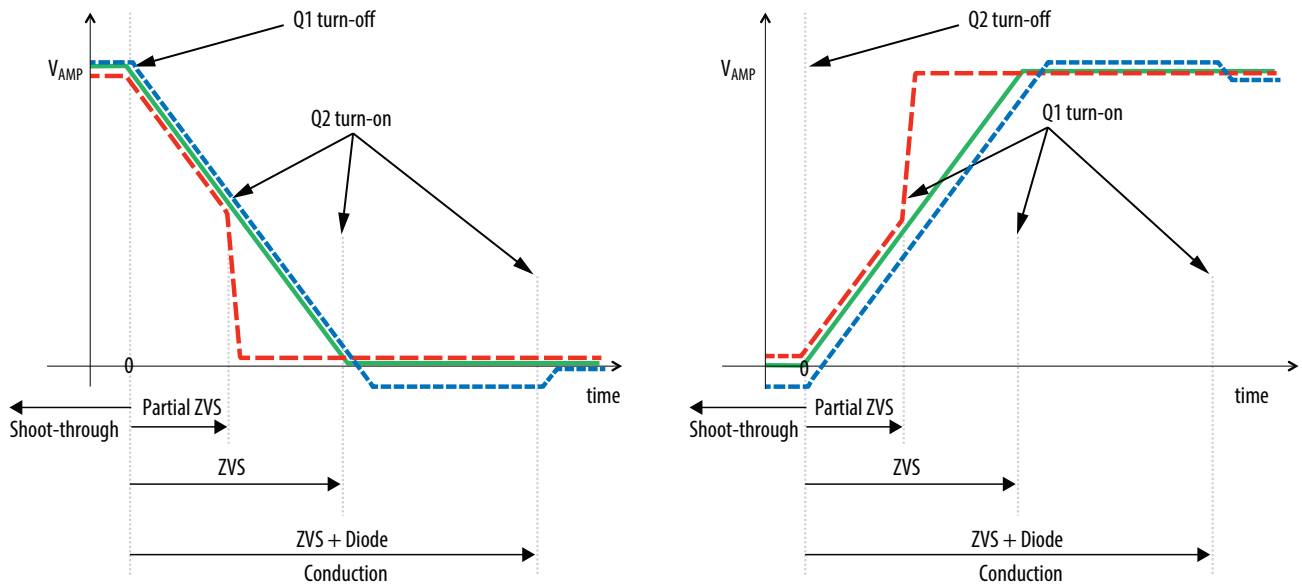

Figure 12: ZVS timing diagrams

Table 3: Bill of Materials - Amplifier Board					
Item	Qty	Reference	Part Description	Manufacturer	Part #
1	2	C1, C80	1 μ F, 10 V	Würth	885012105012
2	2	C11, C12	10 nF, 100 V	TDK	C1005X7S2A103K050BB
3	3	C15, C64, C65	2.2 μ F 100 V	Taiyo Yuden	HMK325B7225KN-T
4	16	C2, C4, C5, C51, C70, C71, C72, C75, C77, C78, C81, C100, C101, C130, C200, C210	100 nF, 25 V	Würth	885012105018
5	5	C20, C22, C46, C131, C135	1 nF, 50 V	Würth	885012205061
6	1	C21 (Only Populate with Tsns1)	680 pF, 50 V	Murata	GRM155R71H681KA01D
7	1	C45 (Not Populated)	10 nF, 100 V	Murata	C1005X7S2A103K050BB
8	1	C73 (Not Populated)	22 pF, 50 V	TDK	C1005C0G1H220J050BA
9	2	C133, C223 (Not Populated)	1 nF, 50 V	Murata	GRM1555C1H102JA01D
10	1	C220	100 nF, 16 V	Würth	885012205037
11	1	C221	1 nF, 50 V	Murata	GRM1555C1H102JA01D
12	1	C27	82 nF, 16 V	Murata	GRM155R71C823KA88D
13	2	C3, C95	22 nF, 25 V	Würth	885012205052
14	2	C30, C50	100 nF, 100 V	Murata	GRM188R72A104KA35D
15	1	C32	47 nF, 25 V	Würth	885012205054
16	2	C43, C53	10 nF, 50 V	Würth	885012205067
17	1	C52	100 pF, 50 V	Würth	885012005061
18	5	C6, C7, C31, C44, C82	22 pF, 50 V	Würth	885012005057
19	2	C61, C62	4.7 μ F, 50 V	Würth	885012209048
20	1	C63	10 μ F, 35 V	Taiyo Yuden	GMK325BJ106KN-T
21	3	C90, C91, C92	1 μ F, 25 V	Murata	GRM188R61E105KA12D
22	1	Czvs1	1 μ F, 50 V	Würth	885012207103
23	2	D1, D95	40 V, 300 mA	ST	BAT54KFILM
24	11	D2, D3, D21, D40, D41, D42, D47, D48, D49, D71, D72	40 V, 30 mA	Diodes Inc.	SDM03U40-7
25	1	D20	25 V, 11 A	Littelfuse	SMAJ22A
26	2	D203, D221	3 V9, 150mW	Bournes	CD0603-Z3V9
27	1	D35	LED 0603 Yellow	Würth	150060YS75000
28	1	D36	LED 0603 Green	Würth	150060VS75000
29	1	D37	LED 0603 Red	Würth	150060RS75000
30	3	D4, D100, D101	5 V1, 150 mW	Bournes	CD0603-Z5V1
31	1	D60	100 V, 1A	On-Semi	MBRS1100T3G
32	1	D90	40 V, 1A	Diodes Inc.	PD3S140-7
33	2	GP1, GP60	.1" Male Vert.	Würth	61300111121
34	1	J1	.156" Male Vert.	Würth	645002114822
35	1	J100	.1" Male Vert.	Würth	61300411121
36	1	J2	SMA Board Edge	Linx	CON SMA003.062
37	4	J70, JP1, JP50, JP71	.1" Male Vert.	Würth	61300211121
38	3	JP10, JP72, JP100	.1" Shunt Jumper	Würth	60900213421
39	1	L60	100 μ H 2.2 A	Würth	744871101
40	1	L80	10 μ H 150 mA	Würth	74479778310
41	1	L90	47 μ H 250 mA	Würth	7440329470
42	1	Lsns (Only Populate with Tsns1)	82 nH (only with Tsns1)	CoilCraft	1515SQ-82NJEB
43	2	Lzvs1, Lzvs2	390 nH	CoilCraft	2929SQ-391JE
44	1	P25	10 k Ω	Murata	PV37Y103C01B00
45	2	P71, P72	1 k Ω	Murata	PV37Y102C01B00
46	3	Q1	100 V 220 m Ω with Sync Boot FET	EPC	EPC2107
47	3	Q2, Q3, Q60	100 V 65 m Ω	EPC	EPC2036
48	1	Q20, Q46, Q135	100 V 2.8 Ω	EPC	EPC2038
49	3	Q61 (Not Populated)	100 V 6 A 30 m Ω	EPC	EPC2007C
50	1	R132, R200, R222	18 k Ω 1%	Panasonic	ERJ-2RKF1802X
51	1	R133	6.81 k Ω 1%	Panasonic	ERJ-2RKF6811X
52	2	R134	470 k Ω	Panasonic	ERJ-2RKF4703X
53	1	R2, R82	20 Ω	Panasonic	ERJ-2RKF20R0X
54	1	R201	4.53 k Ω 1%	Panasonic	ERJ-2RKF4531X
55	1	R21	51 Ω 1/2 W (with Tsns2), 10 k Ω (with Tsns1)	Panasonic	ERJ-P06J510V / ERJ-P06J103V

(continued on next page)

Table 3: Bill of Materials - Amplifier Board (continued)

Item	Qty	Reference	Part Description	Manufacturer	Part #
56	1	R220	71.5 kΩ	Panasonic	ERJ-3EKF7152V
57	1	R223	6.8 kΩ 1%	Panasonic	ERJ-2RKF6801X
58	1	R224	330 kΩ	Panasonic	ERJ-2RKF3303X
59	1	R25	4.3kΩ 1% (with Tsns2), 6.81 kΩ (with Tsns1)	Panasonic	ERJ-2RKF4301X / ERJ-2RKF6811X
60	1	R26	22 kΩ 1% (with Tsns2), 2.8 kΩ (with Tsns1)	Panasonic	ERJ-2RKF2202X / ERJ-2RKF2801X
61	1	R27	3.3 kΩ 1%	Panasonic	ERJ-2RKF3301X
62	4	R3	27 kΩ	Panasonic	ERJ-2RKF2702X
63	1	R30, R102, R103, R104	100 Ω	Panasonic	ERJ-3EKF1000V
64	1	R31	71 kΩ 5 1%	Panasonic	ERJ-6ENF7152V
65	1	R32	8.2 kΩ 1%	Panasonic	ERJ-2RKF8201X
66	2	R33	75 kΩ	Panasonic	ERJ-2RKF7502X
67	1	R35, R36	634 Ω	Panasonic	ERJ-2RKF6340X
68	2	R37	150 kΩ 1%	Panasonic	ERJ-2RKF1503X
69	1	R38, R91	49.9 kΩ 1%	Panasonic	ERJ-2RKF4992X
70	4	R4	4.7 Ω	Stackpole	RMCF0402FT4R70
71	4	R40, R130, R202, R203	261 kΩ	Panasonic	ERJ-3EKF2613V
72	1	R41, R49, R131, R221	6.04 kΩ	Panasonic	ERJ-2RKF6041X
73	2	R42	36.5 kΩ	Panasonic	ERJ-2RKF3652X
74	1	R43, R48	15.4 kΩ	Panasonic	ERJ-2RKF1542X
75	1	R45 (Not Populated)	1.5 kΩ	Panasonic	ERJ-2RKF1501X
76	2	R44, R90	100 kΩ 1%	Panasonic	ERJ-2RKF1003X
77	2	R46, R135	11.3 kΩ	Panasonic	ERJ-2RKF1132X
78	1	R50	10 Ω	Panasonic	ERJ-3EKF10R0V
79	1	R51	124 kΩ 1%	Panasonic	ERJ-2RKF1243X
80	1	R52	71.5 kΩ 1%	Panasonic	ERJ-2RKF7152X
81	1	R53	1.00 kΩ	Panasonic	ERJ-2RKF1001X
82	1	R54	0 Ω	Panasonic	ERJ-2GE0R00X
83	1	R60	80 mΩ 0.4 W	Vishay Dale	WSLP0603R0800FEB
84	1	R61	220 mΩ 0.333 W	Susumu	RL1220S-R22-F
85	1	R70	47 kΩ	Panasonic	ERJ-2RKF4702X
86	1	R71	430 Ω	Panasonic	ERJ-2RKF4300X
87	1	R72	180 Ω	Panasonic	ERJ-2RKF1800X
88	5	R73, R76, R77, R100, R101	10 kΩ	Panasonic	ERJ-2RKF1002X
89	1	R75	68 kΩ	Panasonic	ERJ-2RKF6802X
90	1	R80	2.2 Ω	Stackpole	RMCF0402FT2R20
91	1	R92	9.53 kΩ 1%	Panasonic	ERJ-2RKF9531X
92	2	TP1, TP2	SMD Probe Loop	Keystone	5015
93	1	Tsns1 (Not Populated)	10 μH 1:1 96.9%	CoilCraft	PFD3215-103ME
94	1	Tsns2	1:20 Current Xmr	CoilCraft	CST7030-020LB
95	1	U1	100 V eGaN Driver	National Semiconductor	LM5113TM
96	3	U130, U200, U220	Comparator	Texas Instruments	TLV3201AIDBVR
97	1	U210	+Edge-trig D-Flop with Clr & Rst	Fairchild	NC7SZ74L8X
98	1	U30	Power & Current Monitor	Linear	LT2940IMS#PBF
99	1	U50	Boost Controller	Texas Instruments	LM3478 mAX/NOPB
100	1	U70	Pgm Osc.	EPSON	SG-8002CE-PHB-6.780MHz
101	1	U71	2 In NAND	Fairchild	NC7SZ00L6X
102	1	U72	2 In AND	Fairchild	NC7SZ08L6X
103	1	U75	Dither Oscillator	mAxim	DS1090U-32+
104	1	U77	MUX	Fairchild	NC7SZ157L6X
105	1	U78	Reconfig Logic 57	Fairchild	NC7SZ57L6X
106	1	U80	Gate Driver with LDO	Texas Instruments	UCC27611DRV
107	1	U90	1.4 MHz 24 V 0.5 A Buck	MPS	MP2357DJ-LF
108	1	PCB	EPC9511 Amplifier Board	EPC	B5008 Rev. 1.0

Table 4: Off Board Components

Item	Qty	Reference	Part Description	Manufacturer	Part #
1	1	SW1000	Rocker SW SPDT 120 V 5 A	E-Switch	100SP3T1B1M1QE8
2	2	D1000, D1001	40x12mm LED backlight	BCrobotics	LEDB-003
3	1	J1000	Con4x1.1F	TE Connectivity	534237-2

Table 5: Bill of Materials - Source Coil

Item	Qty	Reference	Part Description	Manufacturer	Part #
1	1	C1	DNP	—	—
2	1	C2	DNP	—	—
3	1	C3	390 pF, 500 V	Johanson	501S42E391JV3E
4	1	Ctrmb	560 pF, 500 V	Johanson	501S42E561JV3E
5	1	C20	100 nF, 100 V	Kemet	C1812C104J1GACTU
6	1	C21	47 nF, 100 V	TDK	C4532COG2A473J200KA
7	1	C22	12 nF, 50 V	Murata	GRM2195C1H123JA01D
8	1	C30	1000 pF, 200 V	Johanson	201S42E102GV3E
9	1	C31	68 pF, 1500 V	Johanson	152S42E680GV3E
10	1	L30	270 nH	CoilCraft	2222SQ-271JE
11	1	J1	SMA Edge	Linx	CON SMA013.031
12	1	PCB	Multi-mode Coil - with ferrite	NuCurrent	NC21-T118L01-152-113-1R10

Table 6: Bill of Materials for the Category-3 AirFuel Device Board

Item	Qty	Reference	Part Description	Manufacturer	Part #
1	1	C84	100 nF, 50 V	Würth	885012206095
2	1	C85	10 µF, 50 V	Murata	GRM32DF51H106ZA01L
3	2	CM1, CM11	470 pF, 500 V	Johanson	501S42E471JV3E
4	4	CM2, CM12, CMP1, CMP2	DNP	—	—
5	4	CM5, CM7, CMP3, CMP4	DNP	—	—
6	1	CM6	56 pF, 500 V	Johanson	501S42E560JV3E
7	1	CM8	68 pF, 500 V	Johanson	501S42E680JV3E
8	4	D80, D81, D82, D83	40 V 1A	Diodes Inc.	PD3S140-7
9	1	D84	LED 0603 Green	Würth	150060VS75000
10	1	D85	2.7 V 250 mW	NXP	BZX84-C2V7,215
11	1	D86	LED 0603 Red	Würth	150060RS75000
12	1	D87	33 V 250 mW	NXP	BZX84-C33,215
13	2	J81, J82	.1" Male Vert.	Würth	61300211121
14	2	LM1, LM11	82 nH	Würth	744912182
15	1	R80	300 mΩ 1 W	Stackpole	CSRN2512FKR300
16	1	R81	4.7 kΩ	Stackpole	RMCF1206FT4K70
17	1	R82	422 Ω	Yageo	RMCF0603FT422R
18	4	TP1, TP2, TP3, TP4	SMD Probe Loop	Keystone	5015
19	1	PCB	AirFuel Cat3 Device	EPC	B5012

EPC would like to acknowledge Würth Electronics (www.we-online.com/web/en/wuerth_elektronik/start.php), Coilcraft (www.coilcraft.com), and KDS Daishinku America (www.kdsamerica.com) for their support of this project.

Table 7: Bill of Materials for the Qi/PMA Compatible Device Board

Item	Qty	Reference	Part Description	Manufacturer	Part #
1	1	C84	100 nF, 50 V	Würth	885012206095
2	1	C85	10 µF 50 V	Murata	GRM32DF51H106ZA01L
3	1	CI1	7.5 µH 3 A	Würth	760308102210
4	1	CM1	12 nF 50 V	Murata	GRM2195C1H123JA01D
5	1	CM2	100 nF 50 V	Würth	885012208087
6	2	CM5, CM6	DNP	—	—
7	1	CMP1	DNP	—	—
8	4	D80, D81, D82, D83	40V 1A	Diodes Inc.	PD3S140-7
9	1	D84	LED 0603 Green	Würth	150060VS75000
10	1	D85	2.7 V 250 mW	NXP	BZX84-C2V7,215
11	1	D86	LED 0603 Red	Würth	150060RS75000
12	1	D87	33V 250mW	NXP	BZX84-C33,215
13	2	J81, J82	.1" Male Vert.	Würth	61300211121
14	1	R80	300 mΩ 1W	Stackpole	CSRN2512FKR300
15	1	R81	4.7 kΩ	Stackpole	RMCF1206FT4K70
16	1	R82	422 Ω	Yageo	RMCF0603FT422R
17	4	TP1, TP2, TP3, TP4	SMD Probe Loop	Keystone	5015
18	1	PCB	Inductive Device	EPC	B5011

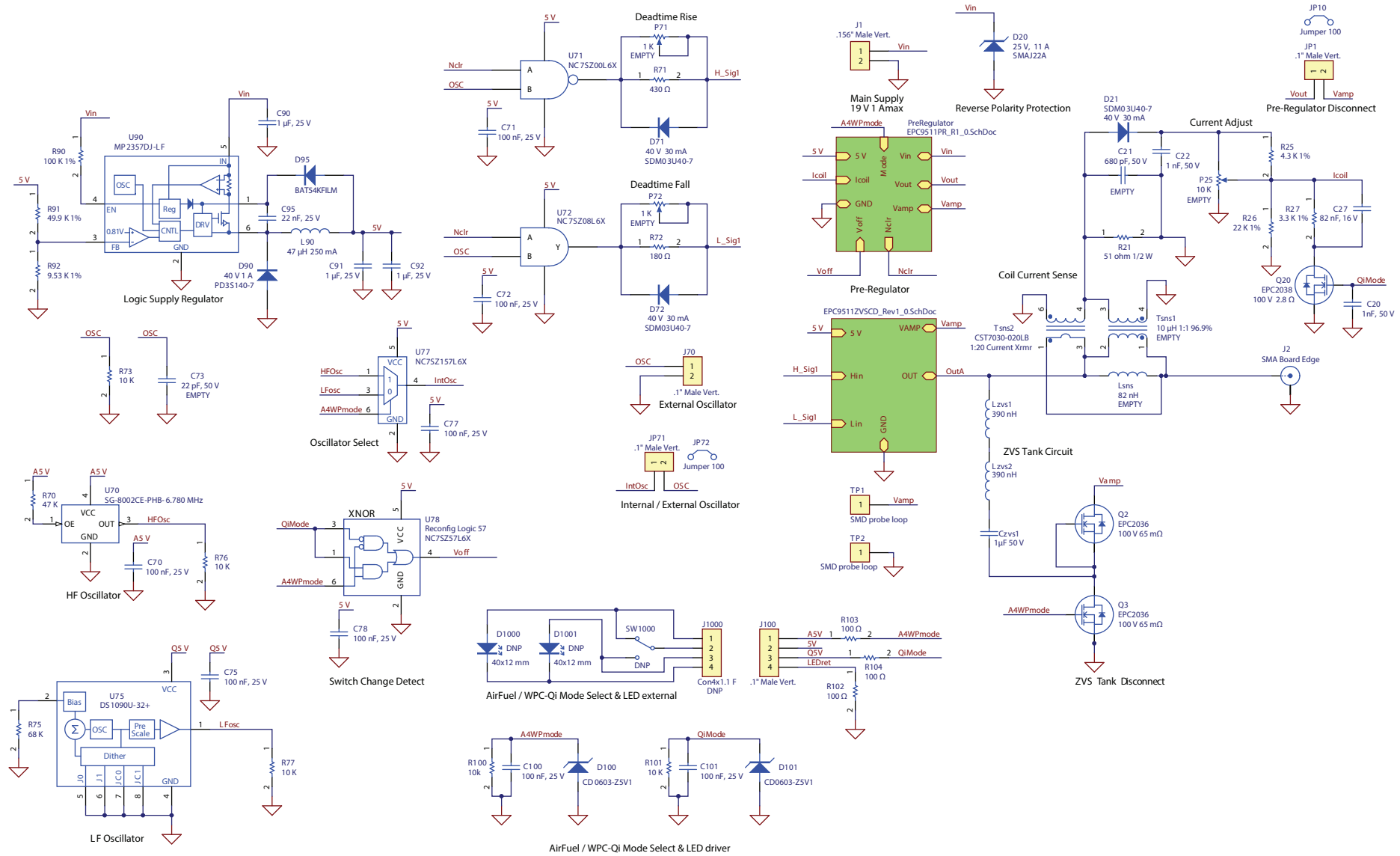

Figure 13: EPC9511 - ZVS class-D amplifier schematic

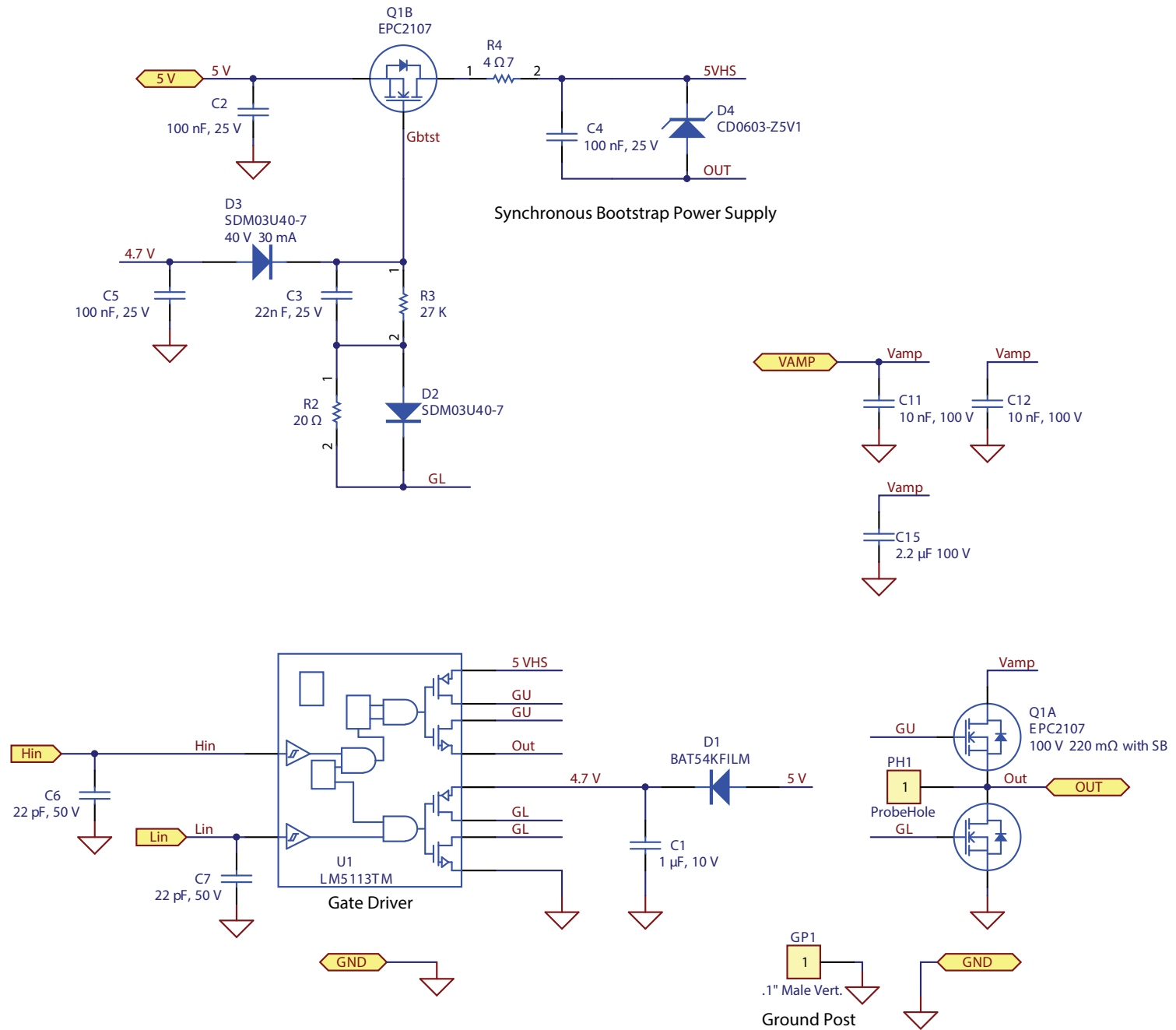

Figure 14: EPC9511 - Gate driver and power devices schematic

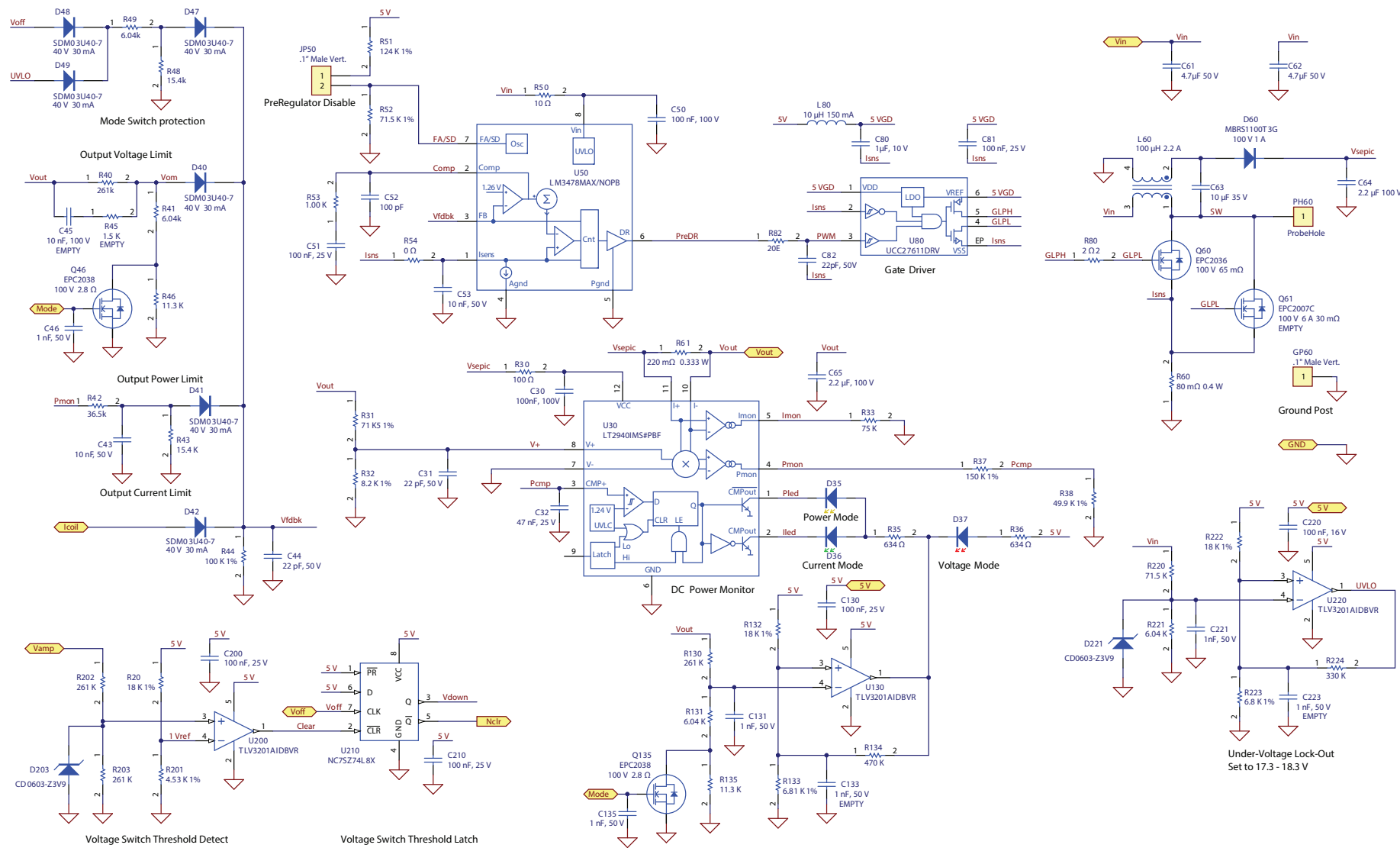

Figure 15: EPC9511 - Pre-regulator schematic

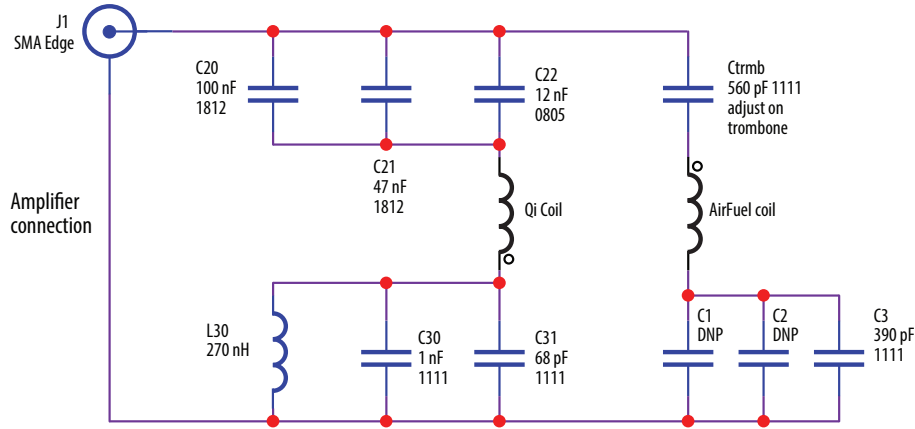

Figure 16: Source coil schematic

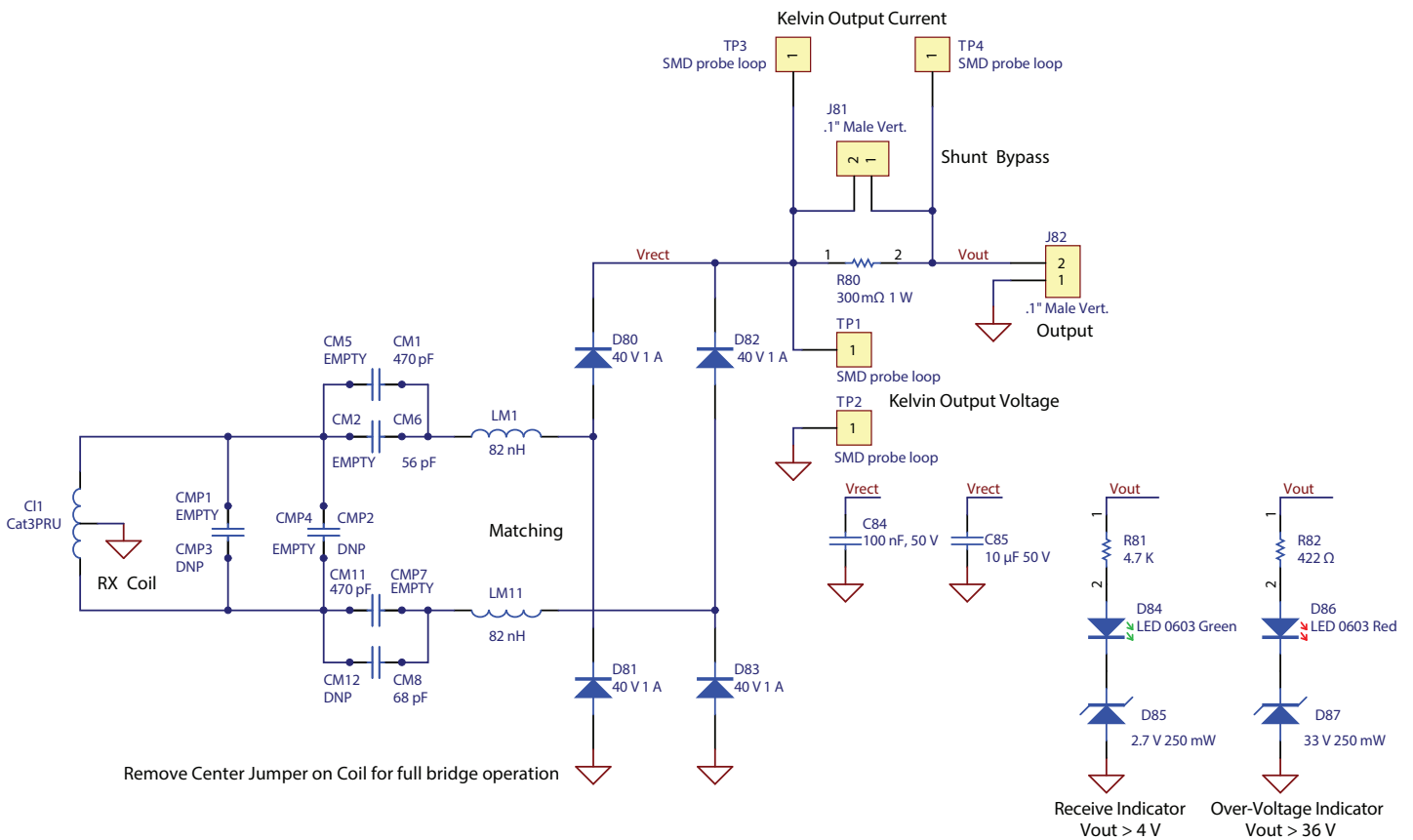

Figure 17: Category-3 AirFuel device schematic

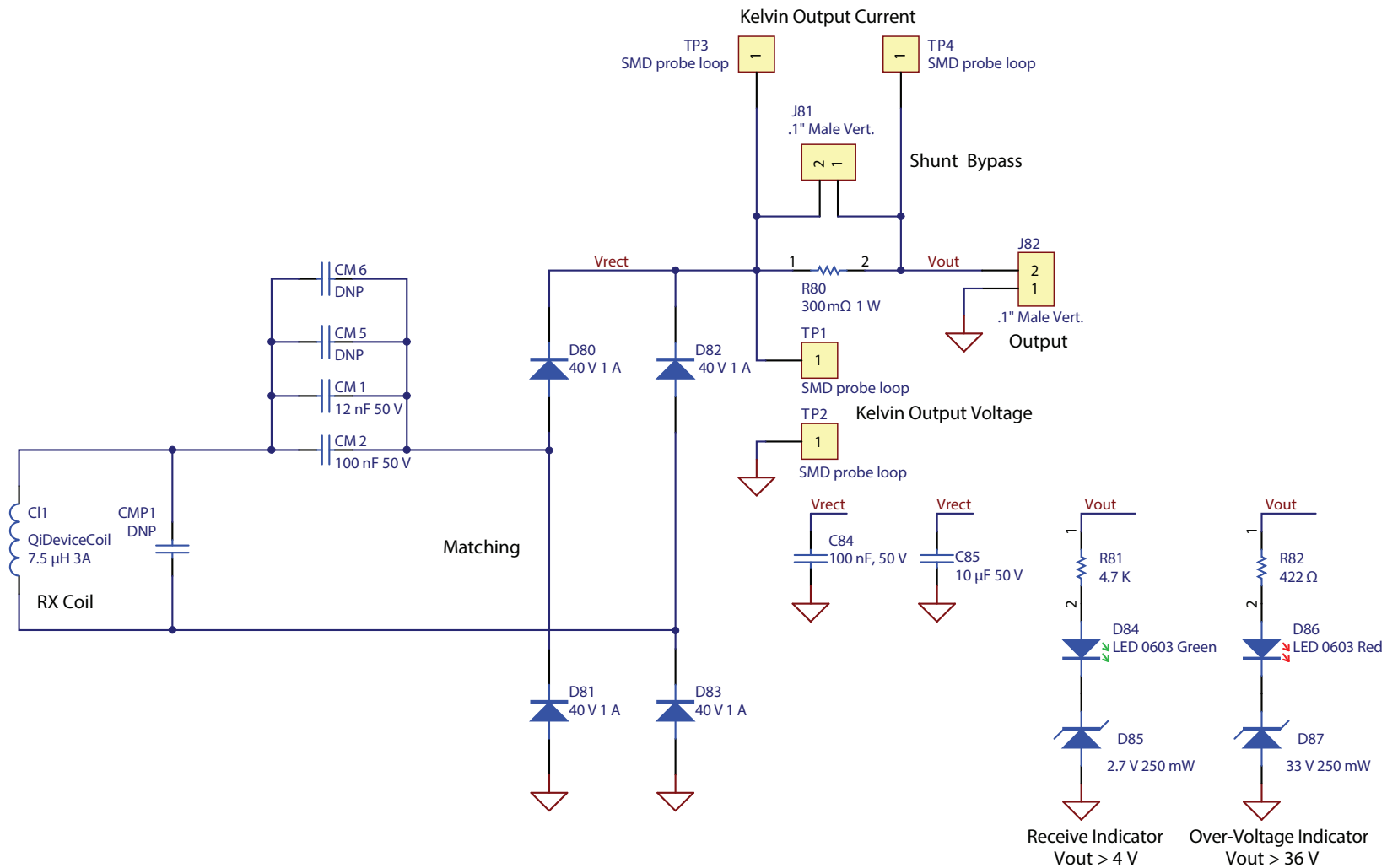

Figure 18: Qi/PMA device schematic



EPC would like to acknowledge Würth Elektronik (www.we-online.com) for their support of this project.

Würth Elektronik is a premier manufacturer of electronic and electromechanical passive components. EPC has partnered up with WE for a variety of passive component requirements due to the performance, quality and range of products available. EPC9121 development board features various WE product lines including a wireless power charging coil, power inductors, capacitors, LEDs and connectors.

One of the highlights on the board is the 37 x 37 mm sized wireless power charging receiver coil engineered out of Würth Elektronik's design center in Munich, Germany. Based off of EPC's transmitting and receiving controller requirements, the coils and associated capacitors have been carefully selected to optimize efficiency for power transfer as well as meet compliance for the Qi charging standard. Litzwire and high permeability materials are utilized in construction of the coil to yield the highest Q-factor possible. Pot core construction minimize undesirable stray magnetic fields. The coils have been built and endurance tested beyond what the industry calls for due to its commitment to quality standards as a German company.

Also featured on the board are a wide range of Würth Elektronik power inductor technologies including the WE-DD coupled, WE-PMI multilayer chip and WE-AIR air core inductors. The inductors very chosen for their balance between size, efficiency, and power handling. Lowest core losses where applicable. High current handling capability. Extremely low DCR losses. Magnetically shielded where applicable. Engineered for reliability.

Learn more at www.we-online.com.



EPC would like to acknowledge Johanson Technology (www.johansontechnology.com) for their support of this project. Information on the capacitors used in this kit can be found at <http://www.johansontechnology.com/S42E>.



EPC would like to acknowledge NuCurrent (www.NuCurrent.com) for their support of this project.

NuCurrent is a leading developer of high-efficiency antennas for wireless power applications. Compliant across Alliance for Wireless Power (A4WP), Wireless Power Consortium (Qi) and Power Matters Alliance (PMA) standards, NuCurrent works closely with electronic device OEMs and integrators to custom-design, rapid-prototype and integrate the optimal antenna for a broad range of applications. NuCurrent's patented designs, structures and manufacturing techniques mitigate typical high frequency effects, offering higher efficiency, smaller sizes, higher durability and lower cost with wireless power application development.

For more information, visit <http://nucurrent.com>

Logos and trademarks belong to the respective owner. AirFuel™ logo used with permission.

Note that this demonstration kit is not compliant with any wireless power standard. It can be used to evaluate wireless power transfer according to the standards and is meant as a tool to evaluate eGaN® FETs and eGaN® ICs in this application.

For More Information:

Please contact info@epc-co.com
or your local sales representative

Visit our website:

www.epc-co.com

Sign-up to receive
EPC updates at
bit.ly/EPCupdates
or text "EPC" to 22828



EPC Products are distributed through Digi-Key.

www.digikey.com

Demonstration Board Notification

The EPC9121 board is intended for product evaluation purposes only and is not intended for commercial use. Replace components on the Evaluation Board only with those parts shown on the parts list (or Bill of Materials) in the Quick Start Guide. Contact an authorized EPC representative with any questions.

This board is intended to be used by certified professionals, in a lab environment, following proper safety procedures. Use at your own risk.

As an evaluation tool, this board is not designed for compliance with the European Union directive on electromagnetic compatibility or any other such directives or regulations. As board builds are at times subject to product availability, it is possible that boards may contain components or assembly materials that are not RoHS compliant. Efficient Power Conversion Corporation (EPC) makes no guarantee that the purchased board is 100% RoHS compliant.

The Evaluation board (or kit) is for demonstration purposes only and neither the Board nor this Quick Start Guide constitute a sales contract or create any kind of warranty, whether express or implied, as to the applications or products involved.

Disclaimer: EPC reserves the right at any time, without notice, to make changes to any products described herein to improve reliability, function, or design. EPC does not assume any liability arising out of the application or use of any product or circuit described herein; neither does it convey any license under its patent rights, or other intellectual property whatsoever, nor the rights of others.