



Chipsmall Limited consists of a professional team with an average of over 10 year of expertise in the distribution of electronic components. Based in Hongkong, we have already established firm and mutual-benefit business relationships with customers from,Europe,America and south Asia,supplying obsolete and hard-to-find components to meet their specific needs.

With the principle of “Quality Parts,Customers Priority,Honest Operation,and Considerate Service”,our business mainly focus on the distribution of electronic components. Line cards we deal with include Microchip,ALPS,ROHM,Xilinx,Pulse,ON,Everlight and Freescale. Main products comprise IC,Modules,Potentiometer,IC Socket,Relay,Connector.Our parts cover such applications as commercial,industrial, and automotives areas.

We are looking forward to setting up business relationship with you and hope to provide you with the best service and solution. Let us make a better world for our industry!



Contact us

Tel: +86-755-8981 8866 Fax: +86-755-8427 6832

Email & Skype: info@chipsmall.com Web: www.chipsmall.com

Address: A1208, Overseas Decoration Building, #122 Zhenhua RD., Futian, Shenzhen, China



LISTED BY UL/cUL

版数 REV.	年月日 DATE	CN NO.	変更内容 DESCRIPTION	製図 DR.	担当 CHK.	査閲 APPD.	承認 APPD.
------------	-------------	--------	---------------------	-----------	------------	-------------	-------------

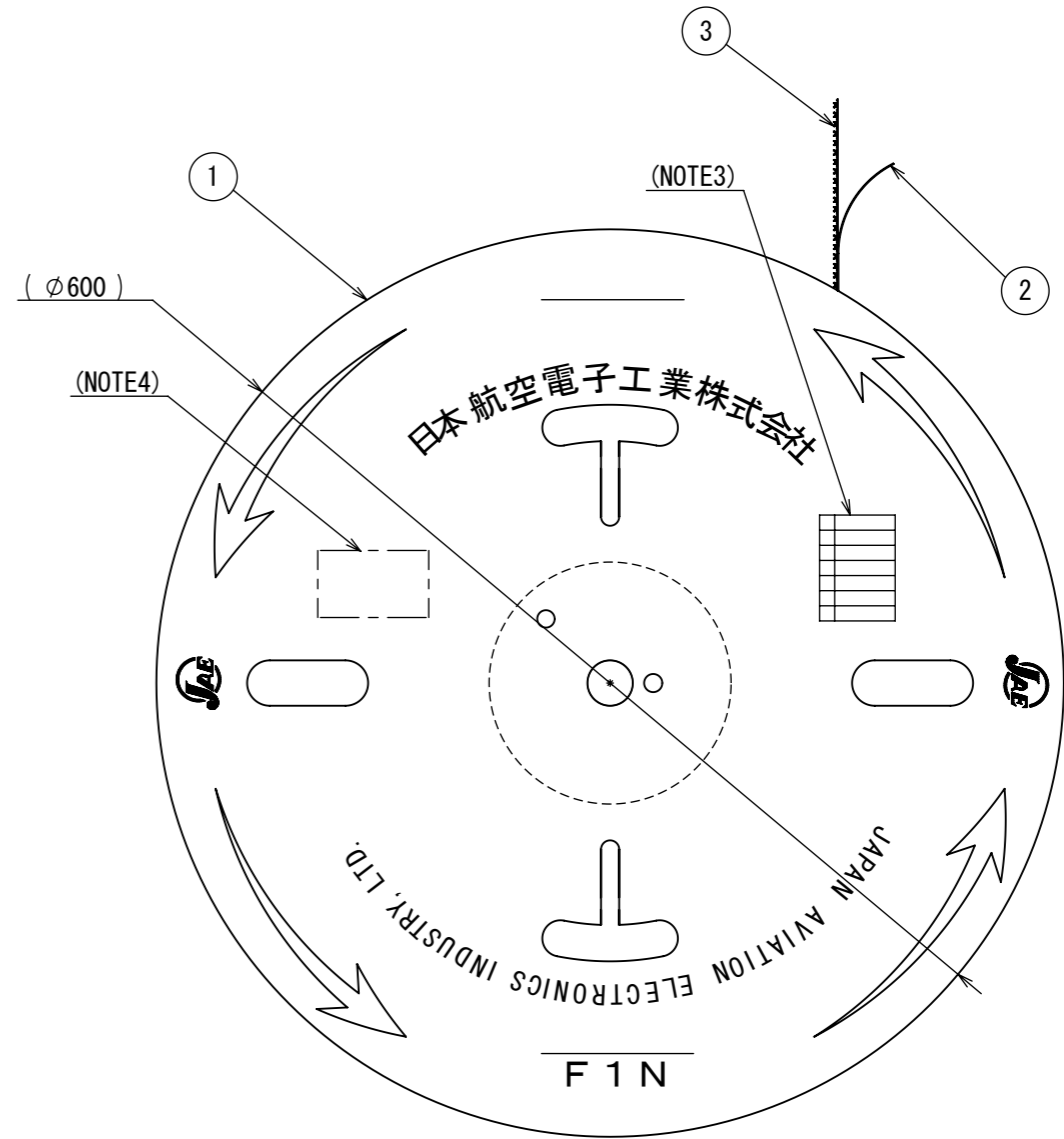
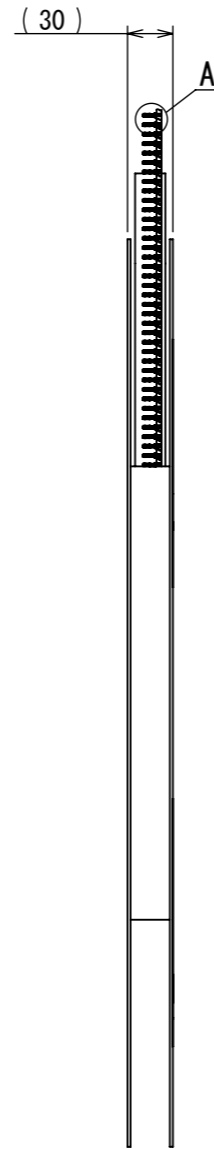
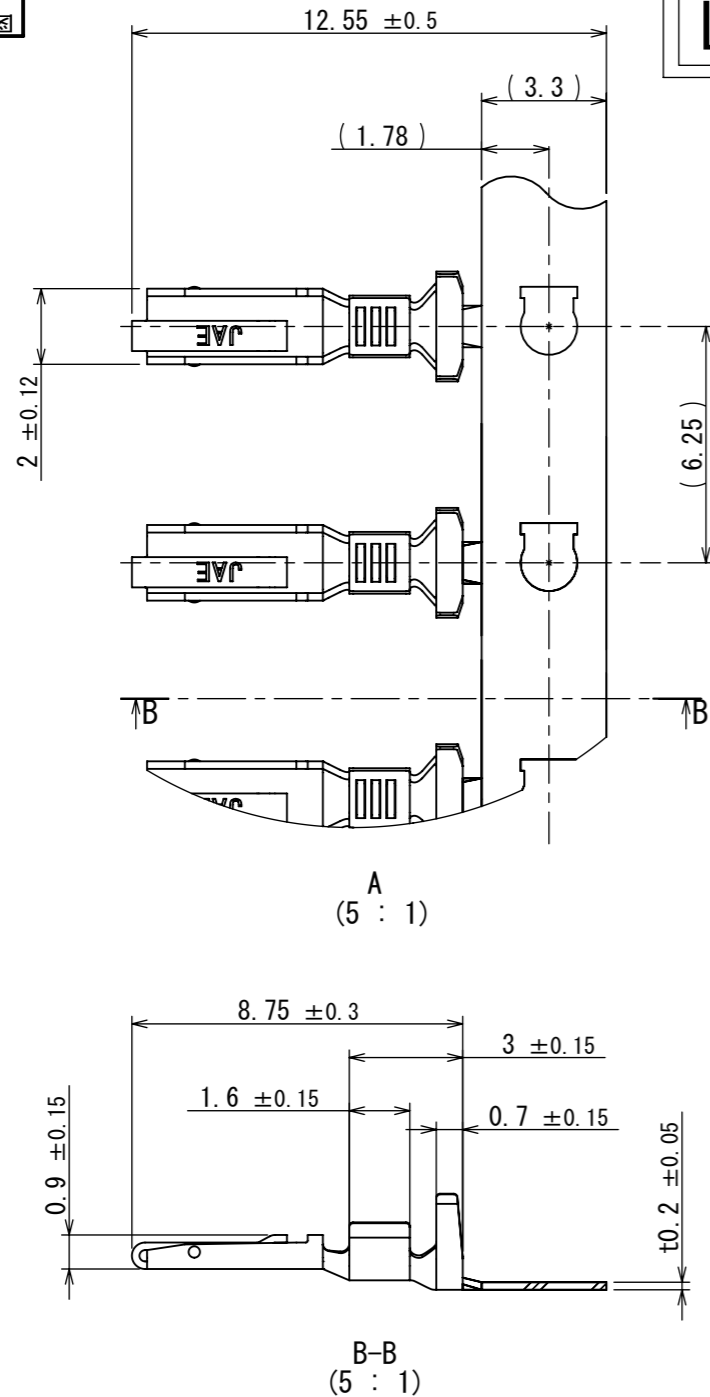

- NOTE1. CONTACTS ARE SUPPLIED IN REELED FORM WITH 9000 CONTACTS PER REEL.
 NOTE2. APPLICABLE WIRE DIMETER : AWG#24~#26、INSULATION DIA : φ0.9~φ1.6
 NOTE3. MARK TRADE NAME AND NO. OF CONTACTS.
 NOTE4. THE LABEL IN WHICH RECOGNIZED COMPONENT MARK IS ATTACHED.
- 注1. 本品は9000本のリール状のものです。
 注2. 適用電線仕様 : AWG#24~#26、被覆外径 : φ0.9~φ1.6
 注3. 図示の位置に、品名、数量等を記入したラベルが貼られます。
 注4. 図示の位置にcULus認証品の必要事項を表示したラベルが貼られます。

3	CONTACT	9000	COPPER ALLOY	LEAD-FREE TIN PLATING	
2	PAPER TAPE	1	PAPER		
1	REEL	1	PAPER		
符号 NO.	名称 DESCRIPTION	個数 QTY.	材料 MATERIAL	仕上 FINISH	備考 REMARKS

仕様書 (SPECIFICATION) JACS-10914 JAHL-10914		第1版 (ORIGINAL DATE) 13/FEB/2012		尺度 (SCALE) 1:50	シリーズ (SERIES) ES5	製図 DR.	日本航空電子工業株式会社
一般公差 (GENERAL TOLERANCE) 寸法 (DIMENSION)		角度 (ANGLES)		名称 (TITLE) ES5P09K5FA CONTACT		担当 CHK. K. SHIMOJI	JAE JAPAN AVIATION ELECTRONICS INDUSTRY, LTD.
. ±0.8 . × ±0.4 . ×× ±0.1 . ××× ±		×° ± ×°×' ±		質量 (MASS)		査閲 APPD. N. IKENAGA	
						承認 APPD. T. KUDOU	図面番号 (DRAWING NO.) SJ112417
							版数 (REV.) 1