



Chipsmall Limited consists of a professional team with an average of over 10 year of expertise in the distribution of electronic components. Based in Hongkong, we have already established firm and mutual-benefit business relationships with customers from,Europe,America and south Asia,supplying obsolete and hard-to-find components to meet their specific needs.

With the principle of “Quality Parts,Customers Priority,Honest Operation,and Considerate Service”,our business mainly focus on the distribution of electronic components. Line cards we deal with include Microchip,ALPS,ROHM,Xilinx,Pulse,ON,Everlight and Freescale. Main products comprise IC,Modules,Potentiometer,IC Socket,Relay,Connector.Our parts cover such applications as commercial,industrial, and automotives areas.

We are looking forward to setting up business relationship with you and hope to provide you with the best service and solution. Let us make a better world for our industry!



Contact us

Tel: +86-755-8981 8866 Fax: +86-755-8427 6832

Email & Skype: info@chipsmall.com Web: www.chipsmall.com

Address: A1208, Overseas Decoration Building, #122 Zhenhua RD., Futian, Shenzhen, China



ESD52233

Delay-on-Make/Interval

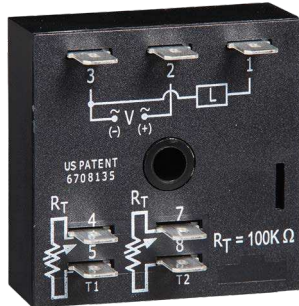

Wiring Diagram

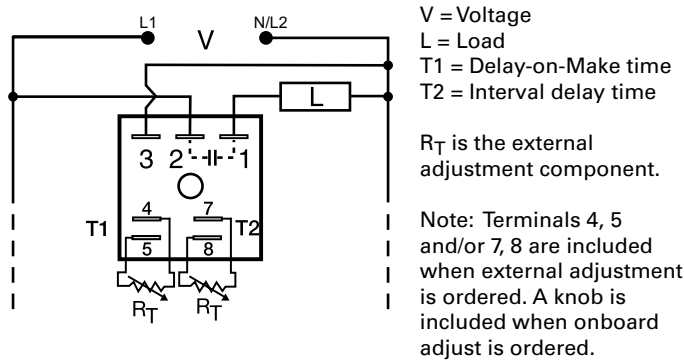

Description

The ESD5 Series is an accurate, solid-state, delayed interval timer. It offers a 1A steady, 10A inrush output and is available with adjustable or fixed time delays of 0.1 seconds to 1000 minutes in six ranges. Input voltages of 24, 120, or 230VAC are available. Encapsulation offers protection against shock and vibration. Adjustment options are factory fixed, onboard or externally adjustable. The repeat accuracy, under stable conditions, is 0.1%. The factory calibration of the time delay is $\pm 5\%$.

Operation (Delayed Interval)

Upon application of input voltage, the T1 delay-on-make time delay begins and the output remains de-energized. At the end of this delay, the output energizes and the T2 interval delay begins. At the end of the interval delay period, the output de-energizes.

Reset: Removing input voltage resets the output and the time delays, and returns the sequence to the first delay.

Features & Benefits

FEATURES	BENEFITS
Compact, low cost design measuring 2 in. (50.8mm) square	Allows flexibility for OEM applications and reduces component and labor costs
Microcontroller based	Repeat Accuracy + / - 0.1%, Factory calibration + / - 5%
1A steady, 10A inrush solid-state output	Provides 100 million operations in typical conditions.
Totally solid state and encapsulated	No moving parts to arc and wear out over time and encapsulated to protect against shock, vibration, and humidity

Accessories



P1004-95, P1004-95-X Versa-Pot
Panel mountable, industrial potentiometer recommended for remote time delay adjustment.



P1023-6 Mounting bracket
The 90° orientation of mounting slots makes installation/removal of modules quick and easy.



P0700-7 Versa-Knob
Designed for 0.25 in. (6.35 mm) shaft of Versa-Pot. Semi-gloss industrial black finish.



P1015-64 (AWG 14/16) Female Quick Connect
These 0.25 in. (6.35 mm) female terminals are constructed with an insulator barrel to provide strain relief.



P1015-18 Quick Connect to Screw Adapter
Screw adapter terminal designed for use with all modules with 0.25 in. (6.35 mm) male quick connect terminals.



C103PM (AL) DIN Rail
35 mm aluminum DIN rail available in a 36 in. (91.4 cm) length.



P1023-20 DIN Rail Adapter
Allows module to be mounted on a 35 mm DIN type rail with two #10 screws.

ESD52233

External Resistance vs. Time Delay

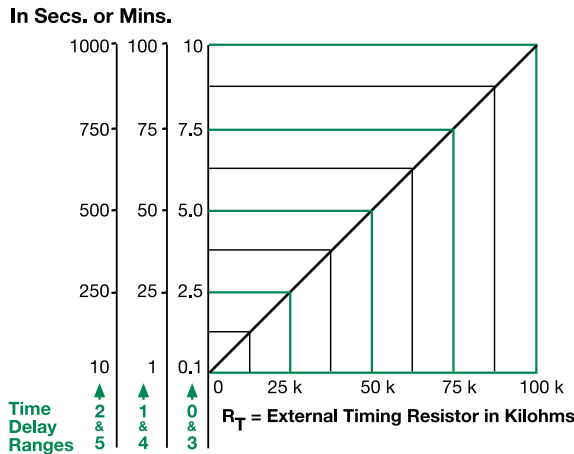

This chart applies to externally adjustable part numbers.
The time delay is adjustable over the time delay range selected by varying the resistance across the R_T terminals; as the resistance increases the time delay increases.

When selecting an external R_T , add the tolerances of the timer and the R_T for the full time range adjustment.

Examples: 1 to 50 S adjustable time delay, select time delay range 1 and a 50 K ohm R_T . For 1 to 100 S use a 100 K ohm R_T .

Function Diagram

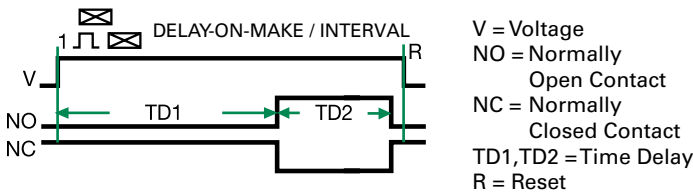

Specifications

Time Delay Range	0.1s - 1000m in 6 adjustable ranges or fixed
Repeat Accuracy Tolerance (Factory Calibration)	$\pm 0.1\%$ or 20ms, whichever is greater
Reset Time	≤ 150 ms
Time Delay vs Temp. & Voltage	$\leq \pm 2\%$
Input Voltage Tolerance	24VAC $\pm 20\%$
AC Line Frequency	50/60 Hz
Power Consumption	≤ 2 VA
Output Type	Solid state
Rating	1A steady state, 10A inrush at 60°C
OFF State Leakage Current	≈ 5 mA @ 230VAC
Voltage Drop	≈ 2.5 V @ 1A
Protection	Encapsulated
Circuitry	≥ 2000 V RMS terminals to mounting surface
Dielectric Breakdown	≥ 100 M Ω
Insulation Resistance	
Mechanical Mounting	Surface mount with one #10 (M5 x 0.8) screw
Dimensions	H 50.8 mm (2"); W 50.8 mm (2"); D 30.7 mm (1.21")
Termination	0.25 in. (6.35 mm) male quick connect terminals
Environmental Operating/Storage Temperature	-40° to 75°C / -40° to 85°C
Humidity	95% relative, non-condensing
Weight	≈ 2.4 oz (68g)