



Chipsmall Limited consists of a professional team with an average of over 10 year of expertise in the distribution of electronic components. Based in Hongkong, we have already established firm and mutual-benefit business relationships with customers from,Europe,America and south Asia,supplying obsolete and hard-to-find components to meet their specific needs.

With the principle of “Quality Parts,Customers Priority,Honest Operation,and Considerate Service”,our business mainly focus on the distribution of electronic components. Line cards we deal with include Microchip,ALPS,ROHM,Xilinx,Pulse,ON,Everlight and Freescale. Main products comprise IC,Modules,Potentiometer,IC Socket,Relay,Connector.Our parts cover such applications as commercial,industrial, and automotives areas.

We are looking forward to setting up business relationship with you and hope to provide you with the best service and solution. Let us make a better world for our industry!



Contact us

Tel: +86-755-8981 8866 Fax: +86-755-8427 6832

Email & Skype: info@chipsmall.com Web: www.chipsmall.com

Address: A1208, Overseas Decoration Building, #122 Zhenhua RD., Futian, Shenzhen, China



2N Detector Switches

Type: **ESE22**

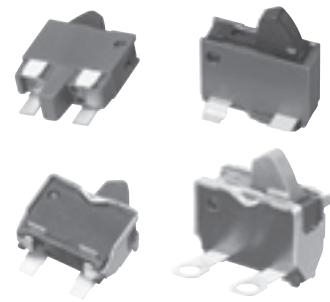

■ Features

- Can be operated with different actuation angles (horizontally and vertically)
- Reflow soldering
- Light operating force

■ Recommended Applications

- Detection of media in portable electronic equipment

■ Explanation of Part Numbers

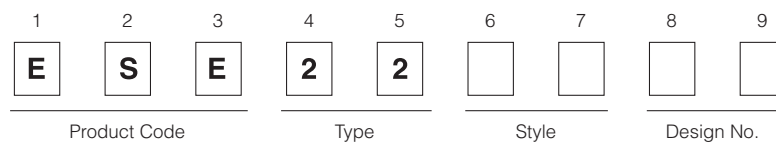

■ Specifications

Rating	50 μ A 3 V DC to 10 mA 5 V DC (Resistive load)
Contact Resistance	500 m Ω max. (Initial)
Insulation Resistance	100 M Ω min. (100 V DC)
Dielectric Withstanding Voltage	100 V AC for 1 minute
Operating Force	300 mN max.
Mounting Height	<ul style="list-style-type: none"> · Type MV 4.1 mm · Type MH 2.1 mm · Type MH with Frame 2.85 mm
Poles and Throws	1-pole 1-throw
Full Travel (Pushing distance)	<ul style="list-style-type: none"> · Type MV 4.25 mm(2.05 mm) · Type MH 1.2 mm(2.0 mm) · Type MH with Frame 0.6 mm(2.0 mm)
Operating Life	50,000 cycles min.
Temperature Range	-10 °C to +70 °C
Heat Resistance	+80 °C for 96 hours
Low Temperature Resistance	-25 °C for 96 hours
Humidity Resistance	+40 °C 90 % to 95 % RH for 96 hours
Minimum Quantity/Packing Unit	500 pcs. Polyethylene Bag (Bulk)
	<ul style="list-style-type: none"> · Type MV 1,000 pcs. Embossed Taping (Reel Pack) · Type MH with Frame 3,000 pcs. Embossed Taping (Reel Pack) · Type MH 4,000 pcs. Embossed Taping (Reel Pack)
	10,000 pcs. Polyethylene Bag (Bulk)
Quantity/Carton	<ul style="list-style-type: none"> · Type MV 6,000 pcs. Embossed Taping (Reel Pack) · Type MH with Frame 18,000 pcs. Embossed Taping (Reel Pack) · Type MH 24,000 pcs. Embossed Taping (Reel Pack)

Design and specifications are each subject to change without notice. Ask factory for the current technical specifications before purchase and/or use. Should a safety concern arise regarding this product, please be sure to contact us immediately.

■ Dimensions in mm (not to scale)

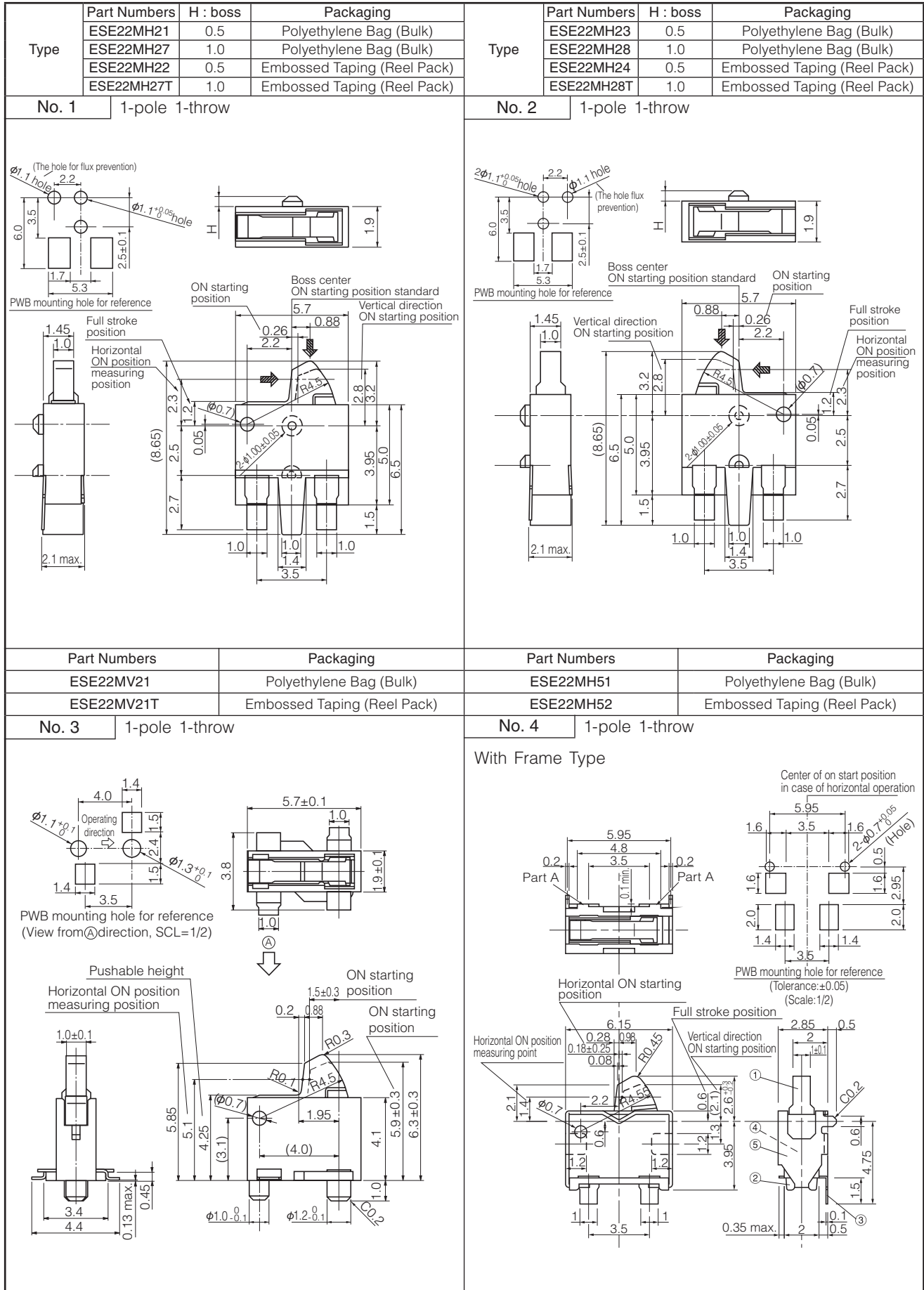

Design and specifications are each subject to change without notice. Ask factory for the current technical specifications before purchase and/or use. Should a safety concern arise regarding this product, please be sure to contact us immediately.

■ Dimensions in mm (not to scale)

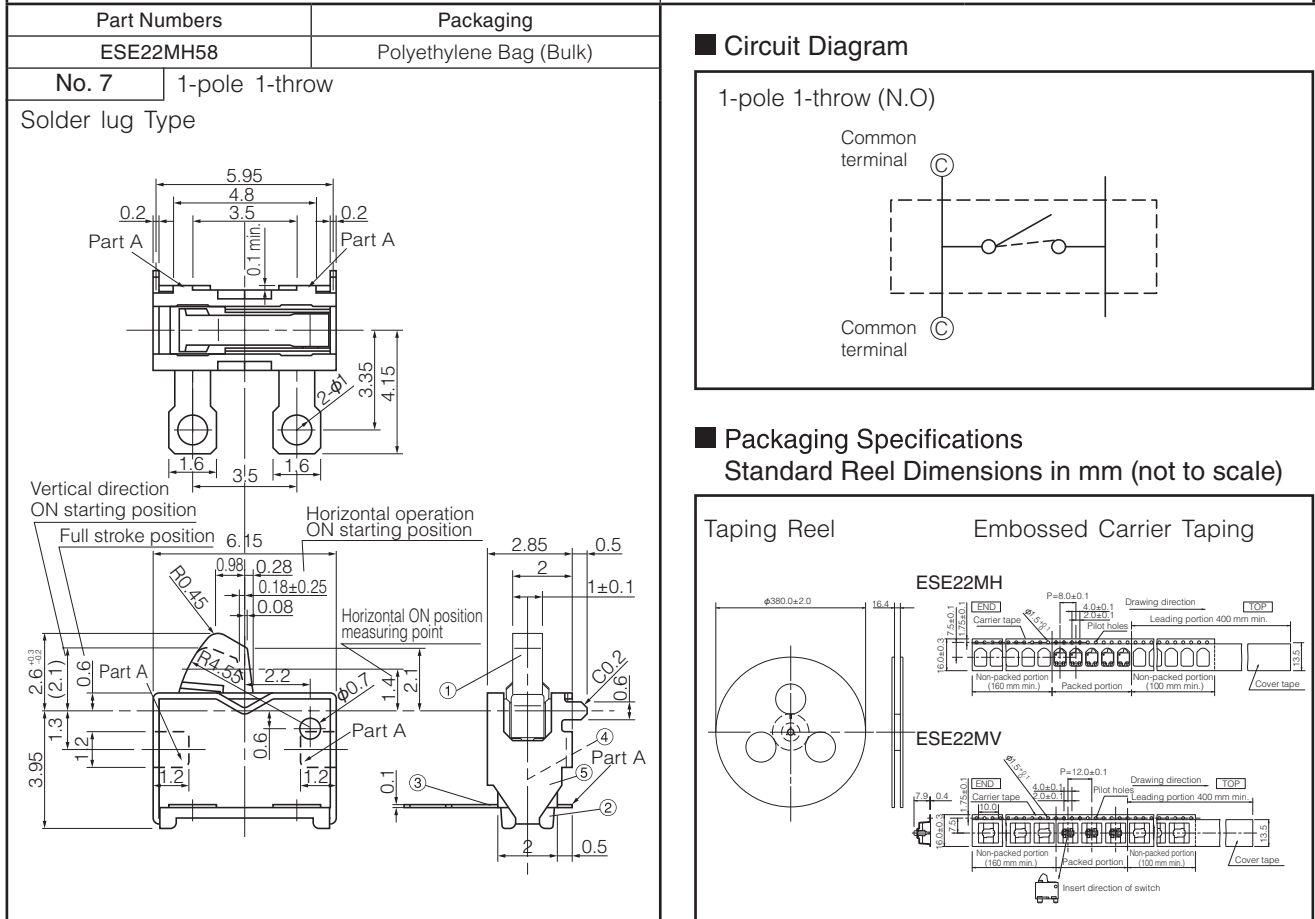
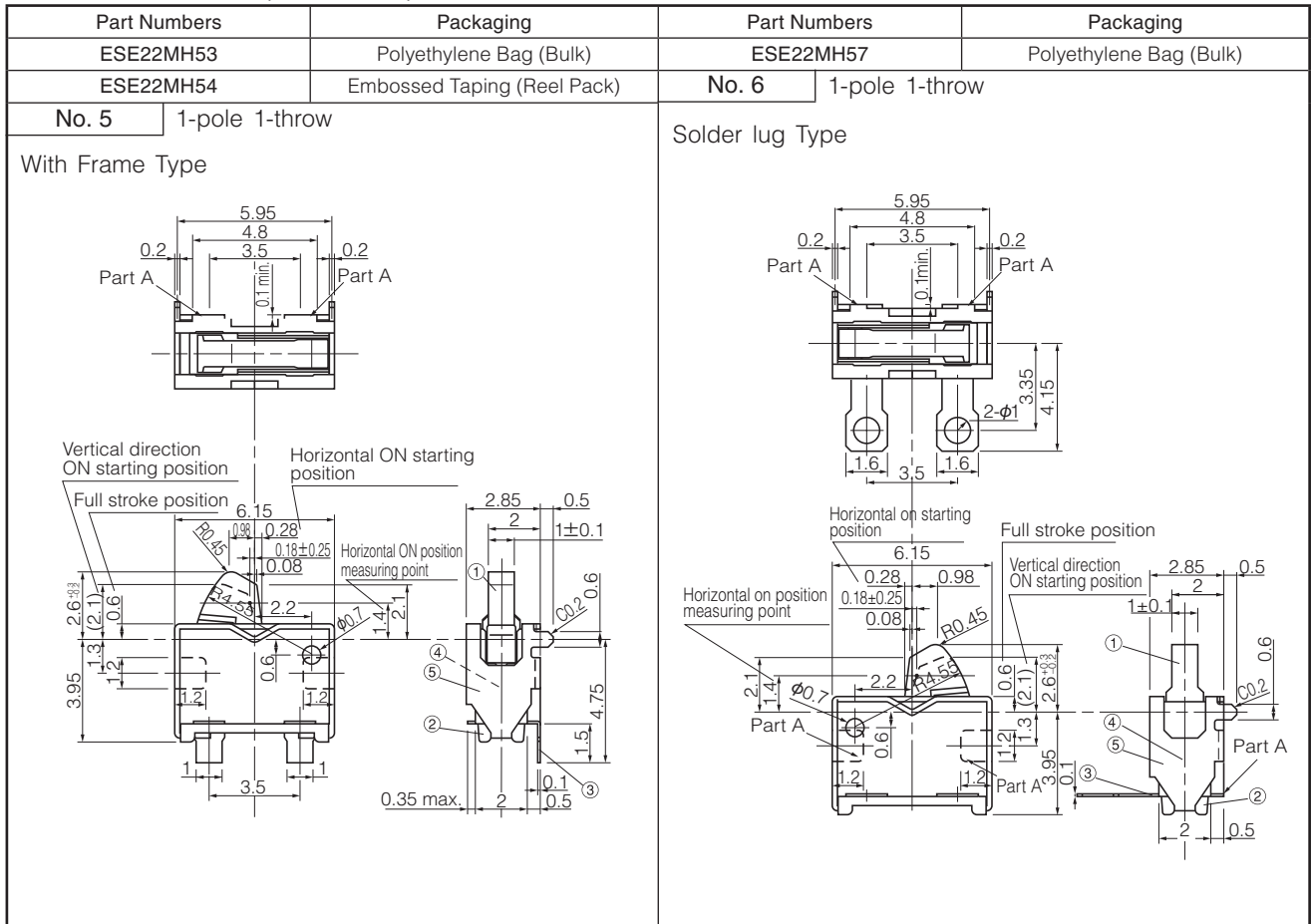

Design and specifications are each subject to change without notice. Ask factory for the current technical specifications before purchase and/or use.
Should a safety concern arise regarding this product, please be sure to contact us immediately.