



Chipsmall Limited consists of a professional team with an average of over 10 year of expertise in the distribution of electronic components. Based in Hongkong, we have already established firm and mutual-benefit business relationships with customers from,Europe,America and south Asia,supplying obsolete and hard-to-find components to meet their specific needs.

With the principle of “Quality Parts,Customers Priority,Honest Operation,and Considerate Service”,our business mainly focus on the distribution of electronic components. Line cards we deal with include Microchip,ALPS,ROHM,Xilinx,Pulse,ON,Everlight and Freescale. Main products comprise IC,Modules,Potentiometer,IC Socket,Relay,Connector.Our parts cover such applications as commercial,industrial, and automotives areas.

We are looking forward to setting up business relationship with you and hope to provide you with the best service and solution. Let us make a better world for our industry!



## Contact us

Tel: +86-755-8981 8866 Fax: +86-755-8427 6832

Email & Skype: info@chipsmall.com Web: www.chipsmall.com

Address: A1208, Overseas Decoration Building, #122 Zhenhua RD., Futian, Shenzhen, China





# ESP-125-T

## Quartz Restrike System

**Intelligent Device**  
**ECOSYSTEM**  
Classic

### Features

The ESP-125-T is a traditional 120V control that incorporates a current sense circuit that automatically lights a quartz lamp when the main HID lamp is extinguished. It has a built-in timer to keep the quartz lamp on for 2-3 minutes during the HID lamp warm-up period.

- For use with HPS or Metal Halide (probe-start or pulse start) magnetic ballasts with a 120V tap or input
- 50/60 Hz Operation
- Compact and simple to wire
- Measures the current drawn by the HID circuit rather than voltage across the circuit allowing use with virtually any type of lamp or ballast circuit
- Operates on HID circuits from 39-1500 watts
- Operates auxiliary lamps up to 500W
- Non-arcing switches allow the ESP-125-T to be used in Class 1, Division II vapor tight fixtures
- Can be wired directly to emergency generator power
- High temperature, flameproof plastic enclosure, 105°C maximum surface temp rating
- Timed Version (-T) keeps Quartz Lamp illuminated for 2-3 minutes until HID lamp reaches 25-50% brightness
- Patent Pending
- Not for use with F-can ballasts with ignitors



### Dimensions

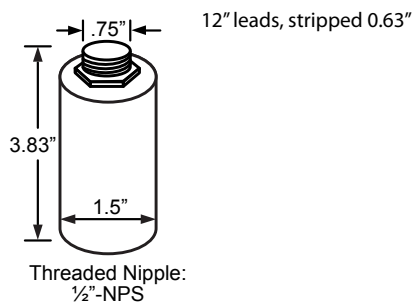

### Wiring

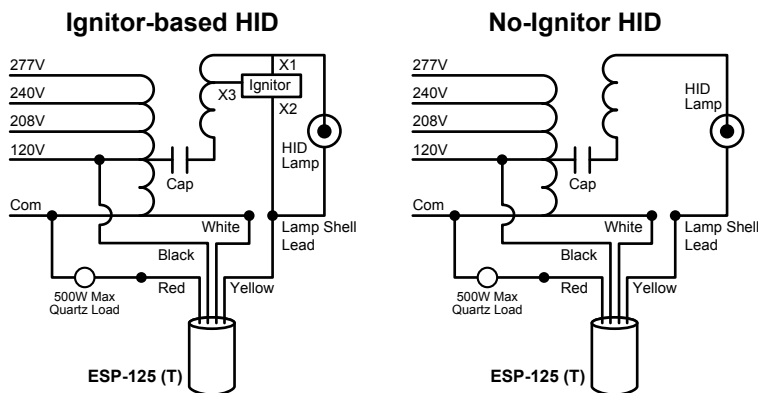

★ **MADE IN USA** ★  
Of Imported And Domestic Components

