



Chipsmall Limited consists of a professional team with an average of over 10 year of expertise in the distribution of electronic components. Based in Hongkong, we have already established firm and mutual-benefit business relationships with customers from,Europe,America and south Asia,supplying obsolete and hard-to-find components to meet their specific needs.

With the principle of “Quality Parts,Customers Priority,Honest Operation,and Considerate Service”,our business mainly focus on the distribution of electronic components. Line cards we deal with include Microchip,ALPS,ROHM,Xilinx,Pulse,ON,Everlight and Freescale. Main products comprise IC,Modules,Potentiometer,IC Socket,Relay,Connector.Our parts cover such applications as commercial,industrial, and automotives areas.

We are looking forward to setting up business relationship with you and hope to provide you with the best service and solution. Let us make a better world for our industry!



Contact us

Tel: +86-755-8981 8866 Fax: +86-755-8427 6832

Email & Skype: info@chipsmall.com Web: www.chipsmall.com

Address: A1208, Overseas Decoration Building, #122 Zhenhua RD., Futian, Shenzhen, China





ESP-AUTO-T

Universal Voltage Quartz Restrike System

Intelligent Device
ECOSYSTEM
Classic

Features

The ESP-AUTO-T is a universal voltage (120-277V) control that incorporates a current sense circuit that automatically lights a quartz lamp when the main HID lamp is extinguished. It has a built-in timer to keep the quartz lamp on for 2-3 minutes during the HID lamp warm-up period.

- For or electronic ballast from 120V-277V Universal Voltage Input (Not for use with magnetic ballasts)
- Compact and simple to wire
- Measures the current drawn by the HID lamp circuit rather than output voltage across the circuit allowing use with virtually any type of lamp or ballast circuit
- Operates on HID circuits from 39-450 watts
- Operates auxiliary lamps up to 250W
- High temperature, flameproof plastic enclosure, 90°C maximum surface temp rating
- Non-arcing switches allow the ESP-AUTO-T to be used in Class 1, Division II vapor tight fixtures
- Can be wired directly to emergency generator power
- Timed Version (-T) keeps Quartz Lamp illuminated for 2-3 minutes until HID lamp reaches 25-50% brightness
- Not to be used to drive a Fluorescent standby source, use ASP-AUTO-T for that application
- Patents Pending
- Quartz lamp is operated @ 120V for any line-voltage input; 120 through 277V



Dimensions

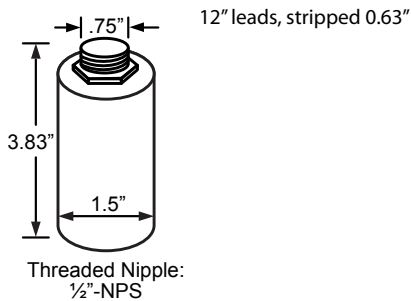

Wiring

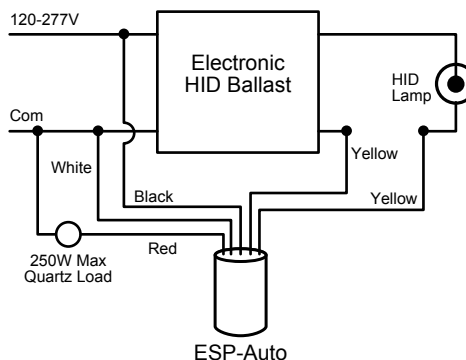

★ **MADE IN USA** ★
Of Imported And Domestic Components

